

DAIKIN



DAIKIN

Marine type

Container Refrigeration Unit

Service Manual

DAIKIN CONTAINER

LXE10E-1

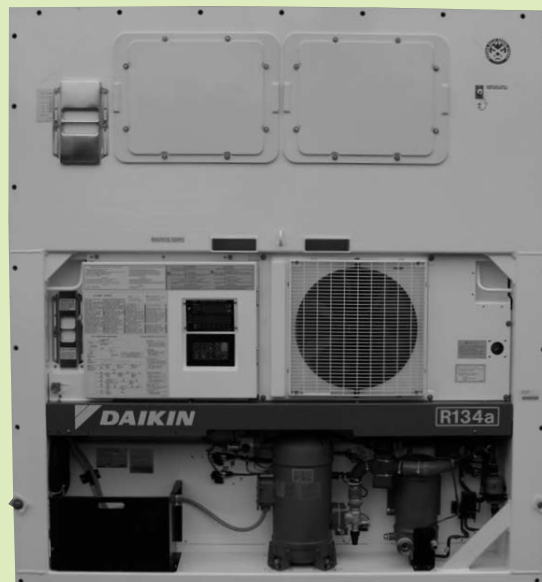

DAIKIN INDUSTRIES, LTD.

TR 03-06

<https://daikin-p.ru>

Please read the contents of this manual prior to operation of the unit.

In addition, refer to the manuals listed below:

- Parts List
- Operation Manual of Personal Computer Software

CONTENTS

Safety Precautions	
• Danger	3
• Warning	4
• Caution	5
1. Introduction	1-1
1.1 Operation range	1-1
1.2 Basic Names of components	1-1
1.3 Basic operation of refrigeration unit	1-2
1.3.1 Operation preparation	1-2
1.3.2 Starting operation	1-3
1.3.3 Checking during operation	1-4
1.3.4 Procedure after operation	1-4
1.3.5 Adjust the ventilation	1-5
2. General description	2-1
2.1 Main specifications	2-1
2.2 Names of components	2-2
2.2.1 Outside	2-2
2.2.2 Inside	2-4
2.2.3 Control box	2-6
2.3 Set point of functional parts and protection devices	2-9
2.4 Operating pressure and running current	2-10
2.5 Operation modes and control	2-14
2.5.1 Frozen mode	2-15
2.5.2 Chilled mode	2-17
2.5.3 Defrosting mode	2-19
2.5.4 Dehumidification	2-22
2.5.5 Common control	2-23
3. Electronic Controller	3-1
3.1 Function table	3-1
3.2 Basic operation of electronic controller	3-3
3.2.1 Control panel	3-3
3.2.2 Operation mode and control	3-5
3.3 Operation procedure	3-6
3.3.1 Operation procedure flow chart	3-6
3.3.2 Mode operation procedure	3-9
1. Current indication mode	3-9
2. Operation setting mode	3-10
3. Battery mode	3-11
4. Mode operation	3-12
5. LED display light-OFF mode	3-15
6. Sensor indication mode	3-16
7. Temperature record scroll mode	3-19
8. Alarm record scroll mode	3-22
3.3.3 Setting flow chart	3-24
10. Optional function setting mode	3-26
11. Basic function setting mode	3-27
12. Optional condition setting mode	3-29
13. Input data mode	3-31
14. Controller software download mode	3-32
3.4 Alarm display and back-up function	3-33
3.4.1 Alarm list	3-33
3.4.2 Back-up operation at sensor malfunction	3-34
3.5 Battery	3-36
3.5.1 Specifications	3-36
3.5.2 Function	3-36
3.5.3 Battery check	3-36
3.5.4 Battery replacement (Rechargeable battery)	3-37
3.6 Information interchange with personal computer	3-38
3.6.1 Data logging	3-39
3.6.2 Software configuration	3-40
3.7 Inspection procedure for the electronic controller	3-42
3.8 Controller replacement and initial setting	3-43
3.8.1 Controller replacement	3-43
3.8.2 Initial setting & operation procedure	3-44
3.9 PTI (Pre-Trip Inspection) and periodic inspection	3-45
3.9.1 Inspection item	3-46
3.9.2 Automatic PTI (Pre-Trip Inspection)	3-49
3.9.2.1 PTI selection mode	3-50
3.9.2.2 Short PTI (S.PTI)	3-51
3.9.2.3 Full PTI (F.PTI)	3-52
3.9.2.4 Alarm list during PTI (Pre-Trip Inspection)	3-54
3.9.2.5 Manual check (M.CHECK)	3-55
3.10 Chartless function	3-57
3.10.1 Chart indication mode	3-57
3.10.2 P code (Pull down time indication)	3-59
3.10.3 Chartless code display function	3-60
3.10.3.1 List of chartless codes	3-60
3.10.3.2 H-code	3-61
3.10.3.3 d-code:	3-63
3.11 Communication modem	3-64
4. Service and Maintenance	4-1
4.1 Maintenance service	4-1
4.1.1 Collection of refrigerant	4-1
4.1.2 Gauge manifold	4-1
4.1.3 Automatic pump down	4-3
4.1.4 Refrigerant recovery and charge	4-5
4.2 Main components and maintenance	4-9
4.2.1 Scroll compressor	4-9
4.2.2 Fan and fan motor	4-15
4.2.3 PT and CT board (EC9756)	4-16
4.2.4 Electronic expansion valve	4-17
4.2.5 Thermostatic expansion valve	4-18
4.2.6 Suction modulation valve	4-19
4.2.7 Drier	4-20
4.2.8 Solenoid valve	4-21
4.2.9 Discharge pressure regulating valve	4-22
4.2.10 Check valve	4-22
4.2.11 High-pressure switch (HPS)	4-23
4.2.12 Low pressure transducer (LPT)	4-23
4.2.13 High pressure transducer (HPT)	4-24
4.2.14 Water pressure switch (WPS)	4-24
4.2.15 Humidity sensor	4-24
4.2.16 Ventilation port opening degree sensor (FA sensor)	4-25
4.2.17 Air-cooled condenser and evaporator	4-25
4.2.18 Water cooled condenser	4-26
4.2.19 Fusible plug	4-26
4.2.20 Liquid/moisture indicator	4-26
4.2.21 Evacuation and dehydrating	4-27
5. Additional Devices	5-1
5.1 USDA transportation	5-1
5.1.1 Type of USDA sensor/receptacle	5-1
5.1.2 Initial setting	5-1
5.1.3 USDA sensor calibration	5-1
5.1.4 USDA transportation requirement	5-1
5.1.5 USDA report	5-1
6. Troubleshooting	6-1
6.1 Refrigeration system and electrical system	6-1
6.2 Alarm codes on electronic controller	6-5
6.3 Troubleshooting for automatic PTI (J-code)	6-10
6.4 Emergency operation	6-12
6.4.1 Emergency operation of controller	6-12
6.4.2 Short circuit operation of controller	6-13
6.4.3 Opening adjustment of electronic expansion valve	6-14
6.4.4 Emergency operation of suction modulating valve	6-15
6.4.5 Automatic Back up for supply / return air temperature sensors	6-16
7. Appendix	7-1
7.1 Standard tightening torques for bolts	7-1
7.2 Standard tightening torques for flare nuts	7-1
7.3 Standard tightening torque for stop valve	7-1
7.4 Resistance of motor coil and solenoid valve coil	7-2
7.5 Standard tightening torque for electronic expansion valve coil (EV coil)	7-2
7.6 HFC134a, temperature-vapor pressure characteristics table	7-3
7.7 Temperature sensor characteristics table	7-4
7.8 Temperature sensor characteristics table DCHS	7-5
7.9 High pressure transducer characteristics table	7-5
7.10 Low pressure transducer characteristics table	7-5
7.11 Piping diagram	7-6
7.12 Pilot lamps	7-7
7.13 Fuse protection table	7-8
7.14 Schematic wiring diagram	7-10
7.15 Stereoscopic wiring diagram	7-11

SAFETY PRECAUTIONS

Always observe the following points before operating or inspecting a unit.

DANGER

Always turn off the main power supply in the facility (※1) before disconnecting the power plug. 

Always turn off the main power supply in the facility (※1) before inspecting the interior of the control box. 

※ This is important because high voltage remains at the circuit breaker and the optionally provided modem even though the circuit breaker in the control box is turned off.

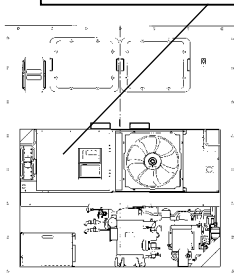
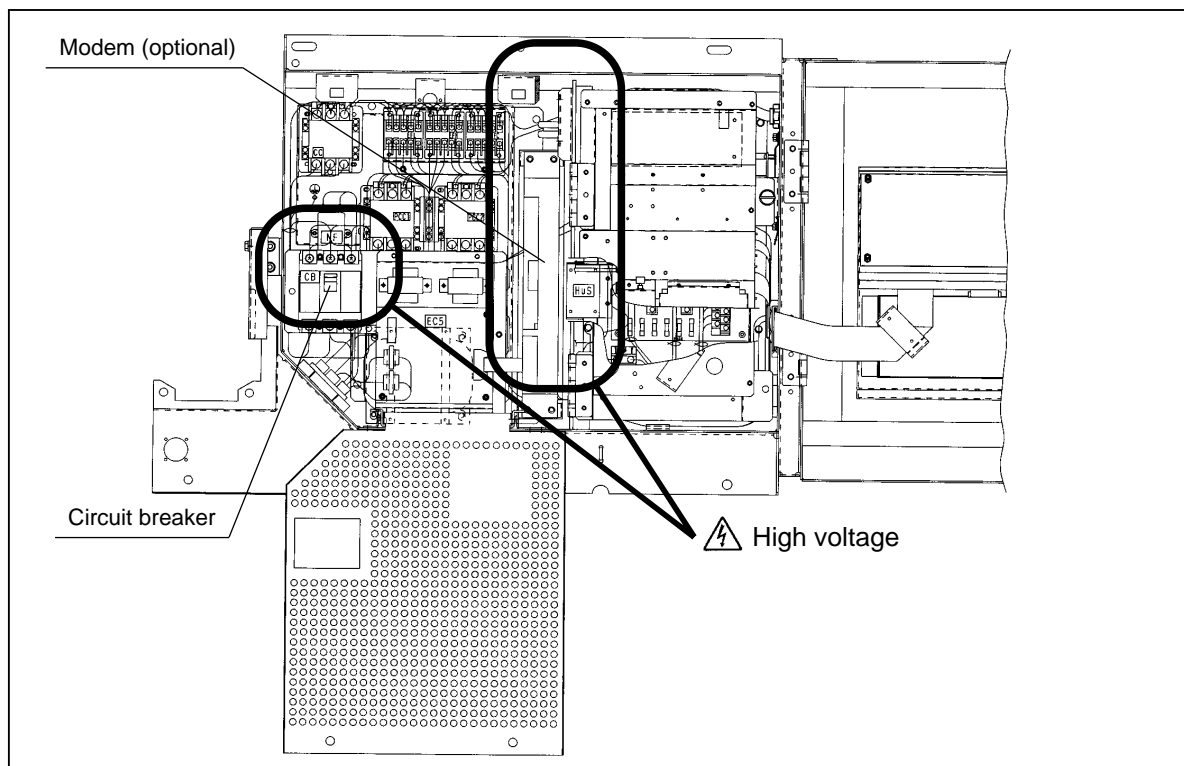

※1: with 30 Amps circuit breaker

 **WARNING**



Do not touch the condenser fan while power to the unit is ON.

Before removing the condenser fan cover, turn off the circuit breaker and disconnect the power plug.

During air-cooled operation : Condenser fan may start and stop automatically for the refrigerant high pressure control.

During water-cooled operation: Condenser fan may start and stop automatically for cooling of the control box.

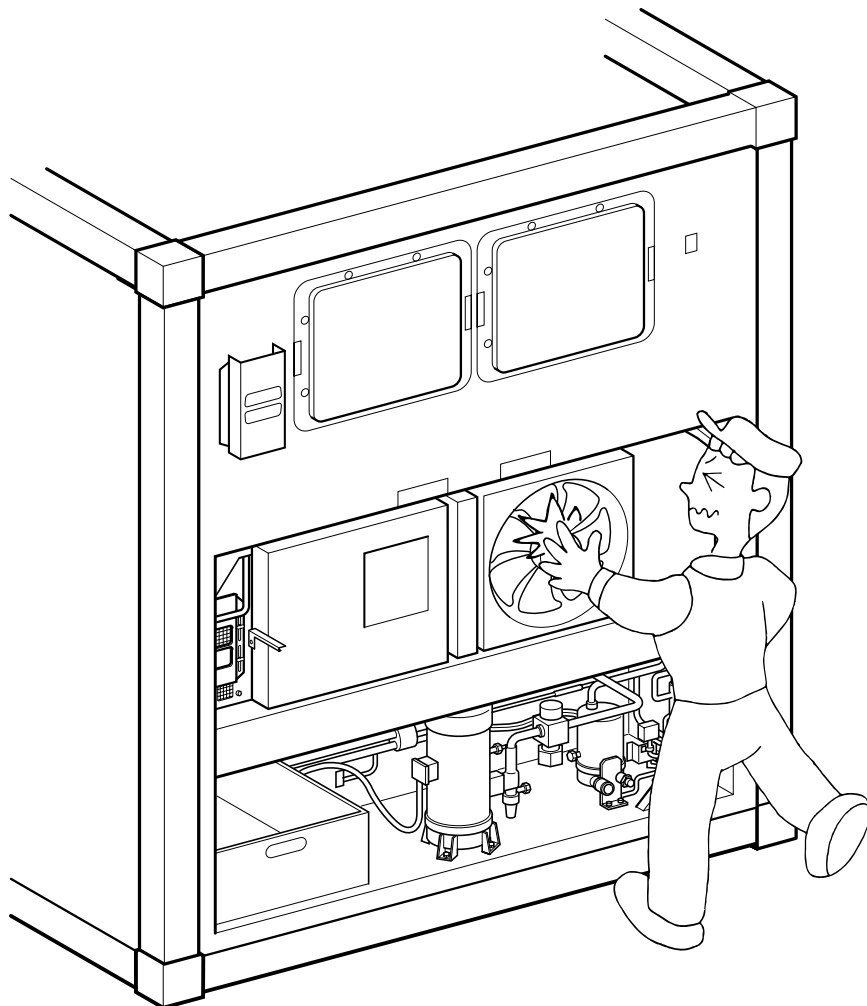

 **CAUTION**

Before starting the unit, run the generator.

Securely close the control box cover.
Otherwise, it will allow water entry.

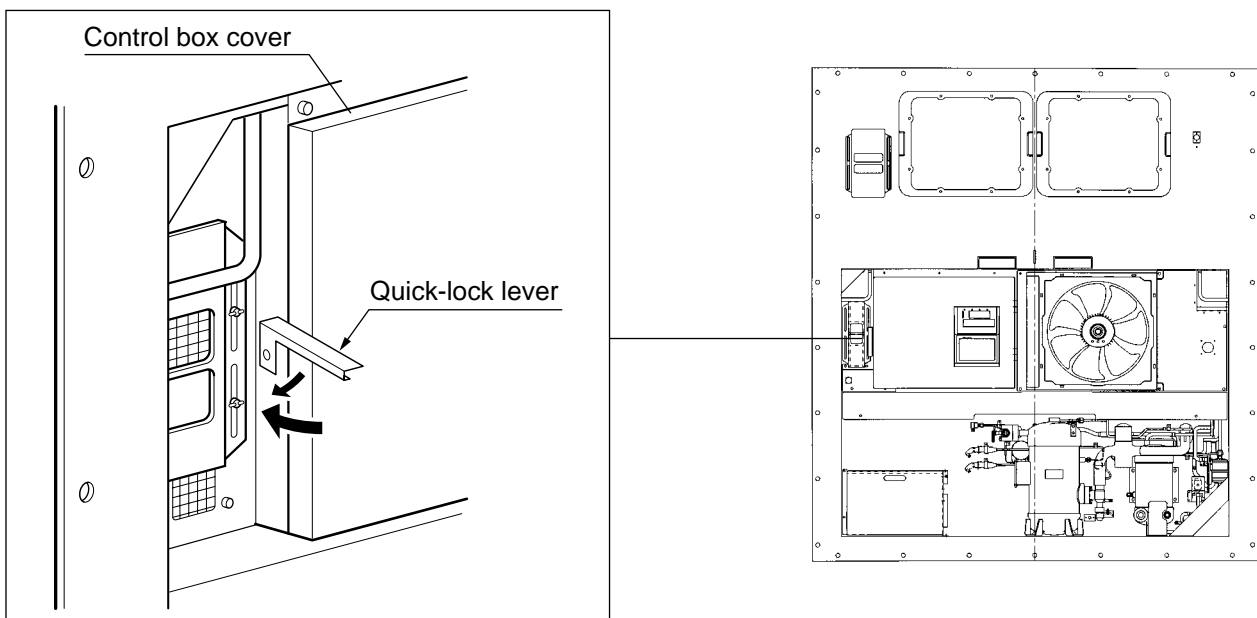

⚠ CAUTION

Wash the refrigeration unit with fresh water at PTI.

Carefully flush the air-cooled condenser with fresh water to remove the salt that sticks to it.

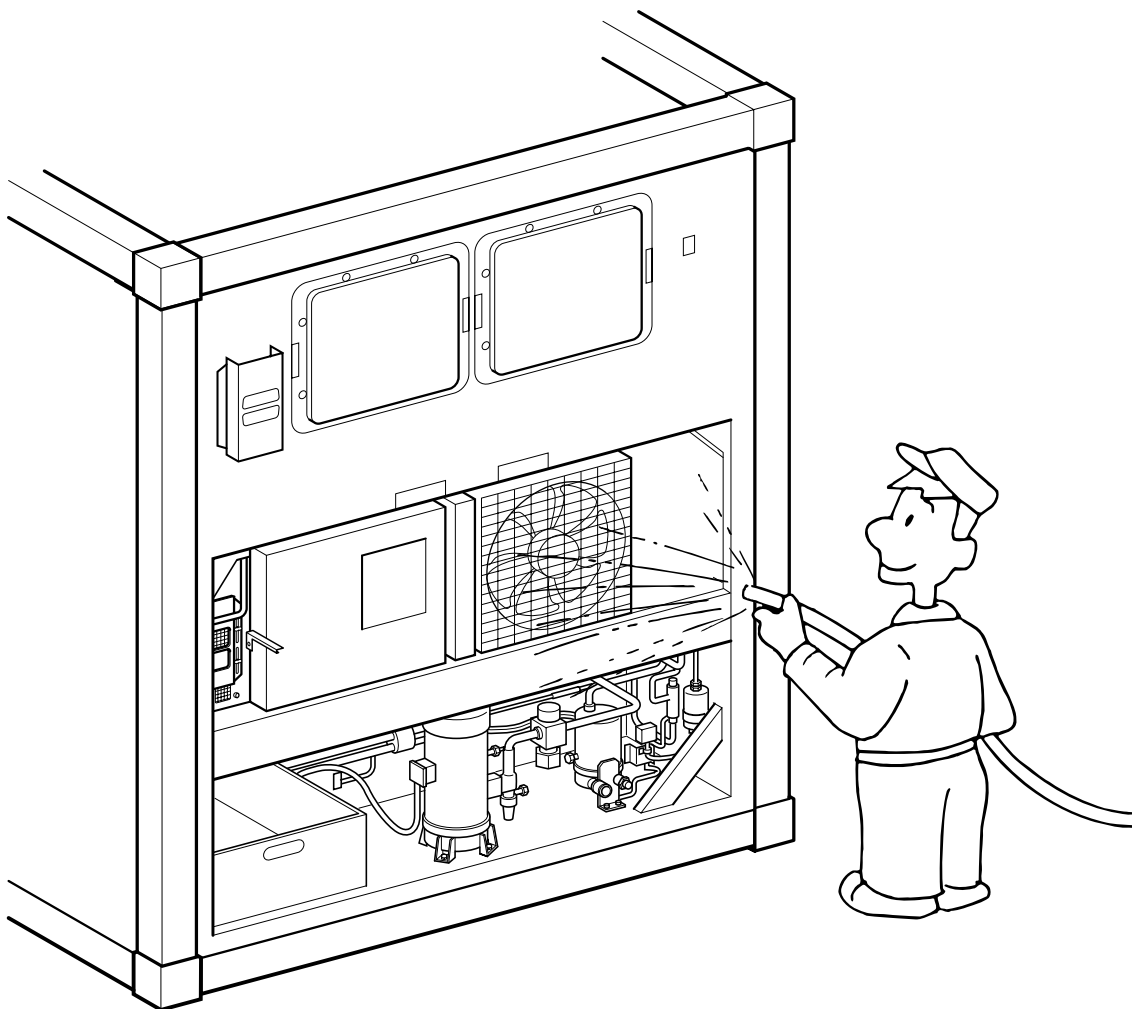

CAUTION

Refrigerant and refrigerant oil

Be sure to only charge the unit with refrigerant HFC 134a.
Never attempt to use any other refrigerant (CFC12, HCFC22, etc) with the refrigeration unit.
If any other refrigerant not specified is charged, it may cause problems with the unit.

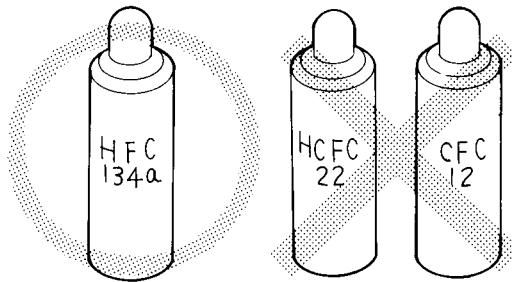

Use only Daikin specified oil (IDEMITSU, Daphne Hermetic Oil FVC46D) when replacing the refrigerant oil.
If any other refrigerating machine oil not specified is charged, it may cause problems with the unit.



Open the oil can, just before charging the oil, and use all the oil in the can once opened.
Do not leave the can open for 5 hours or longer to avoid moisture entry.
Using any refrigerant oil which has absorbed moisture may cause problems with the unit.

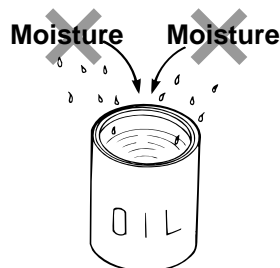

Use only exclusive tools for HFC134a. (gauge manifold, charging cylinder, etc)
Do not use any tools for CFC12 or HCFC22.
Service ports with exclusive quick joints for HFC134a are provided in the refrigeration unit to avoid improper refrigerant or refrigerant oil from entering into the refrigeration circuit. (Refer to section 4.4.2)
The charging hose and gauge port are not interchangeable with those of previous models using other refrigerants.

**CLASS 1 SPECIFIED PRODUCT BY
THE HYDROFLUORIC REFRIGERANT RECOVERY LAW**

HFC IS USED FOR THIS PRODUCT AS A REFRIGERANT.

- (1) EMISSION OF HYDROFLUORIC SUBSTANCES INTO THE ATMOSPHERE WITHOUT PERMISSION IS PROHIBITED.
- (2) RECOVERY OF HYDROFLUORIC SUBSTANCES IS MANDATORY WHEN SCRAPPING THIS PRODUCT.
- (3) THE KIND OF HYDROFLUORIC SUBSTANCE AND ITS AMOUNT ARE STATED IN THE MANUFACTURER'S LABEL OR THE ADDITIONALLY CHARGED AMOUNT LABEL.

1. Introduction

1.1 OPERATION RANGE

Use the units within the following range.

Item	Operation range	
Ambient temperature range	-30°C to +50°C (-22°F to + 122°F)	
Inside temperature range	-30°C to +30°C (-22°F to + 86°F)	
Cooling water	Temperature	10°C ~ 36°C (50°F ~ 96.8°F)
	Water volume	23 ~ 30ℓ/min.
	Pressure	196 ~ 490kPa (2 ~ 5kg/cm ²)
Voltage	50Hz: 380V/400V/415V, 60Hz: 440V/460V Voltage fluctuation rate should be within ±10%	
Vibration and shock	2G	

1.2 BASIC NAMES OF COMPONENTS

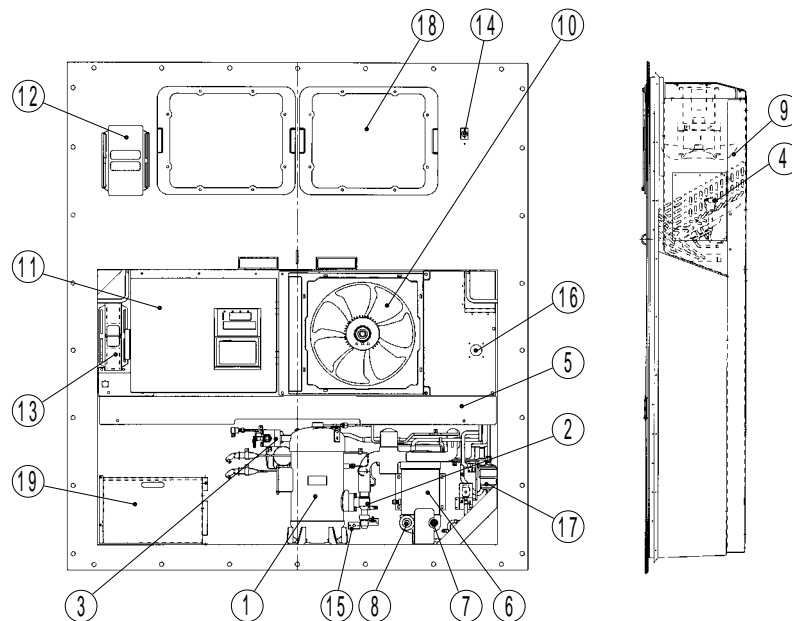

- | | |
|---|--|
| ① Compressor | ⑪ Control box |
| ② Compressor suction side stop valve | (Outside: switch, manual defrost switch, monitoring
receptacle
Inside: circuit breaker) |
| ③ Compressor discharge side stop valve | |
| ④ Evaporator | ⑫ Upper ventilator (Above 80m ³ /h) |
| ⑤ Air-cooled condenser | ⑬ Lower ventilator (Below 80m ³ /h) |
| ⑥ Water cooled condenser | ⑭ Sampling port (Return) (Use this port to measure the
inside return air temperature.) |
| ⑦ Cooling water inlet connector | ⑮ Gas sampling port (Supply) (This is used to measure the
inside supply air temperature
and inside CO ₂ concentration.) |
| (Connect these connector
when the water cooled
operation is required.
Operation will be changed to
water cooled operation
automatically) | ⑯ Liquid moisture indicator |
| | ⑧ Cooling water outlet connector |
| ⑨ Evaporator fan | ⑱ Access panel |
| ⑩ Condenser fan | ⑲ Storage space for power cable |

1.3 BASIC OPERATION OF REFRIGERATION UNIT

Operate the unit by the following procedure.

1.3.1 Operation preparation

(1) Make sure that the compressor discharge and suction side stop valves ①, ② are opened.

(Refer 1.2 Basic name of components.)

(2) Connect the cooling water piping to joints. (When the water cooled operation is required.)

Cooling water piping connection (Air and water cooled combination unit)

For water-cooled operation, connect the water piping to feed water.

■ Connection method

1. Connect the inlet joint ③.
2. Connect the outlet joint ④.

■ Disconnection method

1. Disconnect the outlet joint ④.
2. Disconnect the inlet joint ③.

Connect the cooling water joint in the following method.

Connection method: Insert a joint on the ship side in the piping joint on the unit side and push it in until you feel a click.

When connecting or disconnecting the joint, be careful not to be subject to cooling water splashes.

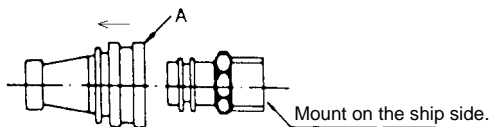

Piping connection method on cooling water outlet side

Disconnection method: Pull the joint on the ship side toward you with Part A of the joint on the female side pushed and held as shown by the arrow in figure above.



[Note] While in water-cooled operation, do not attempt to touch the condenser fan by hand. (The condenser fan turns ON or OFF to cool the control box.)

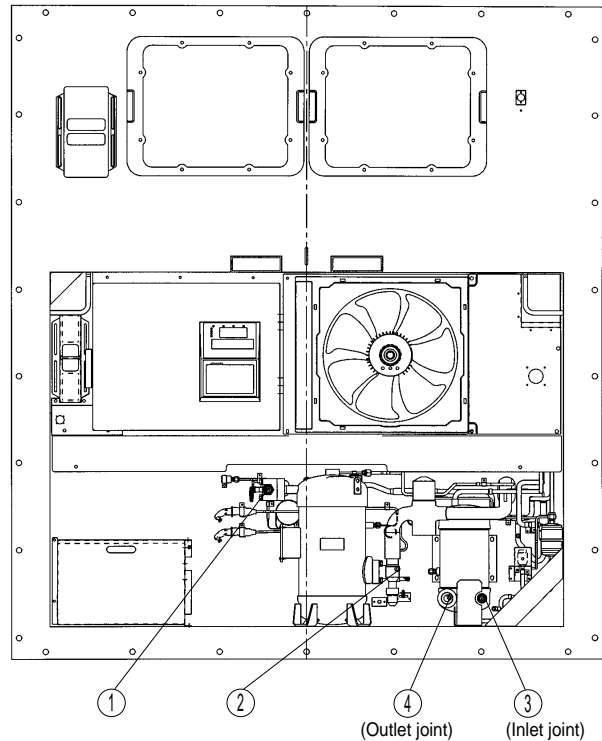

1.3.2 Starting operation

(1) Make sure that power to the unit is on.

(2) Connect the power plug to the power supply.

Insert the plug ⑤ suited to the power source voltage, and fasten the plug firmly.

(3) Turn on the main power switch of the power source facility (outside the unit)

(4) Turn on the circuit breaker ⑥.

(5) Close the control box cover fully.

If it is poorly closed, it will allow water entry. Check the contact around the packing, and firmly close the cover. (Refer to the "⚠ CAUTION " on page 5.)

(6) Press the UNIT ON/OFF key ⑦.

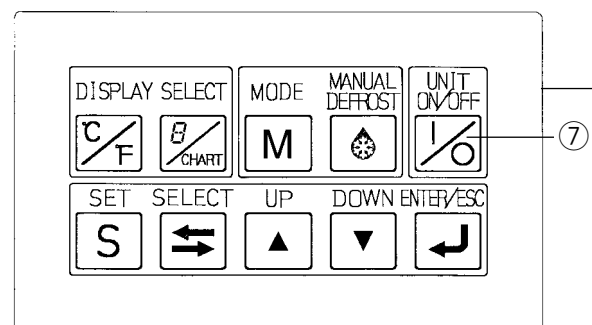
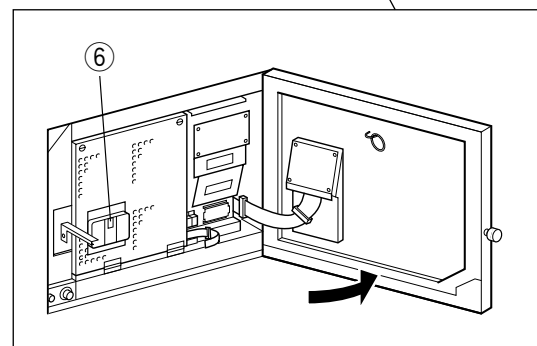
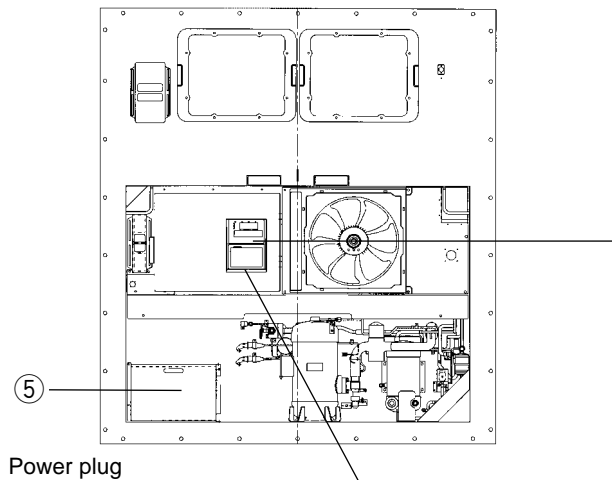

1.3.3 Checking during operation

Checking items(precautions)	Method of check
1. Check the compressor, fan, pipes, etc. for abnormal noise and vibration.	Visual and auditory
2. Check the refrigerant for shortage.	Visual During the chilled mode, the bubbles always appear in the moisture indicator. Do not charge the refrigerant excessively. Overcharging can damage the compressor.
3. Check the refrigerant for moisture inclusion.	Visual The moisture indicator colour; Green: normal Yellow: abnormal.
4. Check operating conditions with the pilot lamps.	Visual

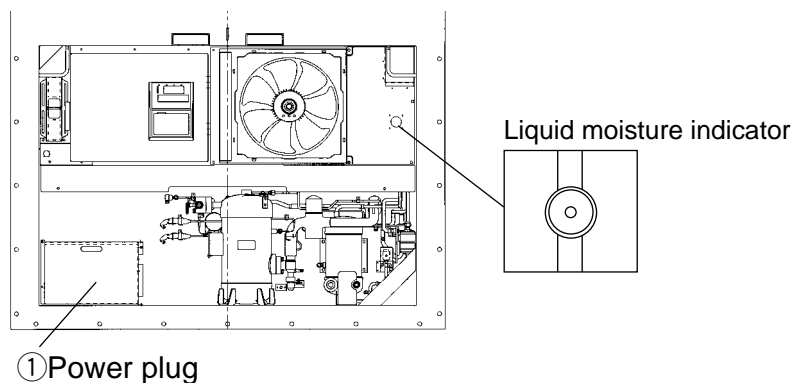

1.3.4 Procedure after operation

(1) Turn off the UNIT ON/OFF key ③, and turn off the circuit breaker ②.

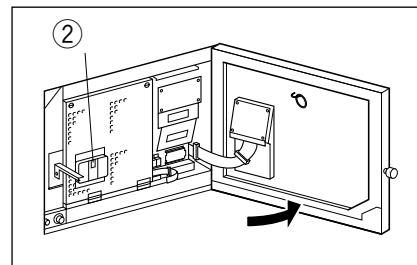

(2) Close the control box cover tightly.

(3) Stow the power cable.

Disconnect the power plug ①, and stow the power cable directing the plug opening downward to prevent sea water or rain water from collecting in the power plug.

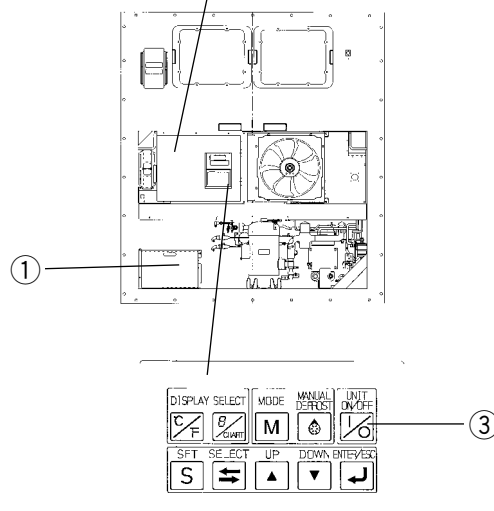

1.3.5 Adjust the ventilation

Adjust the opening of the lower or upper ventilator according to the cargo.
When the ventilation amount is 80 m³/h or more, use the upper ventilator to adjust the amount.
When the amount is not more than 80 m³/h, use the lower ventilator cover for the adjustment.



CAUTION

Keep the ventilation closed during transportation of the frozen cargo.

Upper ventilator (80~250m³/h)

When ventilation is not required (frozen mode), set the handle to "CLOSE".

When ventilation is required (chilled mode), slide the handle upward.

※ Set the arrow mark of the ventilation at the graduation on the scale to adjust the ventilation as desired according to the cargo.

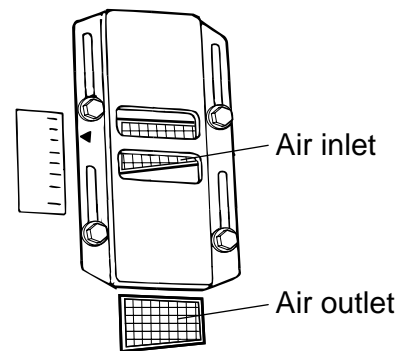
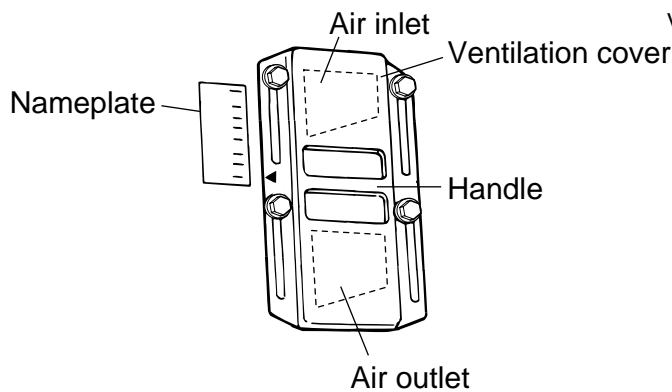

Lower ventilator (0~80m³/h)

When ventilation is not required (frozen mode), set the handle to "CLOSE".

When ventilation is required (chilled mode), slide the handle upward.

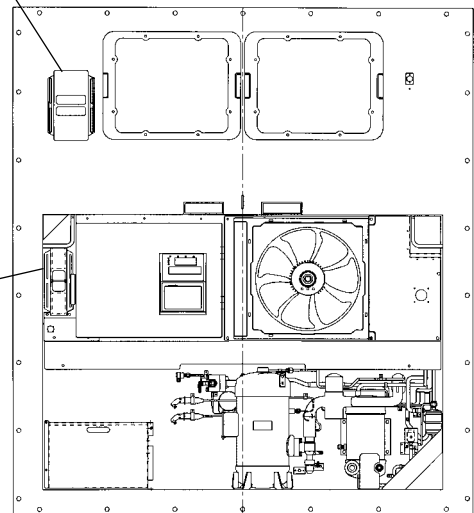
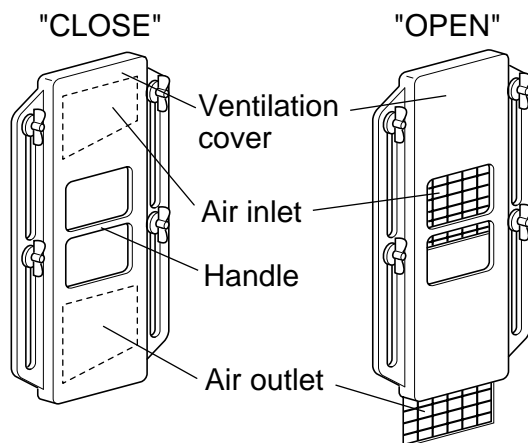

※ By pressing the  key on the operation panel, the ventilation amount will be displayed.

※ Caution for lower ventilator opening



CAUTION

Be sure to make the zero-point adjustment of the ventilation cover (if the ventilation amount is not more than 80 m³/h) at each PTI.

<Zero point adjustment procedure>

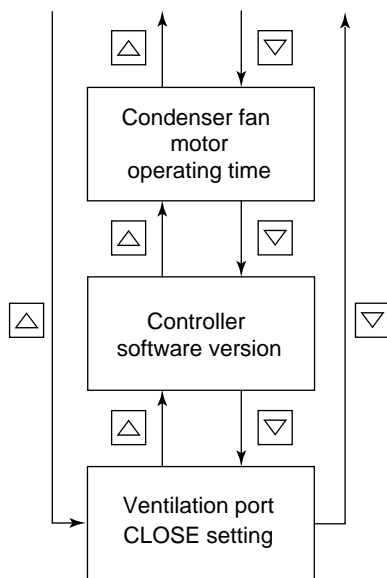
While the unit is running, move the ventilation port to a fully closed position manually to set the ventilation port to "closed state" (i.e., CLOSE setting mode), thus making automatic zero-point adjustment of ventilation amount through the difference from that at a position for the ventilation port to start port.



Use the  or  key while in manual check selection mode to set the ventilation port to CLOSE setting mode (in which the LCD screen displays "FA CAL". Then, press the  key, and the current value of sensor sliding amount will be displayed.

Pressing and holding the  key for a period of 3 seconds while the sliding amount is displayed will make it possible to reset the sliding amount to "0".

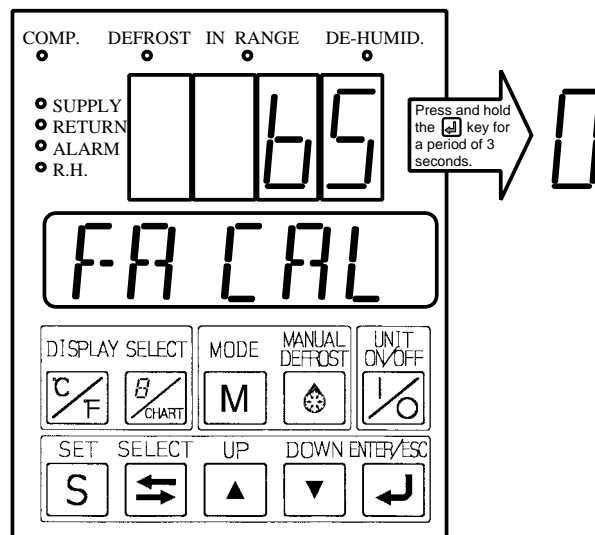

2. General description

2.1 Main specifications

Item	Model	LXE10E-1
Condenser cooling system		Air cooled type
Controller		DECOS III d
Power supply		AC 3-phase 380V/400V/415V 50Hz, 440V/460V 60Hz
Compressor		Hermetic scroll type (Motor output: 5.5kW)
Evaporator		Cross fin coil type
Air-cooled condenser		Cross fin coil type
Water-cooled condenser		Shell and coil type
Evaporator fan		Propeller fan
Evaporator fan motor		Three-phase squirrel-cage induction motor
Condenser fan		Propeller fan
Condenser fan motor		Three-phase squirrel-cage induction motor
Defrosting	System	Hot-gas defrosting system
	Initiation	Dual timer, on-demand defrost and manual switch
	Termination	Detecting the temperature of evaporator outlet pipe and return air
Refrigerant flow control		Electronic expansion valve
Capacity control		Capacity control with hot gas bypass and suction modulating valve
Protective devices /Safety devices		Circuit breaker, PT/CT board (for over current protection). Compressor thermal protector Condenser fan-motor thermal protector Evaporator fan-motor thermal protector High-pressure switch, Fusible plug, Fuse (10A, 5A)
Refrigerant (charged amount)		R134a : 5.4 (kg)
Refrigerant oil (charged amount)		IDEMITSU, Daphne hermetic oil FVC 46D : 2.2(ℓ)
Weight		LXE10E-1 : 505(kg)

2.2 Names of components

2.2.1 Outside

●LXE10E-1

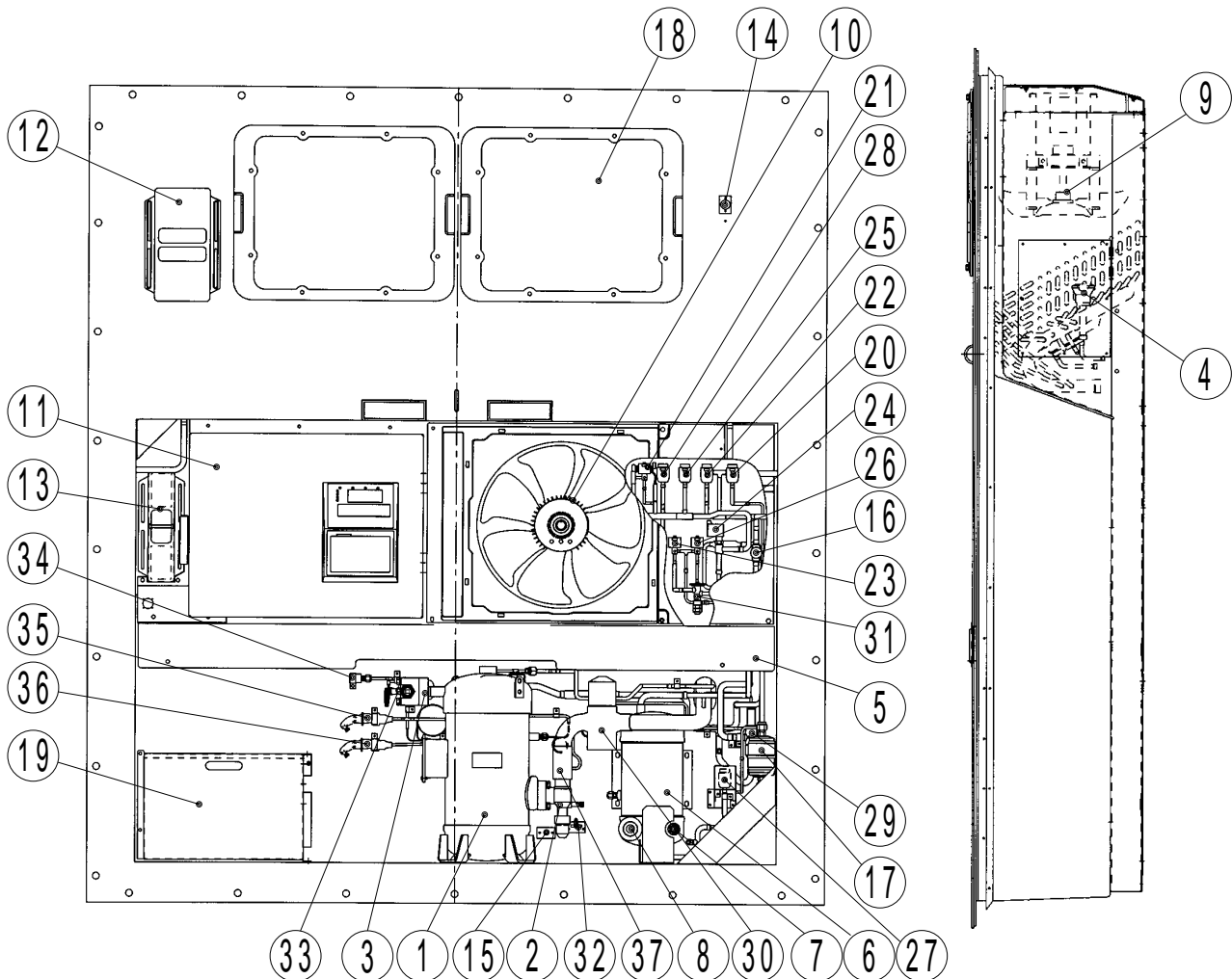

- | | |
|--|--|
| ① Compressor | ⑳ Discharge gas by-pass solenoid valve (BSV) |
| ② Compressor suction side stop valve | ㉑ Capillary solenoid valve (CSV) |
| ③ Compressor discharge side stop valve | ㉒ Defrost solenoid valve (DSV) |
| ④ Evaporator | ㉓ Economizer solenoid valve (ESV) |
| ⑤ Air-cooled condenser | ㉔ Electronic expansion valve (EV) |
| ⑥ Water cooled condenser | ㉕ Hot-gas solenoid valve (HSV) |
| ⑦ Cooling water inlet connector | ㉖ Injection solenoid valve (ISV) |
| ⑧ Cooling water outlet connector | ㉗ Liquid solenoid valve (LSV) |
| ⑨ Evaporator fan | ㉘ Reheat coil solenoid valve (RSV) |
| ⑩ Condenser fan | ㉙ Discharge pressure regulating valve (DPR) |
| ⑪ Control box | ㉚ Suction modulating valve (SMV) |
| ⑫ Upper ventilator (Above 80m ³ /h) | ㉛ Thermostatic expansion valve (TEV) |
| ⑬ Lower ventilator (Below 80m ³ /h) | ㉜ Ambient temperature sensor (AMBS) |
| ⑭ Sampling port (Return) | ㉝ Discharge pipe temperature sensor (DCHS) |
| ⑮ Gas sampling port Sampling port (Supply) | ㉞ High pressure switch (HPS) |
| ⑯ Liquid moisture indicator | ㉟ High pressure transducer (HPT) |
| ⑰ Drier | ㊱ Low pressure transducer (LPT) |
| ⑱ Access panel | ㊲ Compressor suction pipe temperature sensor (SGS) |
| ⑲ Storage space for power cable | |

●LXE10E-1

· Detail of solenoid valves

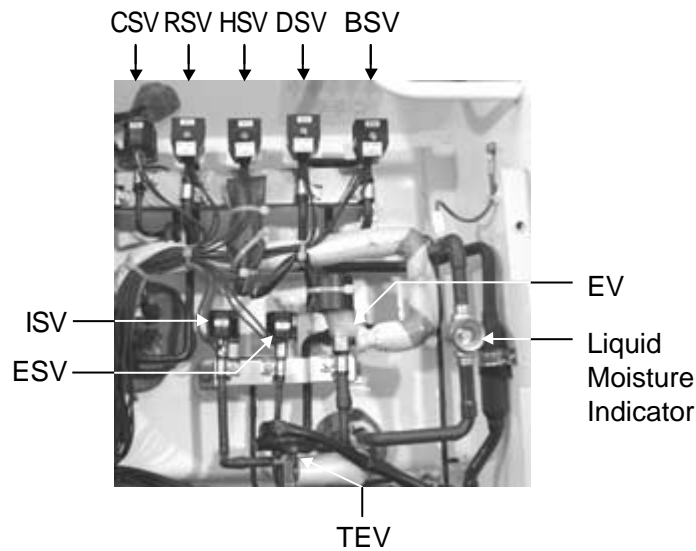

· Detail of compressor and refrigerant control devices

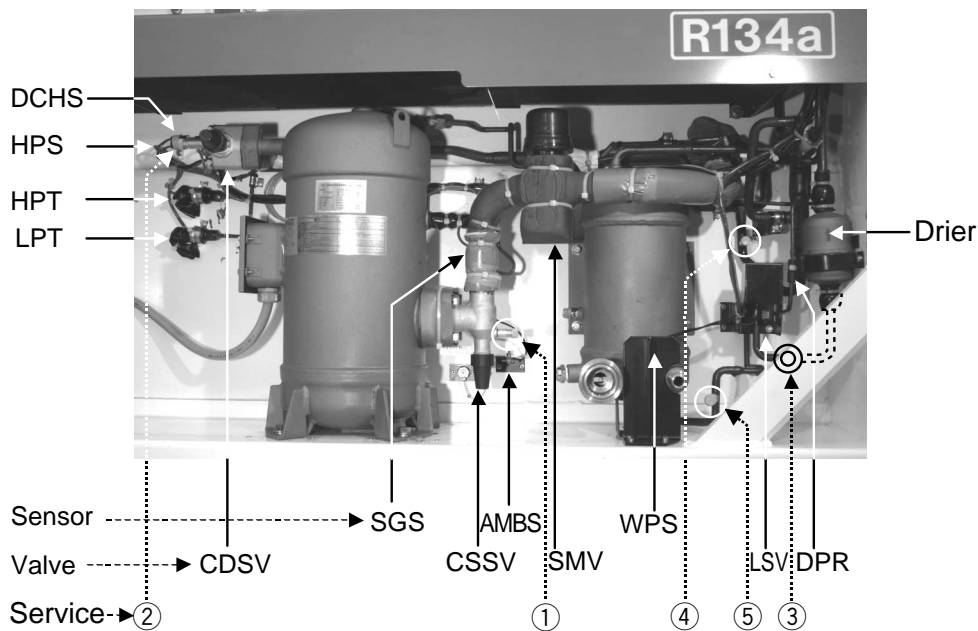

- [Valve]
- BSV :Bypass Solenoid Valve
 - CDSV:Compressor Discharge Stop Valve
 - CSSV:Compressor Suction Stop Valve
 - CSV :Capillary Solenoid Valve
 - DSV :Defrost Solenoid Valve
 - DPR :Discharge Pressure Regulator Valve
 - EV :Electronic Expansion Valve
 - ESV :Economizer Solenoid Valve
 - ISV :Injection Solenoid Valve
 - LSV :Liquid Solenoid Valve
 - RSV :Reheater Solenoid Valve
for dehumidification control
 - SMV :Suction Modulation Valve
 - TEV :Thermostatic Expansion Valve

- [Sensor]
- AMBS:Ambient Air Temperature Sensor
 - DCHS:Discharge Gas Temperature Sensor
 - HPS :High Pressure Switch
 - HPT :High Pressure Tranceducer
 - LPT :Low Pressure Tranceducer
 - SGS :Suction Pipe Temperature Sensor
 - WPS :Water Pressure Sensor

2.2.2 Inside

●LXE10E-1

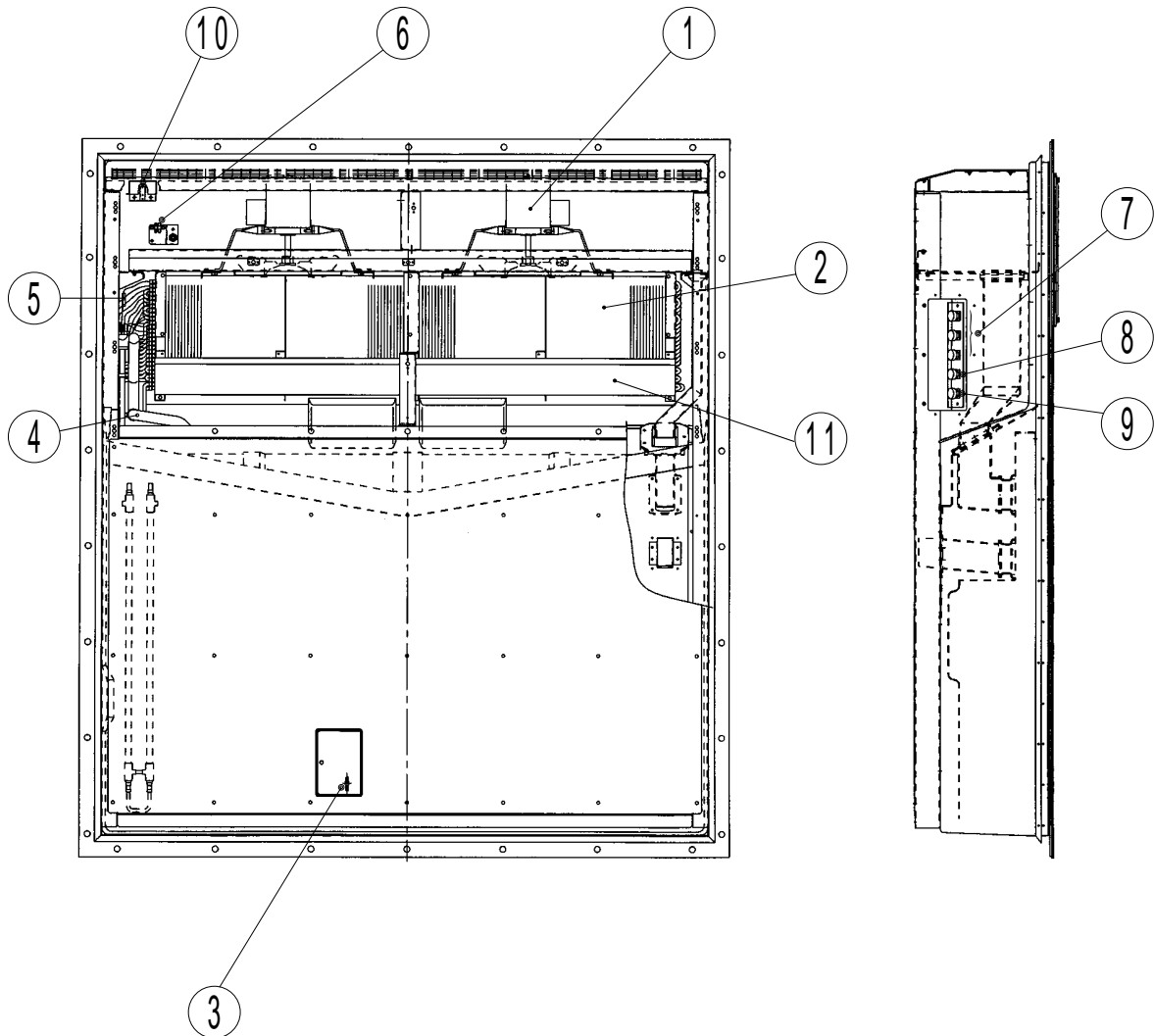

- ① Evaporator fan motor (EFM)
- ② Evaporator
- ③ Supply air temperature sensor (SS)
Data recorder supply air temperature sensor (DSS)
- ④ Evaporator outlet pipe temperature sensor (EOS)
- ⑤ Evaporator inlet pipe temperature sensor (EIS)
- ⑥ Return air temperature sensor (RS)
Data recorder return air temperature sensor (DRS, optional)
- ⑦ USDA receptacle
- ⑧ Cargo temp. receptacles
- ⑨ P.C. Port receptacles
- ⑩ Humidity sensor
- ⑪ Reheat coil

· Inside Detail

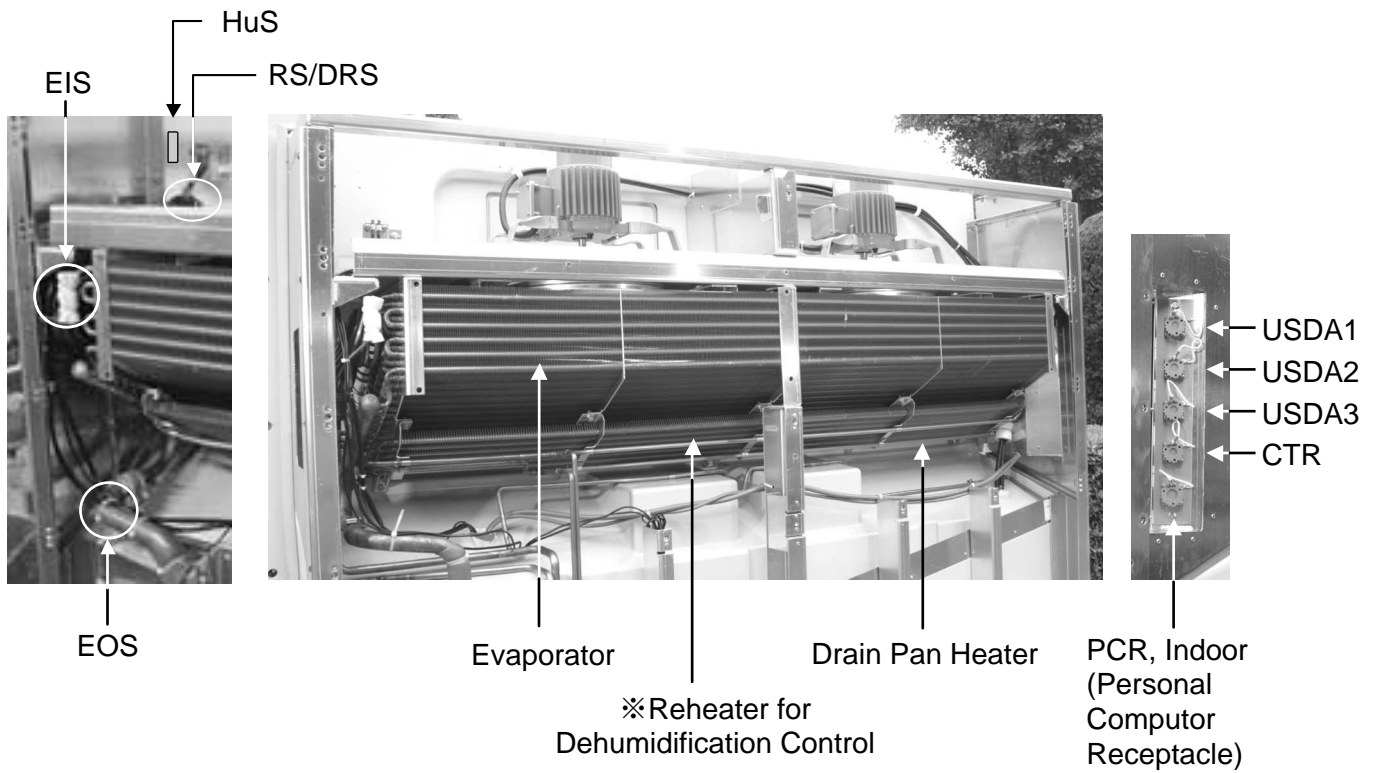

- [Sensor]
- CTR :Cargo Temperature Receptacle
 - DRS :Return Air Temperature Sensor for Datacorder
 - DSS :Supply Air Temperature Sensor for Datacorder
 - EIS :Evaporator Inlet Temperature Sensor
 - EOS :Evaporator Outlet Temperature Sensor
 - HuS :Humidity Sensor
 - RS :Return Air Temperature Sensor
 - SS :Supply Air Temperature Sensor
 - USDA 1:USDA Receptacle 1
 - USDA 2:USDA Receptacle 2
 - USDA 3:USDA Receptacle 3

2.2.3 Control box

● Inside of the control box

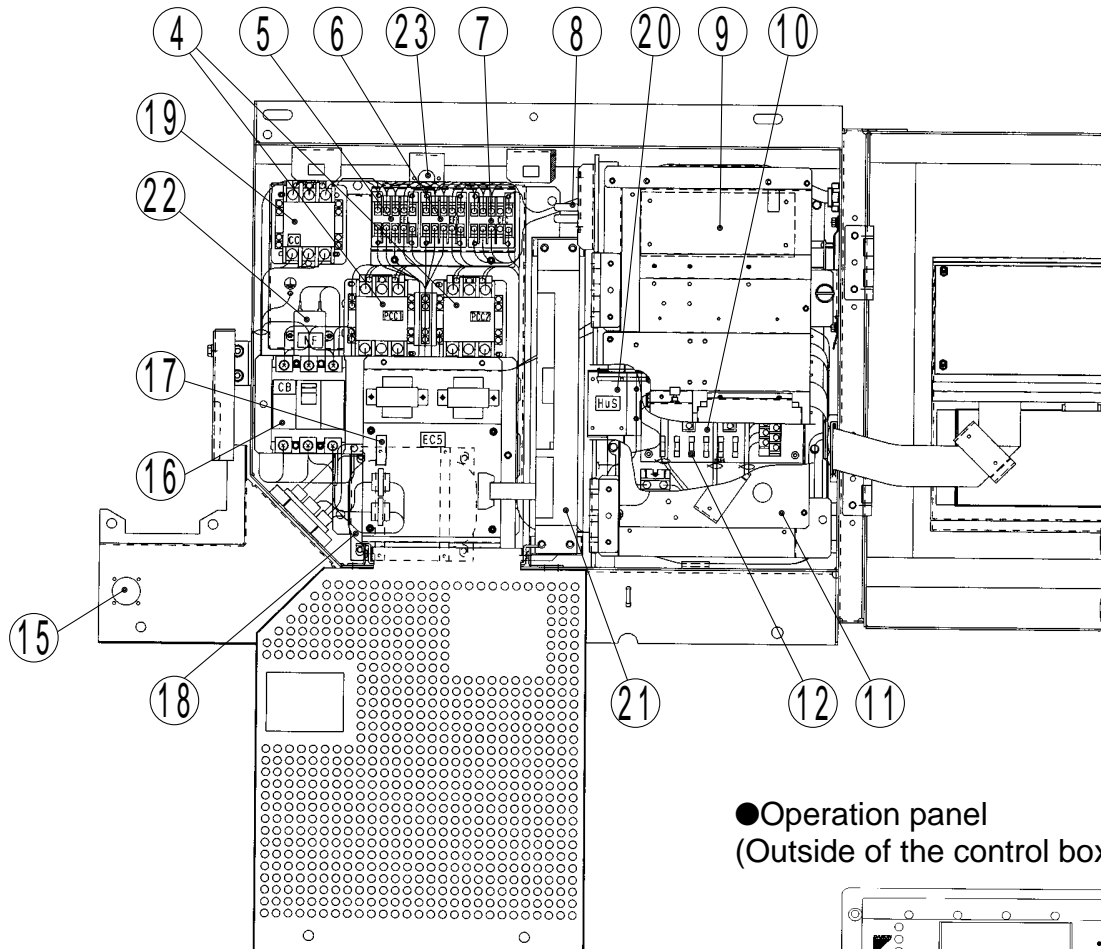

● Operation panel (Outside of the control box)

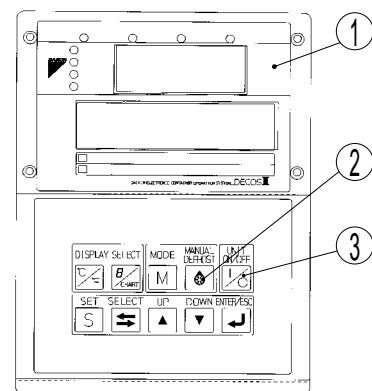

● Controller

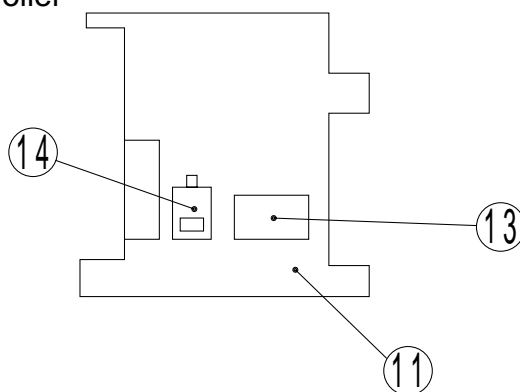

- | | |
|--|---|
| ① Controller operation panel (EC3, 4) | ⑬ Rechargeable battery (BAT) |
| ② MANUAL DEFROST key | ⑭ Voltage indicator |
| ③ UNIT ON/OFF key | ⑮ Personal computer receptacle |
| ④ Phase correction contactor (PCC1,2) | ⑯ Circuit breaker (CB) |
| ⑤ Magnetic contactor for low speed evaporator fan (EFL) | ⑰ PT/CT board |
| ⑥ Magnetic contactor for high speed evaporator fan (EFH) | ⑱ Transformer (TrC), control circuit |
| ⑦ Magnetic contactor condenser fan (CFC) | ⑲ Magnetic contactor for compressor (CC) |
| ⑧ Reverse phase protection device (RPP) | ⑳ P.C.B for humidity sensor (HUS, optional) |
| ⑨ Adopter PCB (EC6) | ㉑ Modem (RCD, optional) |
| ⑩ Terminal block board (TB1) | ㉒ Noise filter (NF, optional) |
| ⑪ Controller CPU / IO board (EC1, 2) | ㉓ Control box sensor (CBS) |
| ⑫ Fuse (Fu1-6) | |

- Control box Inside detail

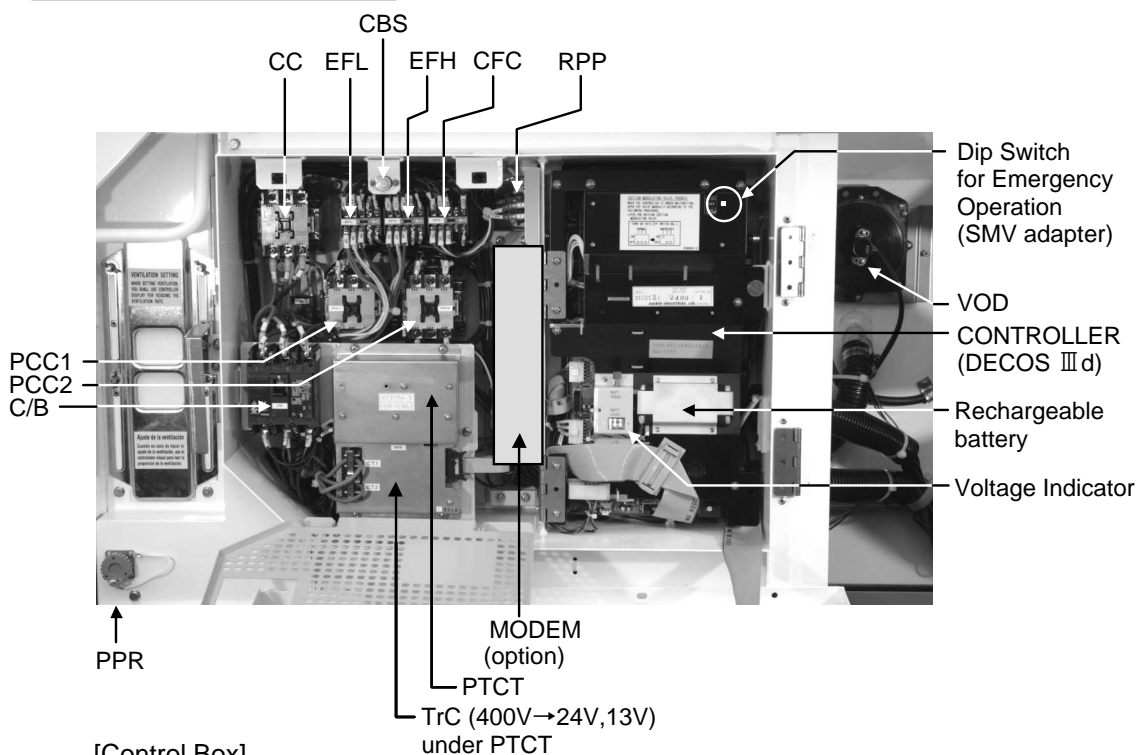

[Control Box]

- | | |
|---|-----------------------------------|
| CBS :Control Box Sensor | PCC1:Phase Correction Contactor 1 |
| CC :Magnetic Contactor, Compressor | PCC2:Phase Correction Contactor 2 |
| CFC :Magnetic Contactor, Condensor Fan Motor | PPR :PC Port Receptacle, Outdoor |
| C/B :Circuit Breaker | PTCT:PTCT Board |
| EFH :Magnetic Contactor, Evaporator Fan Motor, High Speed | RPP :Reverse Phase Protector |
| EFL :Magnetic Contactor, Evaporator Fan Motor, Low Speed | TrC :Transformer |
| | VOD :Ventilation Opening Detector |

- Controller Inside detail

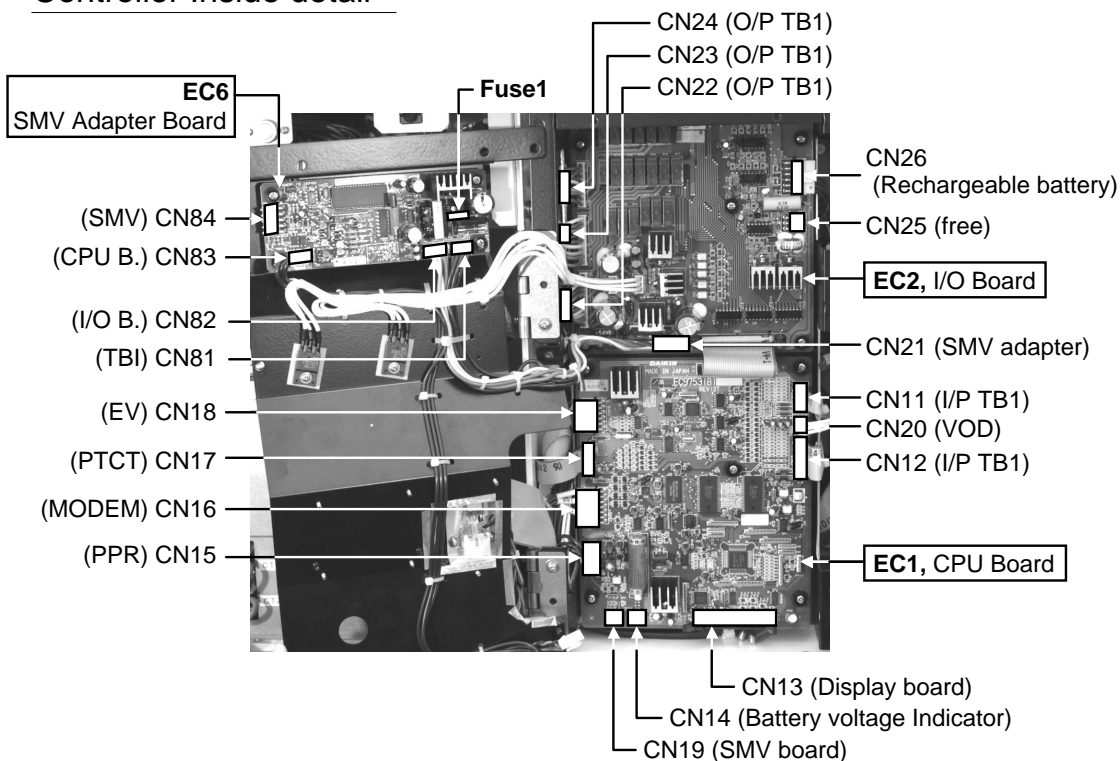

· Detail of terminal Board & Short circuit Connector

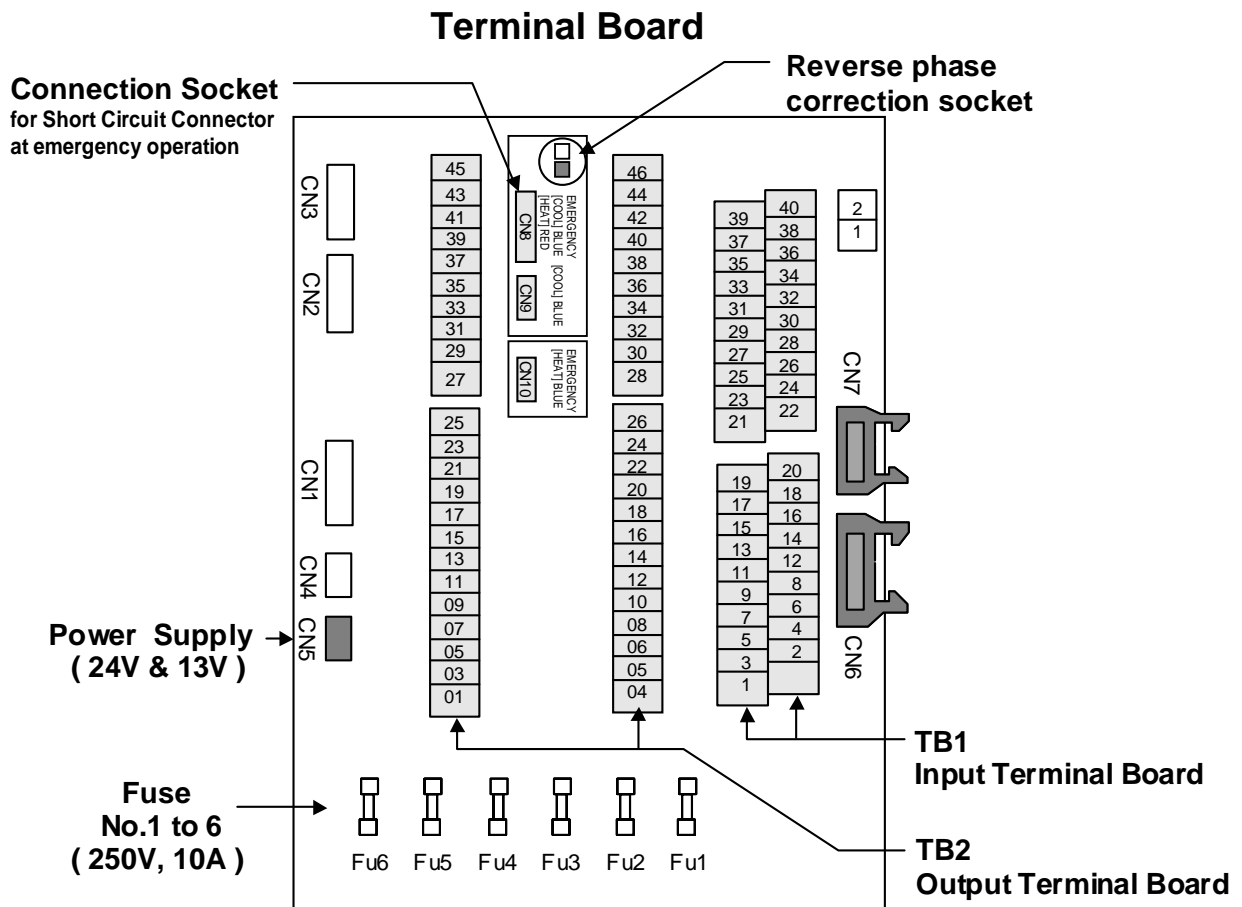
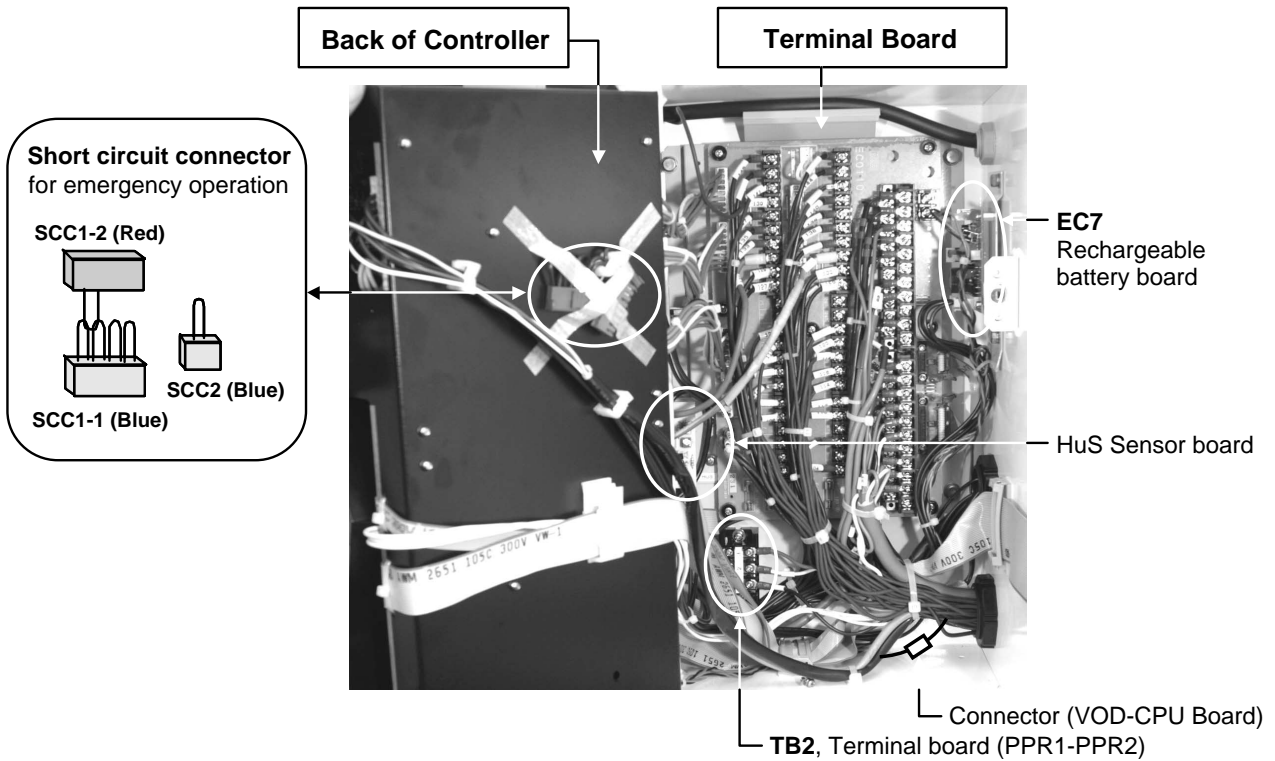

2.3 Set point of functional parts and protection devices

	Device name		Actuation	Set point	Detection method	Symbol	
Pressure switch	High-pressure switch		OFF ON	2400kPa (24.47kg/cm ²) 1900kPa (19.37kg/cm ²)	High-pressure switch	HPS	
	Water pressure switch		OFF ON	98kPa (1.0kg/cm ²) 39kPa (0.4kg/cm ²)	Water pressure switch	WPS	
Electronic controller	Mode selection	Chilled mode	ON	+30.0°C to -5.0°C (+86.0°F to -41.0°F)	Set point temperature	EC	
		Frozen mode		-5.1°C to -30.0°C (-41.2°F to -22.0°F)			
	Delay timer	Fan	Change-over for Hi/Lo	ON	10 seconds		
			After defrosting		60 seconds		
		Compressor	At starting		3 seconds		
	Defrosting timer	Initiation	Short	ON	4 hours ※1		
			Long		3, 6, 9, 12, 24 and 99 hours(※2)		
		Back-up		OFF	90 minutes		
		In-range masking		ON	90 minutes ※3		
		Out-range guard		ON	30 minutes		
	Defrosting termination set point		OFF Reset	30°C (86°F) 15°C (59°F) ※4	Evaporator outlet temperature sensor Return air temperature sensor	EOS RS, DRS	
	High-pressure control for Condenser fan (※Frozen only)		OFF ON	800kPa (8.2kg/cm ²) ※6 1000kPa (10.2kg/cm ²)	High-pressure transducer	HPT	
	Condenser fan ON/OFF setting value		OFF ON	49°C (120.2°F) 59°C (138.2°F)	Control box sensor	CBS	
	Discharge gas temperature protection set point	Pull down LPT>50kpa	OFF	135°C (275°F)	Discharge gas temperature sensor	DCHS	
			Reset	After 3 minutes elapsed			
LPT≤50kpa		OFF	128°C (262°F)				
Overcurrent protection set point (Cutout)		OFF Reset	26.0A After 3 minutes elapsed	PT/CT board	CT2		
Current control		Control	50Hz : 16.1A 60Hz : 17.4A	PT/CT board	CT1		
High pressure control		Control	2300 to 2350 kPa (23.5 to 24.0 kg/cm ²)	High pressure sensor	HPT		
Current	Circuit breaker		OFF	30A		CB	
	Fuse		OFF	5A, 10A ※5		Fu	
Motor	Evaporator fan motor thermal protector		OFF	132°C (270°F)			
	Condenser fan motor thermal protector		OFF	135°C (275°F)		MTP	
	Compressor motor thermal protector		OFF	140°C (284°F)		CTP	
—	Fusible plug		—	95~100°C			

(※1) When Return air (RS) is lower than -20°C, defrost starts every 6 hours.

(※2) When "99" hours is selected, refer to on demand defrost in 2.5.3.

(※3) When Inside set point is -20.0°C or Lower, In-range masking is 120min.

(※4) If defrost is initiated when inside temperature is out range area. (= In-range LED is not light), this condition is added to finish defrost. Refer to "Defrosting termination" in 2.5.3.

(※5) Refer to "Fuse Protection table" in 7.13.

(※6) When dehumidification is ON in dehumidification mode, the setting figure may change between 900~2100kPa automatically (Refer to "High Pressure Control" Page 2-24).

2.4 Operating pressure and running current

- Chilled mode
 Inside : 0°C (32°F)
 Power supply :
 415V / 50Hz

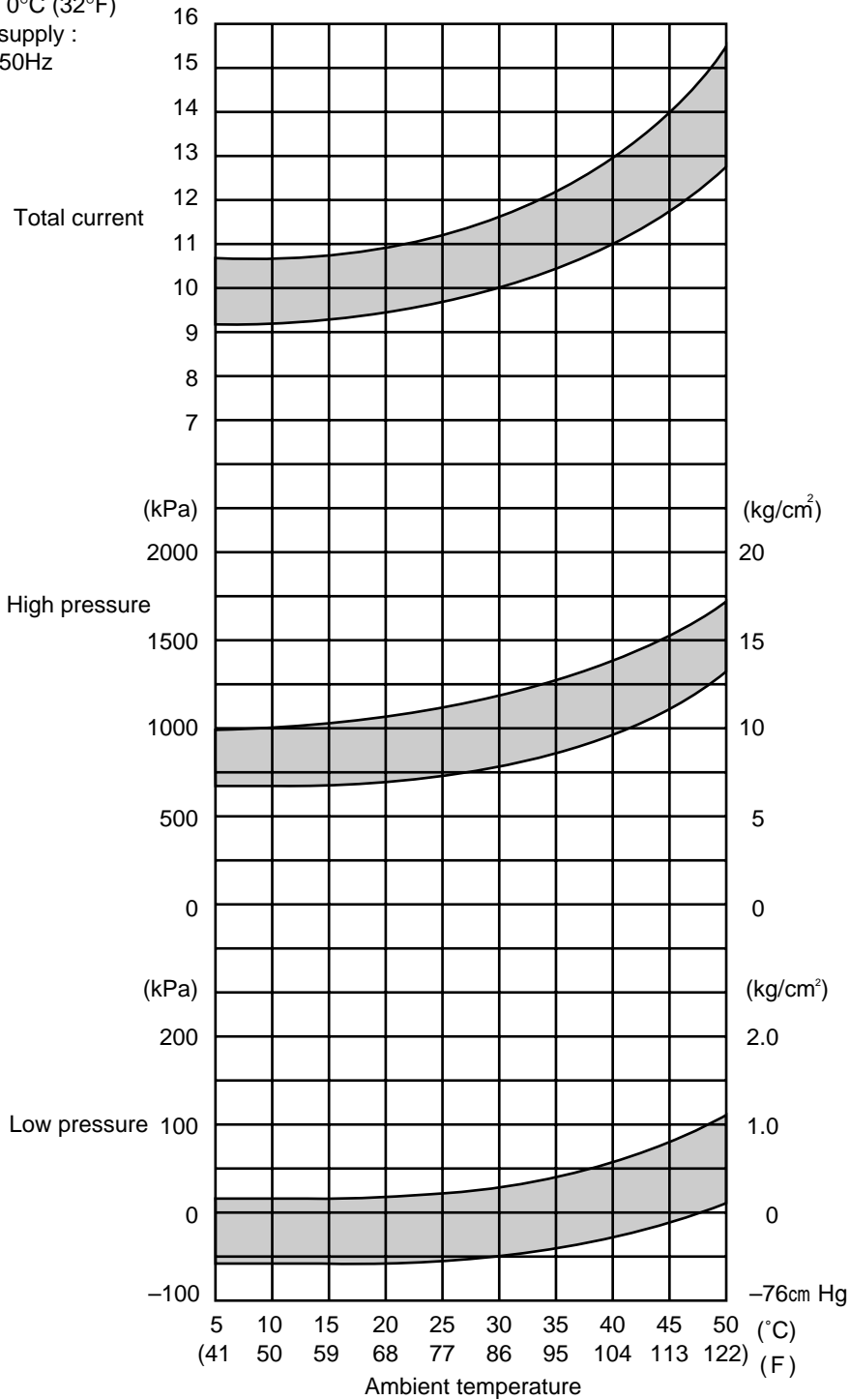

- Fan motor current

Item	Amperage	A
Condenser fan motor running current	1.3 (415VAC)	
Evaporator fan motor running current (2 motors)	2.9 (415VAC) Hi speed	

●Chilled mode
 Inside : 0°C (32°F)
 Power supply :
 440V / 60Hz

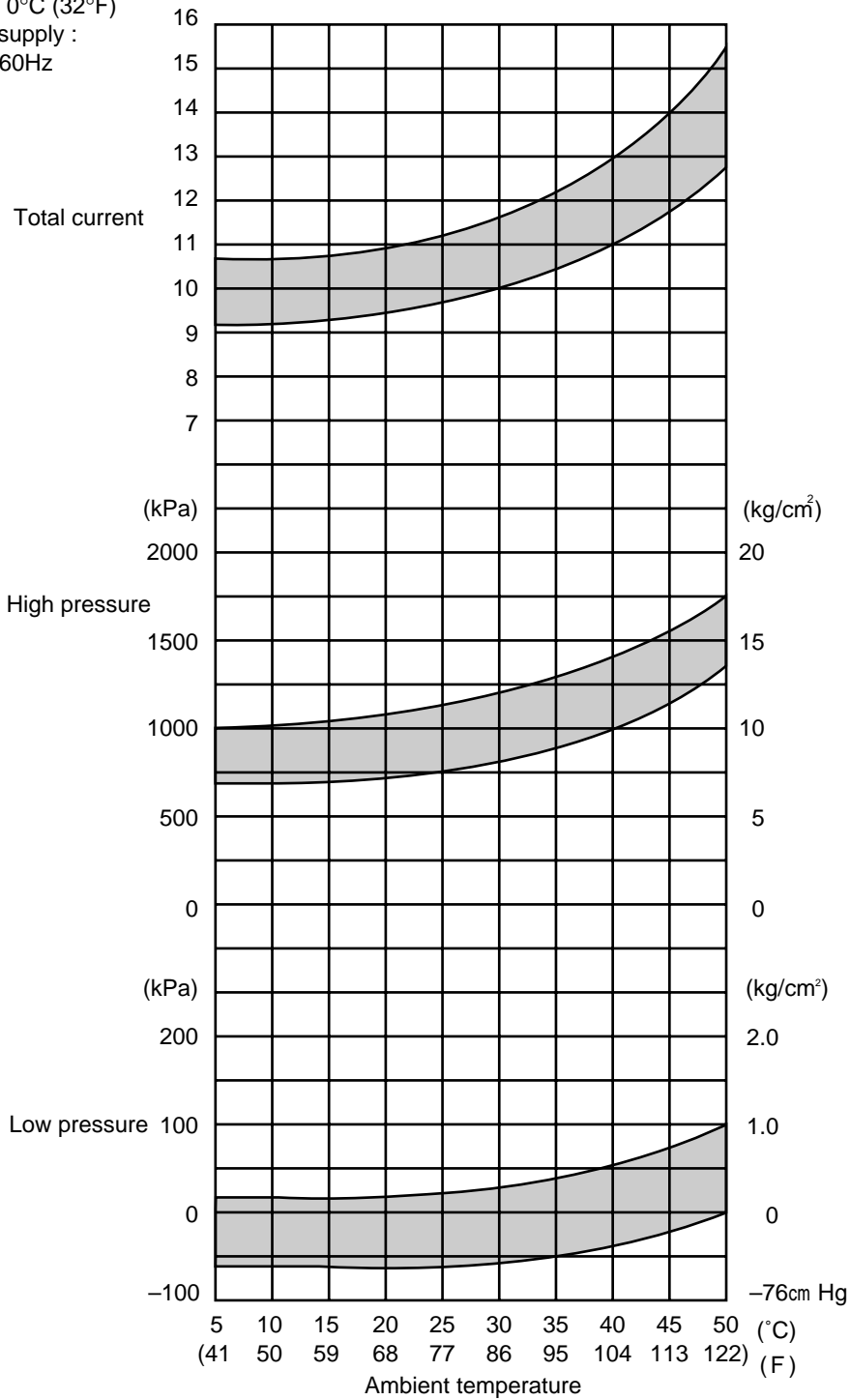

●Fan motor current

Item	Amperage	A
Condenser fan motor running current	1.3 (440VAC)	
Evaporator fan motor running current (2 motors)	2.9 (440VAC) Hi speed	

●Frozen mode

Inside: -18°C (-0.4°F)

Power supply: 415V, 50Hz

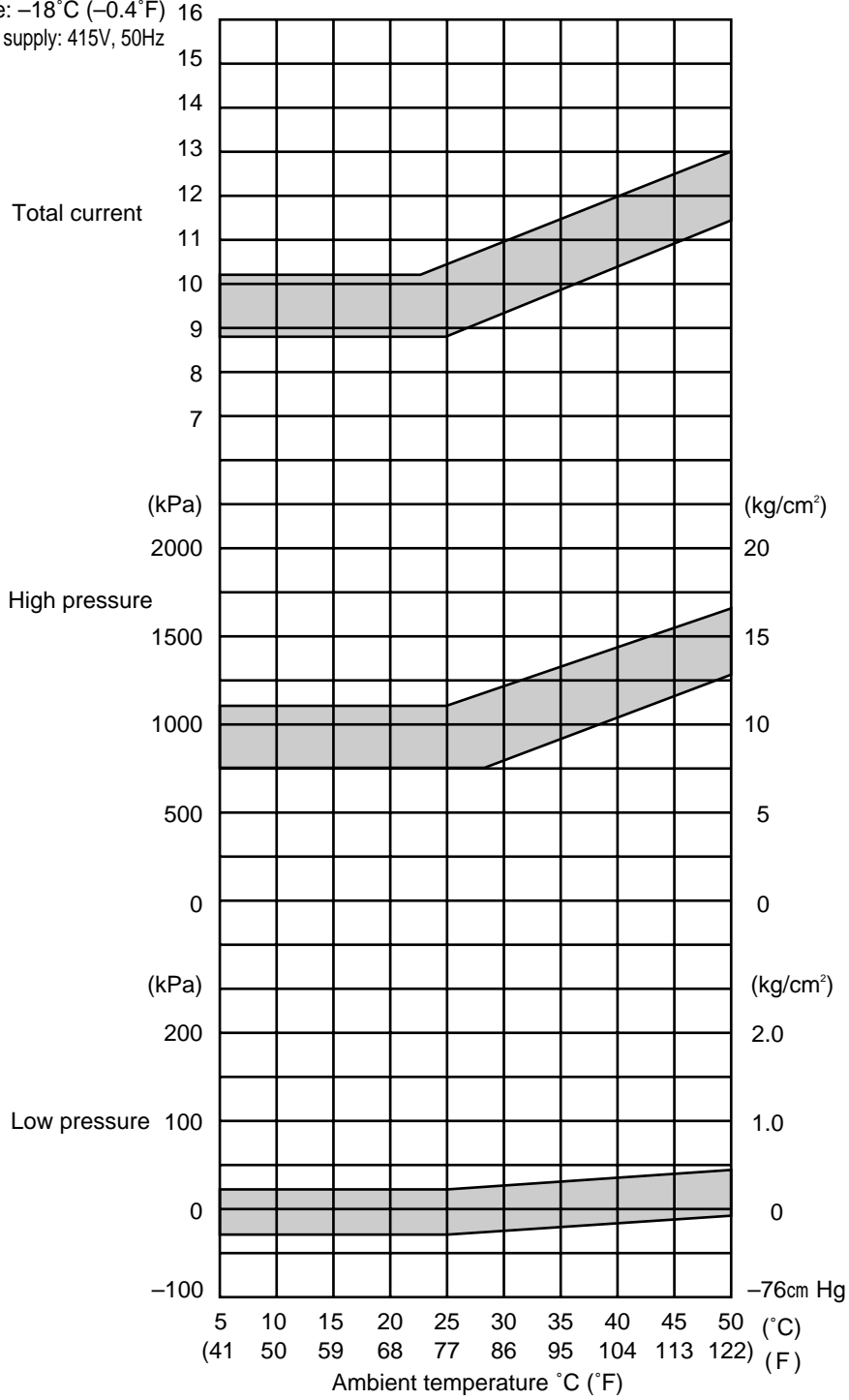

●Fan motor current

Item	Amperage	A
Condenser fan motor running current	1.3 (415VAC)	
Evaporator fan motor running current (2 motors)	0.8 (415VAC) Low speed	

●Frozen mode

Inside: -18°C (-0.4°F)
Power supply: 440V, 60Hz

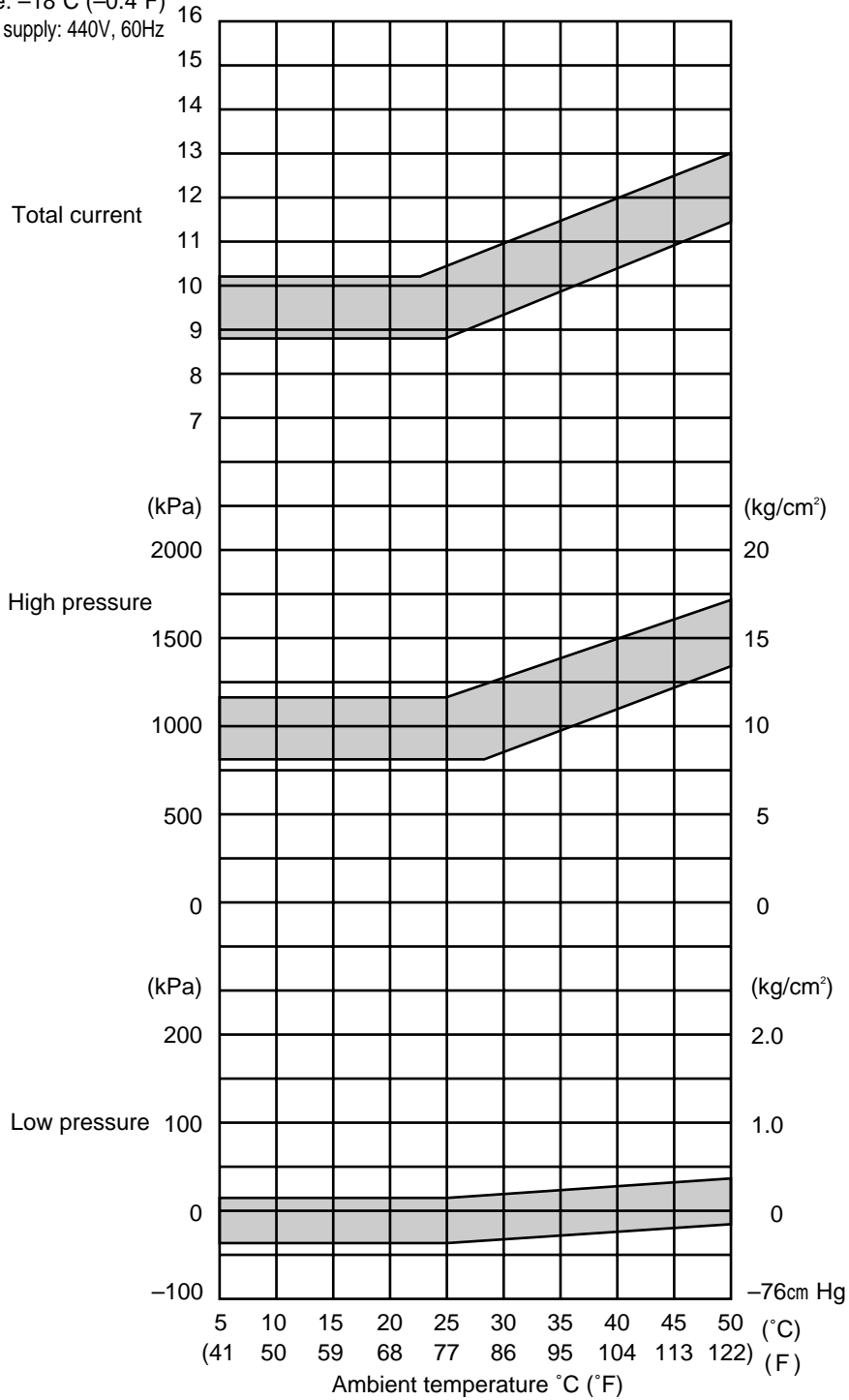

●Fan motor current

Item	Amperage	A
Condenser fan motor running current	1.3 (440VAC)	
Evaporator fan motor running current (2 motors)	0.8 (440VAC) Low speed	

2.5 OPERATION MODES AND CONTROL

There are two main types of operation modes: the cargo cooling control mode and the unit inspection mode.

The cargo cooling control mode is explained in this section.

※For the unit inspection mode, refer to section 3.9.

The relationship between the operation mode and setting temperature is as follows.

Operation mode	Setting temperature	Control sensor	Operation description
Frozen mode	-5.1°C to -30.0°C (+22.8°F to -22.0°F)	Return air temperature sensor	Compressor ON/OFF control
Chilled mode	+30.0°C to -5.0°C (+86°F to +23°F)	Supply air temperature sensor	Capacity control operation with suction modulating valve and hot-gas bypass control
Defrosting mode	-	-	Hot-gas defrosting with refrigerant metering control

※For details, refer to section 3.1 to 3.4.

2.5.1 Frozen mode

Control state transition and common control

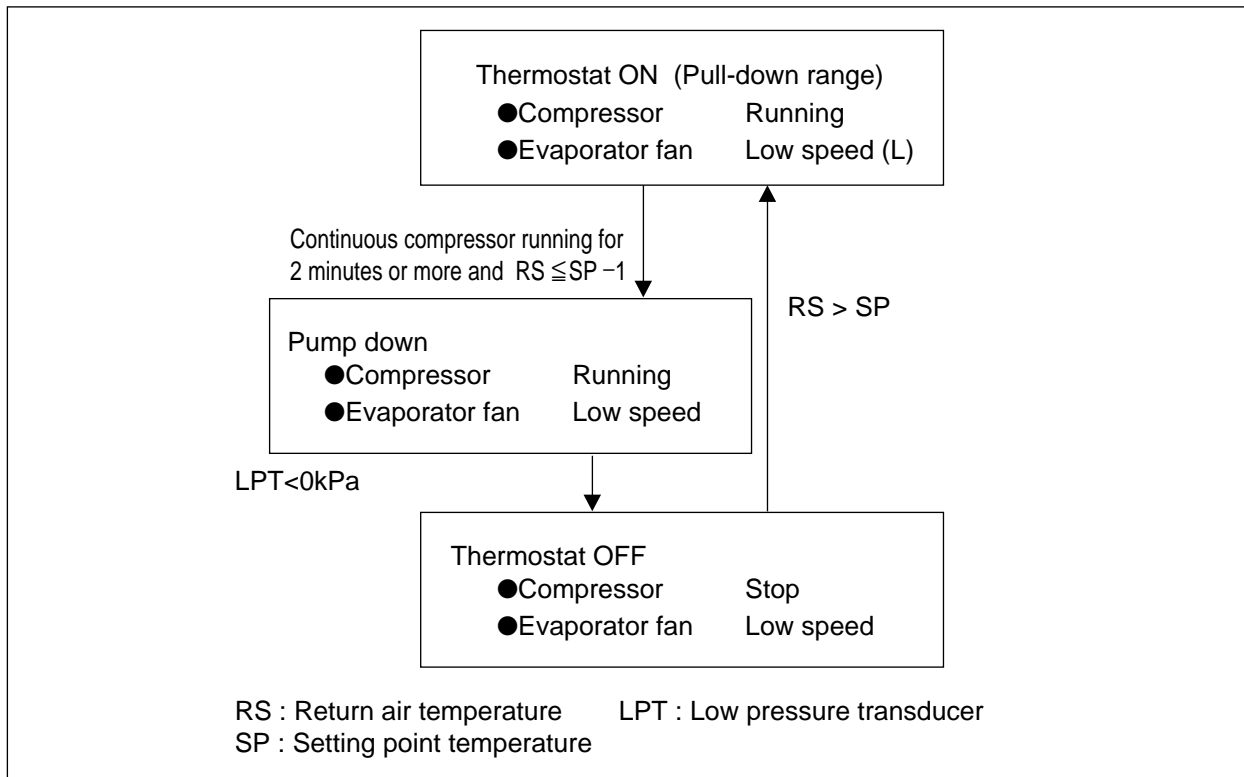

Operation of magnetic contactor and solenoid valve

Component name		Thermostat ON	Pump down	Thermostat OFF	
Magnetic contactor	Compressor	CC	ON	ON	OFF
	Evaporator fan. High speed	EFH	OFF	OFF	OFF
	Evaporator fan. Low speed	EFL	ON	ON	ON
	Condenser fan	CF	ON / OFF※1	ON / OFF※1	OFF
Solenoid valve	Liquid solenoid valve	LSV	ON	OFF	OFF
	Economizer solenoid valve	ESV	ON(OFF※3)	ON(OFF※3)	OFF
	Injection solenoid valve	ISV	OFF(ON※2)	OFF(ON※2)	OFF
	Hot-gas solenoid valve	HSV	OFF	OFF	OFF
	Defrost solenoid valve	DSV	OFF	OFF	OFF
	Discharge gas by-pass solenoid valve	BSV	OFF	OFF	OFF
	Capillary solenoid valve	CSV	OFF	OFF	OFF
Suction modulating valve	SMV	100%			
Electronic expansion valve	EV	10 to 100%			

Note) ※1: High pressure control

※2: Injection control (Refer to Page 2-25)

※3: Economizer control (Refer to Page 2-26)

(1) Set point temperature and control sensor

When the set point temperature (referred to as SP hereafter) is $-5.1^{\circ}\text{C}(+22.8^{\circ}\text{F})$ or lower, the compressor is operated ON and OFF, in response to return air temperature.

(2) Control

- ① When the control temperature reaches $\text{SP}-1.0^{\circ}\text{C}$ (point A), the compressor and condenser fan are turned off after the liquid solenoid valve has been de-energized and the pump down operation has been completed.
- ② When the control temperature exceeds SP, the compressor, liquid solenoid valve and condenser fan are turned on. However, the compressor runs for at least 2 minutes every time once it is turned on. Even if the control temperature becomes SP or lower (point C) within 2 minutes after the compressor is turned on, the compressor, condenser fan and liquid solenoid valve are not turned off. (2 minutes compressor forced operation)

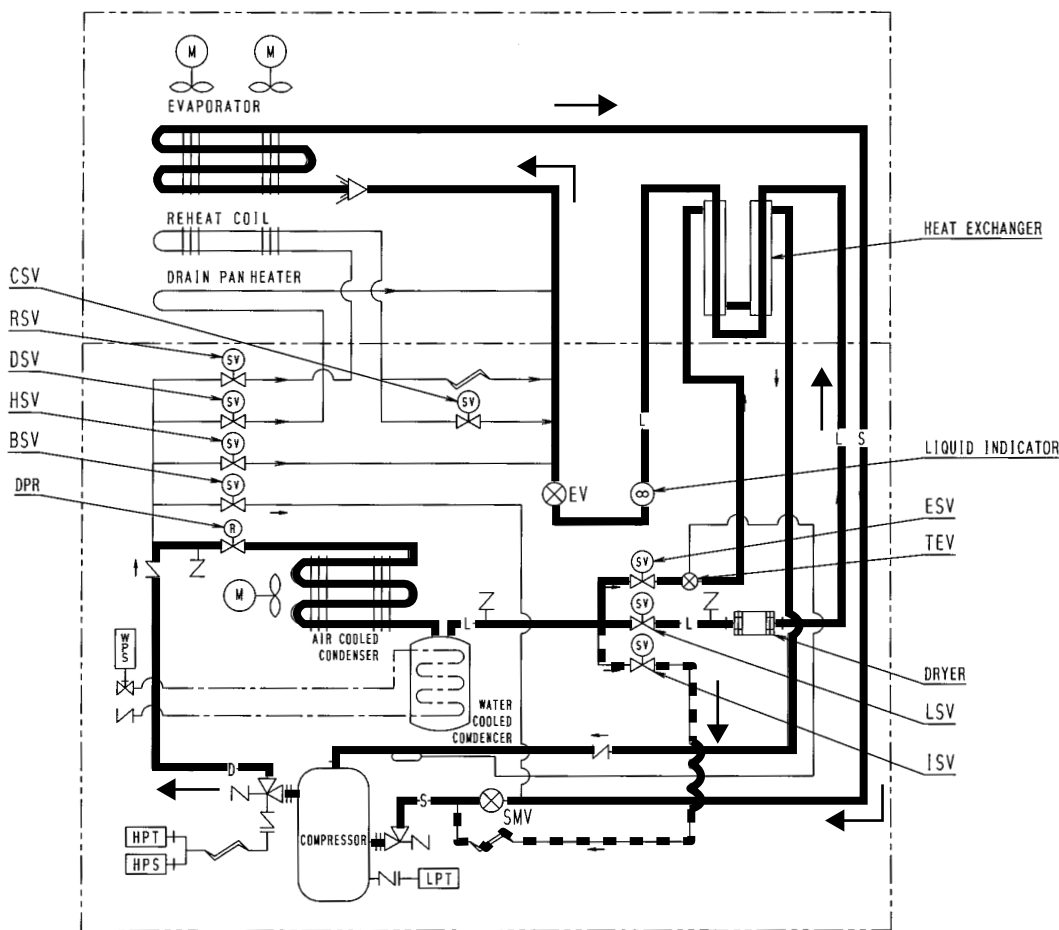
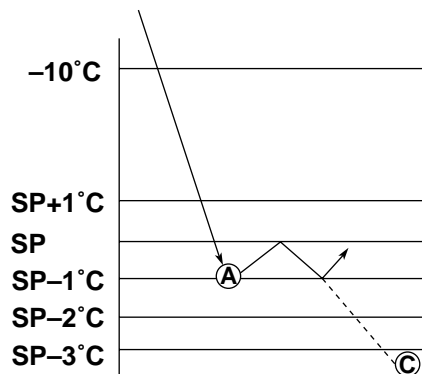

FROZEN (Return air $< 5^{\circ}\text{C}$)

- | | |
|-----------------------------------|--|
| EV: Elec. Exp. Valve | HSV: Hot Gas Solenoid Valve |
| LSV: Liquid Solenoid Valve | ISV: Injection Solenoid Valve |
| DSV: Defrost Solenoid Valve | BSV: Discharge gas Bypass Solenoid Valve |
| ESV: Economizer Solenoid Valve | LPT: Low Pressure Transducer |
| DPR: Discharge pressure regulator | HPT: High Pressure Transducer |
| SMV: Suction Modulation Valve | HPS: High Pressure Switch. |
| WPS: Water pressure switch | CSV: Capillary solenoid valve. |

2.5.2 Chilled mode

Control state transition and common control

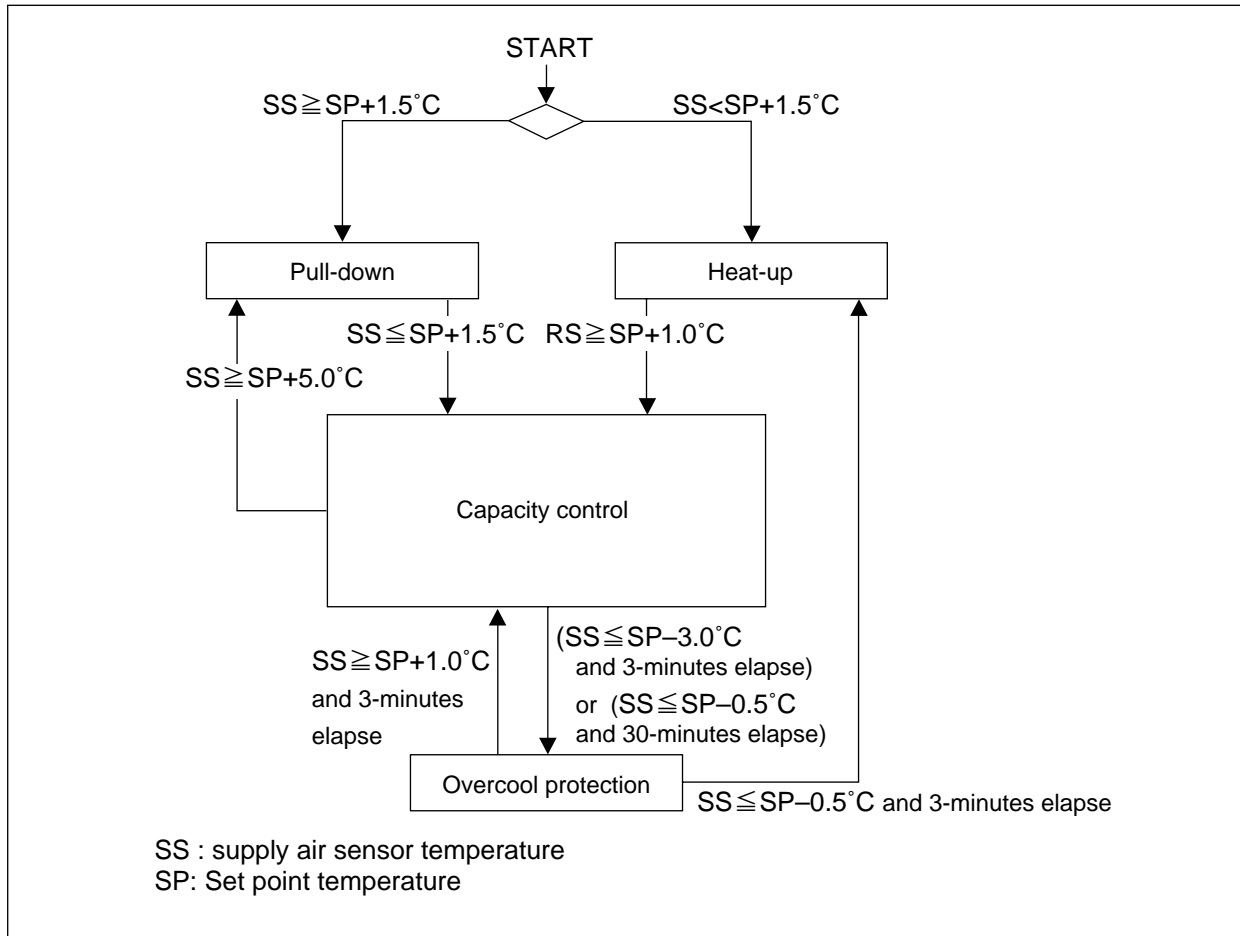

Operation of magnetic conductor and solenoid valve

Component name		Pull-down	Capacity control	Heat-up	Overcool protection	
Magnetic conductor	Compressor	CC	ON	ON	OFF	
	Evaporator fan. High speed	EFH	ON	ON	ON	
	Evaporator fan. Low speed	EFL	OFF	OFF	OFF	
	Condenser fan	CF	ON / OFF※1	ON / OFF※4	ON / OFF※1	OFF
Solenoid valve	Liquid solenoid valve	LSV	ON	OFF	OFF	
	Economizer solenoid valve	ESV	ON / OFF※5	OFF	OFF	
	Injection solenoid valve	ISV	ON / OFF※2	ON / OFF※4	ON / OFF※3	OFF
	Hot-gas solenoid valve	HSV	OFF	ON / OFF※4	ON	OFF
	Defrost solenoid valve	DSV	OFF	ON / OFF※4	ON	OFF
	Discharge gas by-pass solenoid valve	BSV	OFF	ON / OFF※4	OFF	OFF
	Capillary solenoid valve	CSV	OFF	OFF	OFF	OFF
Suction, modulating valve		SMV	12 to 100%※1	3 to 100%	100%	100%
Electronic expansion valve		EV	10 to 100%	10 to 100%	0%	50%

Note) ※1: High pressure control ※2: Discharge gas temperature control
 ※3: Charge control ※4: Capacity control and hot gas by-pass ※5: Economizer control

(1) Set point temperature and control sensor

- Chilled operation

When the set point temperature is -5.0°C (-41°F) or higher, the suction modulating valve (SMV) is controlled sensing the supply air temperature in order to adjust the cooling capacity.

(2) Control

- (a) Pull-down operation

Pull-down operation is carried out with fully opened suction modulating valve when the control temperature is higher than the set point temperature for 1.5°C or more (point ①).

- (b) Capacity control operation

When the control temperature reaches the point ②, the in-range lamp is turned on. At the same time, the suction modulating valve is activated to conduct the capacity control operation.

The control temperature converges to the set point temperature (point ③) while repeats temperature increasing and decreasing.

During capacity control, hot gas by-pass (HSV, DSV, BSV) and liquid injection (ISV) are conducted in order to maintain the optimum operation condition of refrigerant system.

- (c) Heat-up operation

When the control temperature is lower than [set point temperature $+1.5^{\circ}\text{C}$] (point ④), the heat-up operation using hot gas is conducted in order to raise the return air temperature to the [set temperature $+1.5^{\circ}\text{C}$] (point ⑤).

- (d) Overcool protection operation

Although the unit's operation is in a stable state, if the control temperature lowers below set point temp -3°C (point ⑥), the compressor stops and only the evaporator fan continues to operate.

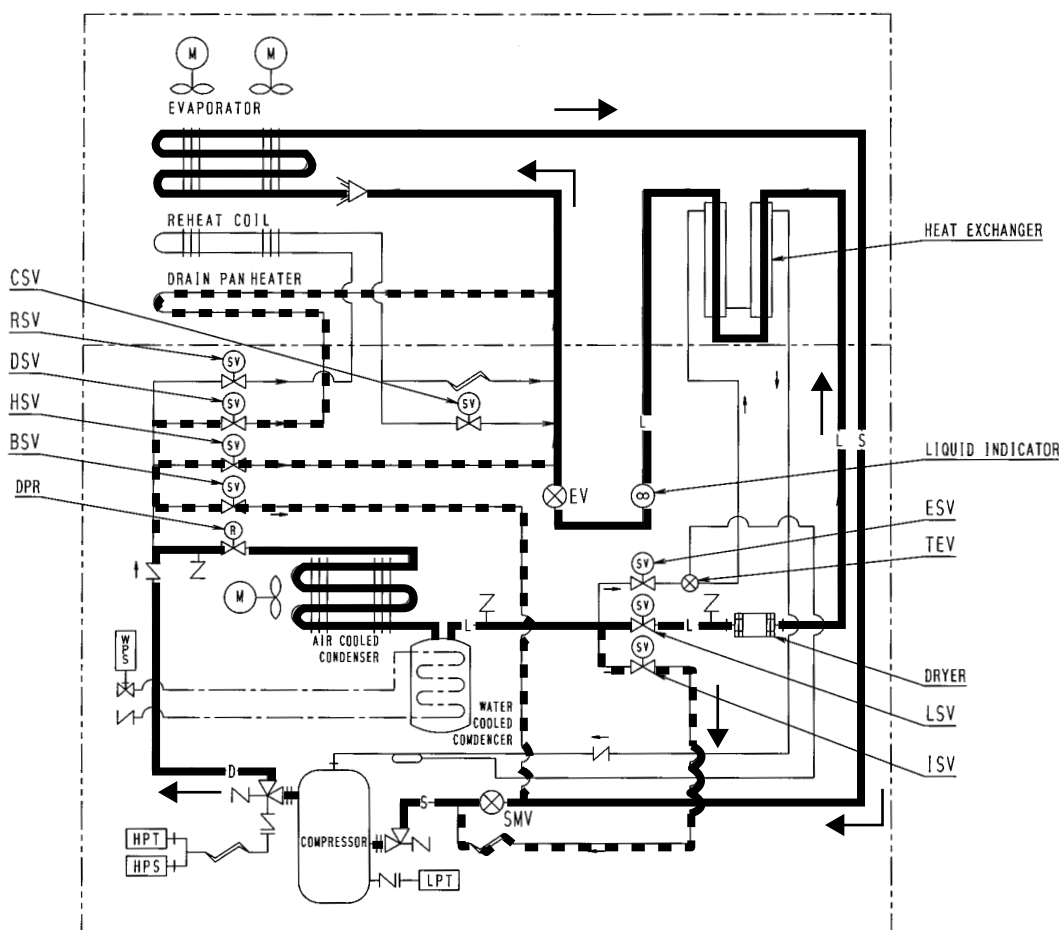
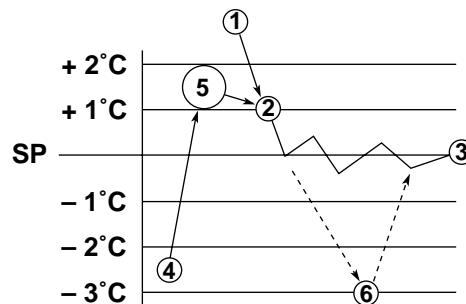

2.5.3 Defrosting mode

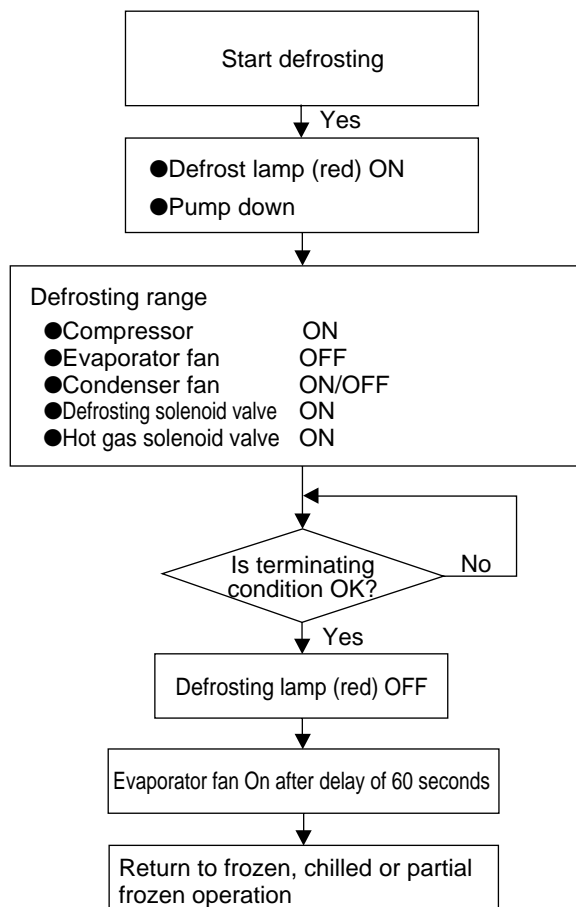

Operation of magnetic contactor and solenoid valve

		Component name	Pump down	Defrosting	
Magnetic contactor		Compressor	CC	ON	
		Evaporator fan. High speed	EFH	ON/OFF※3	
		Evaporator fan. Low speed	EFL		
		Condenser fan	CF	ON/OFF※1	ON/OFF※1
Solenoid valve		Liquid solenoid valve	LSV	OFF	OFF
		Economizer solenoid valve	ESV	ON/OFF※4	OFF
		Injection solenoid valve	ISV	OFF (ON※5)	ON/OFF※2
		Hot-gas solenoid valve	HSV	OFF	ON
		Defrost solenoid valve	DSV	OFF	ON
		Discharge gas by-pass solenoid valve	BSV	OFF	OFF
		Reheat solenoid valve	RSV	OFF	OFF(ON※6)
	Capillary solenoid valve	CSV	OFF	OFF	
	Suction modulating valve	SMV	100%	100%	
	Electronic expansion valve	EV	10 to 100%	5%	

Note) ※1: Pressure control

※2: Charging control

※3: Frozen mode ... EFL ON, Chilled mode ... EFH ON

※4: Economizer control

※5: Discharge gas temperature control

※6: EOS>15°C

Defrosting operation

(1) Defrosting system

A hot-gas defrost system is adopted in the units; i.e. the high temperature and high pressure refrigerant (hot gas) from the compressor is sent to the evaporator and drain pan for defrosting. Since the evaporator is heated directly by the hot gas (refrigerant), defrosting can be performed effectively.

(2) Defrosting initiation

Defrosting is initiated by the timer or the manual defrost key.

However, defrosting is not initiated when frosting on the evaporator can not be detected.

- Evaporator inlet temperature : 5°C or higher
- Evaporator outlet temperature : 20°C or higher

① Initiation by timer (Timer is set at the electronic controller, refer to section 3.3.2 for its operating method.)

Type of timer	Defrosting interval set	Function
Long timer	3, 6, 9, 12, 24 and 99* ¹ hours are selectable.	Regardless of the control temperature, defrosting is initiated according to the selected interval.
Short timer	4 hours* ²	Defrosting is initiated every 4 hours until the control temperature comes within the in-range after pull-down. When the temperature is in-range, defrosting timer will change into the selected long timer.
Out-range timer	30 minutes	After the control temperature comes within in-range once, defrosting will be started 30 minutes later if the control temperature rises out of the in-range.

※1. Refer to "(3) On-demand defrost"

※2. 6 hours when the control temperature is -20°C or below.

② Starting by MANUAL DEFROST key (on the operation panel sheet key)

Press the MANUAL DEFROST key, then press the ENTER/ESC key while indicate "ON" on the LED display. The manual defrosting operation starts.

③ Initiation by frost detection

If the suction air temperature does not drop at the speed of 0.2°C/1hr during frozen pull-down operation, defrosting will be initiated because it is judged that frost is formed on the evaporator. However, if the suction temperature is -20°C or lower, defrosting will not be initiated. (activated)

(3) On demand defrost

When "99" in long timer is selected, defrosting is activated upon the condition of frost on evaporator coil. This function is only for Frozen setting (SP < -10.1 deg C). and starting with 12 hours. (If this function is selected for chilled setting, defrost initiates every 6 hours automatically.)

Procedure:

Step 1: After defrost, the controller records compressor running time for 1st 1 hour. (T1)

Step 2: When 12 hours passed after defrost, controller records compressor running time for last 1 hour (T2). And the controller check whether the below condition is satisfied.

$$T2 > T1 \times 1.15$$

Step 3: If the above condition is satisfied, defrost is activated.

If above condition is not satisfied, defrost is postponed another one hour.

After counting up 13 hours, then repeat "Step 2".

Defrost will be postponed every one hour until the above condition (Step 2) is satisfied. (Max. 24 hours)

(4) Defrosting termination

Defrosting will be terminated when any one of the following three conditions is satisfied.

① The below figure is satisfied during defrost.

Status before defrost	Termination
INRANGE	$EOS \geq 30.0^{\circ}\text{C}$
OUTRANGE	$EOS \geq 30.0^{\circ}\text{C}$ & $RS/DRS \geq 15^{\circ}\text{C}$

② 90 minutes have elapsed.

③ Any one of protective devices is activated.

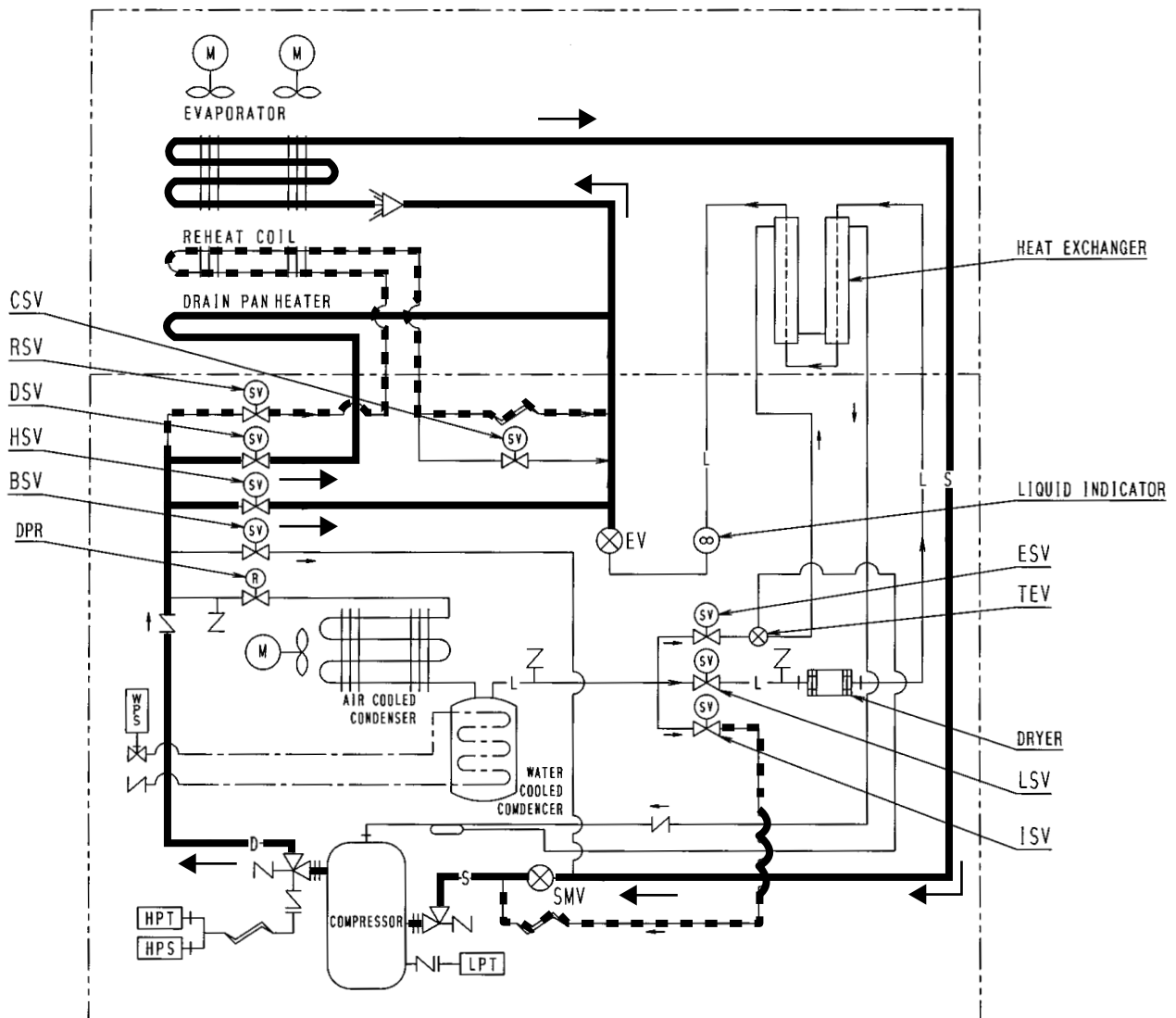

2.5.4 Dehumidification

※If reheat coil and humidity sensor (Optional) is equipped:

The unit have dehumidification control by a reheat coil, which is under the evaporator coil. To execute dehumidification, controller setting is required. (Refer to Page 3-12)

In dehumidification, the Reheat Solenoid Valve (RSV)/Capillary Solenoid Valve (CSV) opens to give high pressurized refrigerant to reheat coil. The "DEHUMID" LED lamp will light up.

The following setting can be made:

- 1) Dehumidification range: 30%RH–95%RH

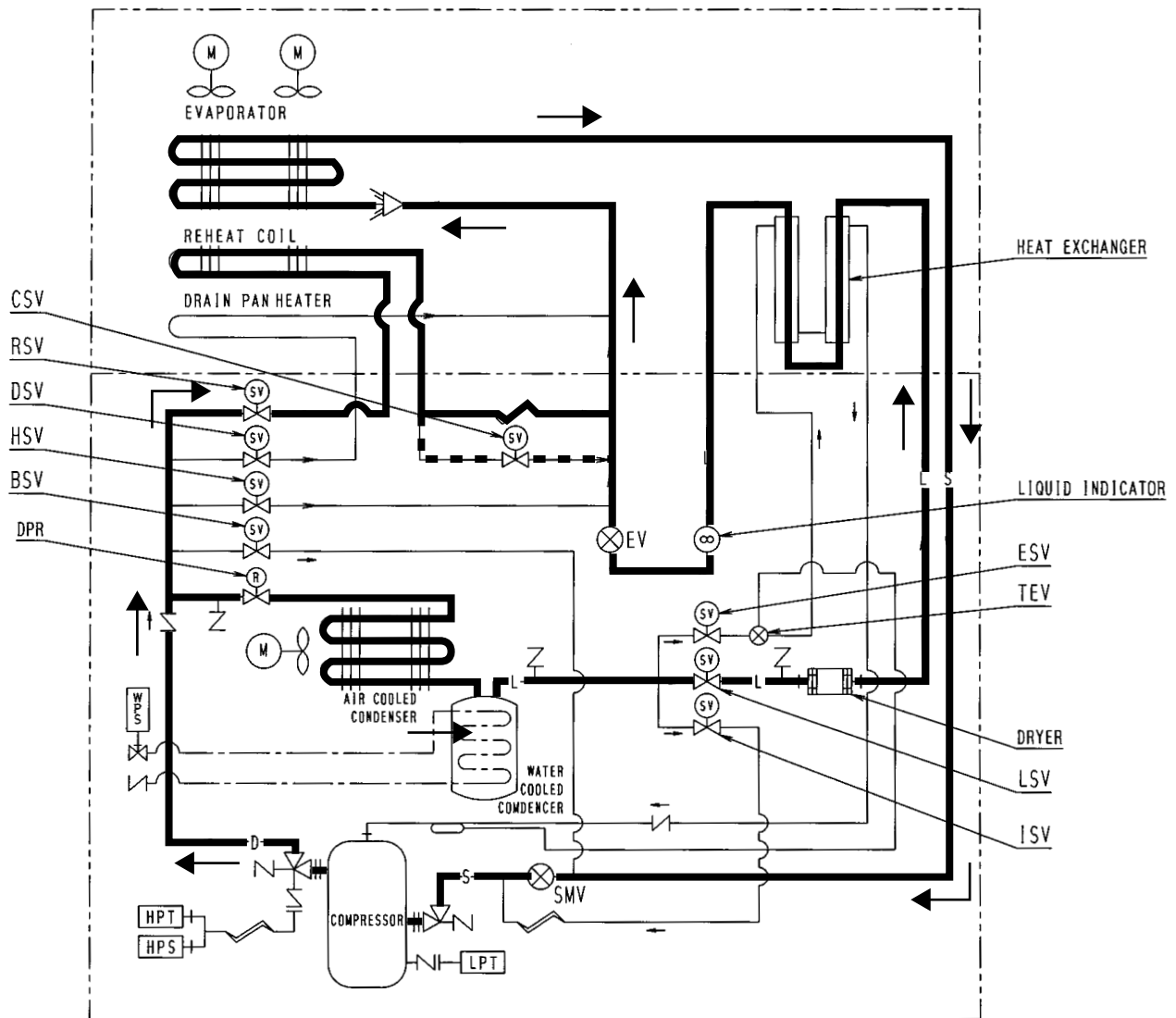

2.5.5 Common control

The following are controlled in different operation modes. (For the details, refer to the following pages.)

	Control name	Control content	Operation mode		
			Frozen	Chilled	Defrost
A	Compressor ON/OFF control	The compressor is operated on and off to adjust the inside temperature.	○		
B	Starting control	<ul style="list-style-type: none"> At the start of the operation with low ambient temperature, an oil temperature raising control is executed. When a protection device activates at the operation start, a high pressure/current control is executed. 	○	○	
C	Evaporator fan speed control	The evaporator fan is switched to the high or low speed according to the set point temperature.	○	○	
D	Superheat control	In order to keep the superheat of the evaporator optimum, the opening of the electronic expansion valve is controlled.	○		
E	High-pressure control	In order to keep the high pressure optimum, the opening of the electronic expansion valve is controlled.	○	○	
F	Injection	In order to prevent the refrigerant oil from deteriorating, the injection solenoid valve control or electronic expansion valve control is carried out.	○	○	
G	In-range control	When the control temperature is within $SP \pm 2^{\circ}\text{C}$, the in-range lamp is turned on.	○	○	
H	In-range masking control	After defrosting initiation, the in-range lamp is kept on for 90 minutes.	○	○	○
I	Capacity control	The circulating flow rate of refrigerant is proportionally controlled with suction modulating valve to keep the control temperature variation within $\pm 0.5^{\circ}\text{C}$.		○	
J	Charging and releasing control	These functions control the heating capacity for defrosting and heating operation.		○	○
K	Pump down control	The liquid refrigerant is collected into the liquid receiver (water cooled condenser).	○	○	○
L	Economizer control	The economizer circuit is controlled to enhance cooling capacity.	○	○	
M	Condenser fan control in water-cooled operation	The condenser fan is controlled to prevent the temperature rise in the control box.	○	○	○

Common control

A : Compressor ON/OFF control

When the control temperature reaches the [set temperature -1.0°C] or lower, the compressor is stopped. When the control temperature rises and becomes higher than the [set point temperature], the compressor runs again.

When the compressor starts running it is forcibly run for 2 minutes. (2 minutes compressor forced operation) in order to prevent the compressor from deterioration due to shortage of lubricant.

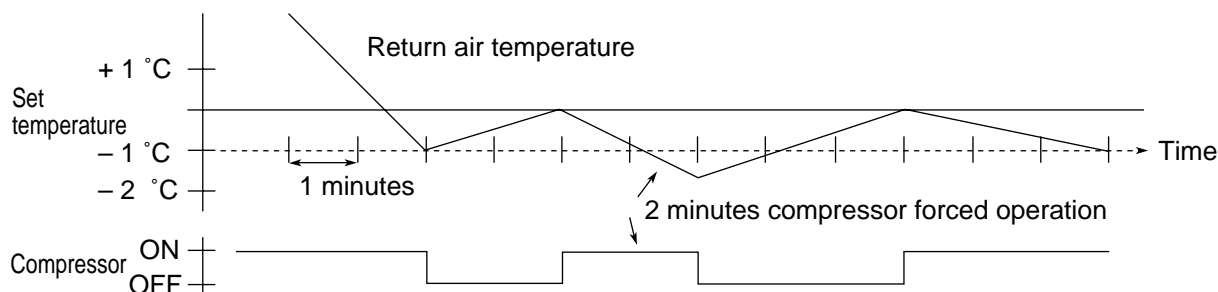

B : Starting control

- Control when protective device activated

When the high pressure rapidly rises on starting or when the starting current is overcurrent, the compressor automatically stops and starts to suppress high pressure and starting current.

- Temperature control of refrigerant oil

When ambient temperature is low, the temperature refrigerant oil for compressor is also low and the viscosity of the oil may be high.

On starting the unit, by-pass discharge gas to suction side of the compressor by opening the solenoid valve (BSV) to raise the oil temperature rapidly ensuring a stable feed of oil.

In order to control the oil temperature of refrigerating machine or in the event the high pressure is low, operate the compressor with the condenser fan stopped. If the high pressure reaches 1500 kPa or more, the fan will restart to operate.

The temperature control for refrigerant oil should be executed not with power ON/OFF in normal operation but with power ON under low ambient temperature.

An oil temperature raising control can be executed when all of the following conditions are met.

- The time turning power supply ON
- Ambient temperature $\leq 10^{\circ}\text{C}$
- (Discharge gas temperature – ambient temperature) $\leq 4^{\circ}\text{C}$

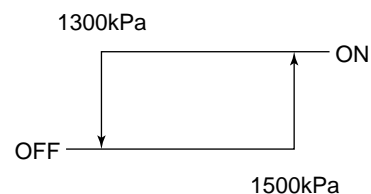

C : Evaporator fan speed control

The speed of the evaporator fan is switched in accordance with operation modes. A delay time of 10 sec. is provided to switch the high speed to low speed and vice versa.

Chilled mode : High speed
 Partial frozen mode : High speed
 Frozen mode : Low speed

D : Superheat control

The evaporator superheat is adjusted to be optimum by controlling the opening of the electronic expansion valve, based on the evaporator inlet and outlet refrigerant temperature, and the compressor suction gas temperature.

E : High-pressure control

- By suction modulating valve

When the ambient temperature is high during the air-cooled or water-cooled operation, the condensing pressure (high pressure) will increase, and the high pressure switch may be activated.

In order to prevent this situation, the high pressure is controlled to be 2350kPa or lower by adjusting the opening of the suction modulating valve.

- By condenser fan

When the ambient temperature is low during the air-cooled operation, the condenser pressure (high pressure) will decrease. Accordingly, the low pressure will decrease.

In order to prevent this situation, when the high pressure becomes set point or lower, the condenser fan stops to prevent the high pressure from excess dropping.

When the high pressure becomes set point or higher afterwards the operation will be restarted.

This control varies upon dehumidification setting.

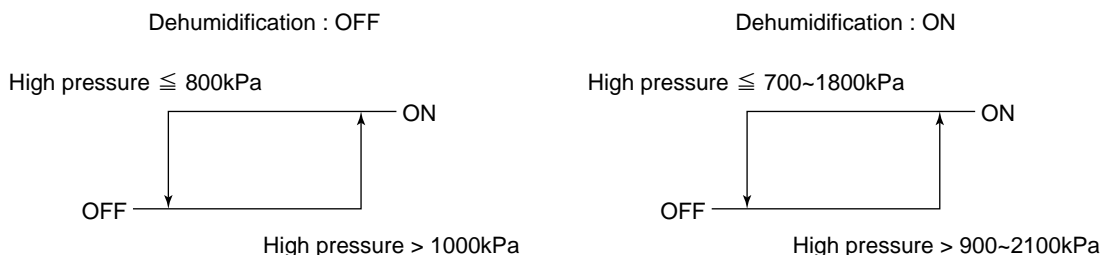

F : Injection control

In order to decrease the discharge gas temperature, inject liquid refrigerant into the suction pipe.

- During normal compressor operation

The injection solenoid valve will be turned on or off to control the discharge gas temperature lower than set point.

The control is conducted properly by using detected discharge gas temperature and inside temperature.

Discharge gas temperature (DCHS) set value

	Frozen, chilled (pull-down)		Chilled, capacity control
	RS \leq 0°C	RS > 0°C	
ISV ON	120°C	128°C	113°C
ISV OFF	103°C	118°C	108°C

- Defrosting / Heat-up operation

Control the injection ON/OFF with charge control. For details, see the section of "charge control" on page 2-20.

G : In-range control

In order to observe at a glance whether the refrigeration unit properly controls the inside temperature or not, the orange lamp on the display panel will light up when the control temperature is near the set point temperature (SP).

H : In-range masking control

If the inside temperature is within the in-range when defrosting is started, the in-range lamp will be kept turned on forcibly for certain period as below regardless of the inside temperature thereafter.

This will avoid misunderstanding that there is a problem as the control temperature temporarily rises during defrosting.

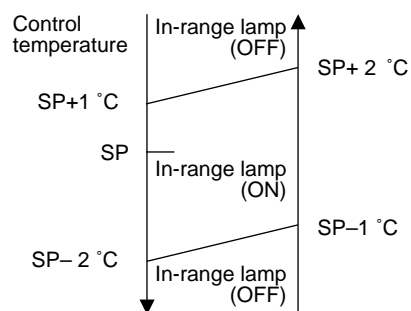

Setpoint \geq -20.0°C	90 minutes
Setpoint \leq -20.1°C	120 minutes

I : Capacity control

In the chilled mode operation, adjusting cooling capacity makes the supply air temperature stable at the set point temperature (SP).

The capacity control is executed by adjusting the opening of suction modulating valve (SMV) between 3 to 100 %.

J : Charge and release control

Charge control or release control is executed to maintain the heating capacity optimum in defrosting and heating operation.

• Charge control

- ① The suction pressure (LPT) is detected and the injection solenoid valve (ISV) is turned on, then, liquid refrigerant is charged into the suction pipe.
- ② The discharge pressure (HPT) is detected and the injection solenoid valve (ISV) is turned on, then the liquid refrigerant is charged into the suction piping.

• Release control

The discharge pressure (HPT) is detected and the condenser fan (CFM) is turned on, then, the refrigerant is released into the condenser.

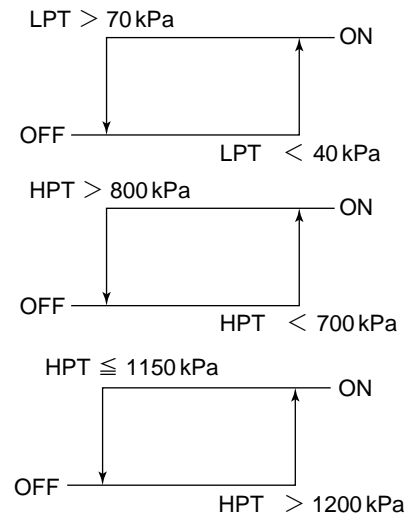

K : Pump down stop

Before the thermostat turns OFF and at the start of defrosting, close liquid solenoid valve (LSV) to conduct pump down operation and recover refrigerant in the receiver. When the low pressure reaches -50kPa or lower, the pump down is terminated.

L : Economizer control

The economizer circuit for which the intermittent injection to scroll compressor and the refrigerant heat exchanger are combined, is adopted in the unit.

The economizer circuit enables the liquid refrigerant to have wide range of subcooling resulting in a significant increase of cooling capacity.

• Economizer solenoid valve (ESV) control

Frozen mode: ON with return air temperature (RS) of 5°C or lower

Chilled & partial frozen mode: ON with return air temperature (RS) of 5°C or lower during pull-down operation

During capacity control, the control does not turn ON.

M : Condenser fan control in water-cooled operation

This refrigeration unit is functional either in air-cooled operation or in water-cooled operation. The selection of air-cooled operation and water-cooled operation is automatically made through the water pressure switch. In other words, when cooling water flows in the water cooled condenser to apply water pressure to the inlet of the condenser, a contact in the water pressure switch will open to stop the condenser fan motor, thus switching the unit to water-cooled operation. By contrast, if feeding water stops in water-cooled operation, a contact in the water pressure switch will be closed to run the condenser fan motor, thus switching the unit to air-cooled operation.

- ※1 If the shortage of cooling water is caused in water-cooled operation, the condensing pressure will increase, thus activating the high pressure switch. In order to prevent this event, operate the condenser fan so that the condensing pressure will not increase in excess of a high-pressure (HPT) set point. When the high pressure falls below the set point, the condenser fan will stop running.

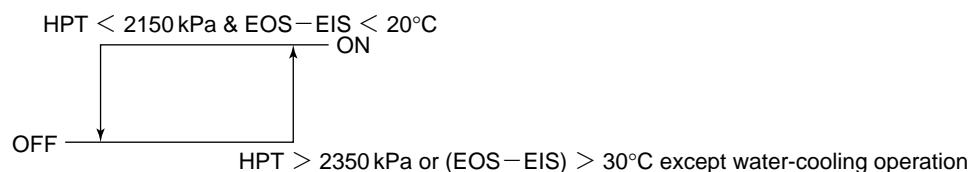

- ※2 If ambient temperature is high, a temperature in the control box will increase. If this temperature exceeds a value set with the control box thermostat (CBS), the condenser fan will start running to cool the control box.

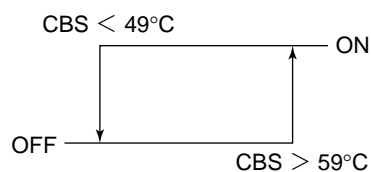

CAUTION

Even in water-cooled operation, there may be cases where the condenser fan operates.

3. ELECTRONIC CONTROLLER

3.1 Function table

●DECOS III d (Daikin Electronic Controller Operation System)

(Note) [PC]: Functions using personal computer

No.	Function division	Function	DECOS III d
1	Control function	<ul style="list-style-type: none"> • Temperature control • Defrosting control • Humidity control 	<ul style="list-style-type: none"> ✓ ✓ Optional
2	Initial setting	<ul style="list-style-type: none"> • With/without optional equipment (USDA, humidity) and horse power selection • Chartless function setting 	<ul style="list-style-type: none"> ✓ ✓
3	Setting	<ul style="list-style-type: none"> • Temperature • Defrosting interval • Humidity • [PC] --- Header information set of data logger 	<ul style="list-style-type: none"> ✓ ✓ ✓ ✓
4	Indication (Display panel)	<ul style="list-style-type: none"> • Operating mode (compressor running, defrosting, in-range temperature, dehumidifying) • Alarm • Return air temperature/set point temperature • Supply air temperature/set point temperature • Defrosting interval • Inside humidity/set point humidity • Ambient temperature • High pressure • Low pressure • Power supply voltage • Total operating current • Compressor operating current • Evaporator inlet temperature • Evaporator outlet temperature • Discharge gas temperature • Compressor suction gas temperature • Suction modulating valve opening • Electronic expansion valve opening • Return air temperature (during PTI only) • Supply air temperature (during PTI only) • Pulp temperature (USDA #1, #2, #3) • Cargo temperature • Fresh air quantity 	<ul style="list-style-type: none"> ✓ ✓ ✓ ✓ ✓ Optional ✓ ✓ ✓ ✓ ✓ ✓ ✓ ✓ ✓ ✓ ✓ ✓ ✓ ✓ ✓ ✓ ✓ ✓ ✓ ✓ ✓ ✓ ✓ Optional Optional Optional
5	Self-diagnosis and automatic back-up	<ul style="list-style-type: none"> • Sensor <ul style="list-style-type: none"> Return air temperature sensor Supply air temperature sensor Ambient temperature sensor High pressure sensor Low pressure sensor Voltage sensor Current sensor Evaporator inlet temperature sensor Evaporator outlet temperature sensor Discharge gas temperature sensor Compressor suction gas temperature sensor Humidity sensor Pulp temperature sensor Cargo temperature sensor Data recorder sensor • High pressure switch • Solenoid valve/hot gas modulating valve (leakage check) • Long defrosting • Over-voltage 	<ul style="list-style-type: none"> ✓ ✓ ✓ ✓ ✓ ✓ ✓ ✓ ✓ ✓ ✓ ✓ ✓ ✓ ✓ ✓ Optional Optional Optional Optional ✓ ✓ ✓ ✓

No.	Function division	Function	DECOS III d
5	Self-diagnosis and automatic back-up	<ul style="list-style-type: none"> • Open-phase running • Over current running • CPU and peripheral device (electronic controller) 	<ul style="list-style-type: none"> ✓ ✓ ✓
6	Manual inspection	<ul style="list-style-type: none"> • Compressor running hour indication • Evaporator fan individual operation (high speed) • Evaporator fan individual operation (low speed) • Condenser fan individual operation • Indication of elapsed time since trip start/time resetting • Evaporator fan run-hour indication • Condenser fan run-hour indication • Controller software version indication • [PC] --- Pulp temperature sensor/cargo temperature sensor calibration • [PC] --- Header information set of data logger • [PC] --- All sensor data indication • [PC] --- Controller built-in relay output display/MV output (opening rate) indication/EV output (opening rate) indication 	<ul style="list-style-type: none"> ✓ ✓ ✓ ✓ ✓ ✓ ✓ ✓ Optional ✓ ✓ ✓
7	Automatic PTI	<ul style="list-style-type: none"> • Automatic PTI (SHORT) = Operation check of components • Automatic PTI (FULL) 	<ul style="list-style-type: none"> ✓ ✓
8	Data logging	<ul style="list-style-type: none"> • Compressor total running hour • Evaporator fan motor total running hour • Condenser fan motor total running hour • Trip data • Pulp temperature data • Cargo temperature data • Fresh air quantity data • Alarm logging data • Automatic PTI data • Event data 	<ul style="list-style-type: none"> ✓ ✓ ✓ ✓ Optional Optional Optional ✓ ✓ ✓
9	Data retrieving (Data output)	<ul style="list-style-type: none"> • [PC] --- Alarm data • [PC] --- Trip data • [PC] --- Automatic PTI data • [PC] --- Pulp temperature data • [PC] --- Cargo temperature data • [PC] --- Event data 	<ul style="list-style-type: none"> ✓ ✓ ✓ Optional Optional ✓
10	Communication	<ul style="list-style-type: none"> • Remote monitoring • Remote control 	<ul style="list-style-type: none"> Optional Optional
11	Power back-up	<ul style="list-style-type: none"> ※Even while the power is off, the following works are possible. • Setting, Temperature setting Humidity setting Defrosting interval setting • [PC] --- Container ID data setting • Saving the logger data record • Data retrieving (down loading) 	<ul style="list-style-type: none"> Optional ✓ ✓ ✓ ✓ ✓
12	Chartless	<ul style="list-style-type: none"> • Alarm indication function (H code) • Operation history indication function (D code) • Pull-down time indication function (P code) • Temperature logging data indication on LCD in simple graphic chart 	<ul style="list-style-type: none"> ✓ ✓ ✓ ✓
13	G-SET mode	<ul style="list-style-type: none"> ※To be used when power supply capacity is small. • Energy saving operation 	<ul style="list-style-type: none"> ✓
14	Data scroll	<ul style="list-style-type: none"> • Temperature log scroll indication function • Alarm log indication function 	<ul style="list-style-type: none"> ✓ ✓
15	Data input	<ul style="list-style-type: none"> ※The following works are possible using the indication panel • Container ID (No.) entering • Controller time setting 	<ul style="list-style-type: none"> ✓ ✓
16	Automatic Pump down	<ul style="list-style-type: none"> • Refelgerant is collected into the receiver and condensor coil. 	<ul style="list-style-type: none"> ✓

3.2 BASIC OPERATION OF ELECTRONIC CONTROLLER

3.2.1 Control panel

Name and function of each components

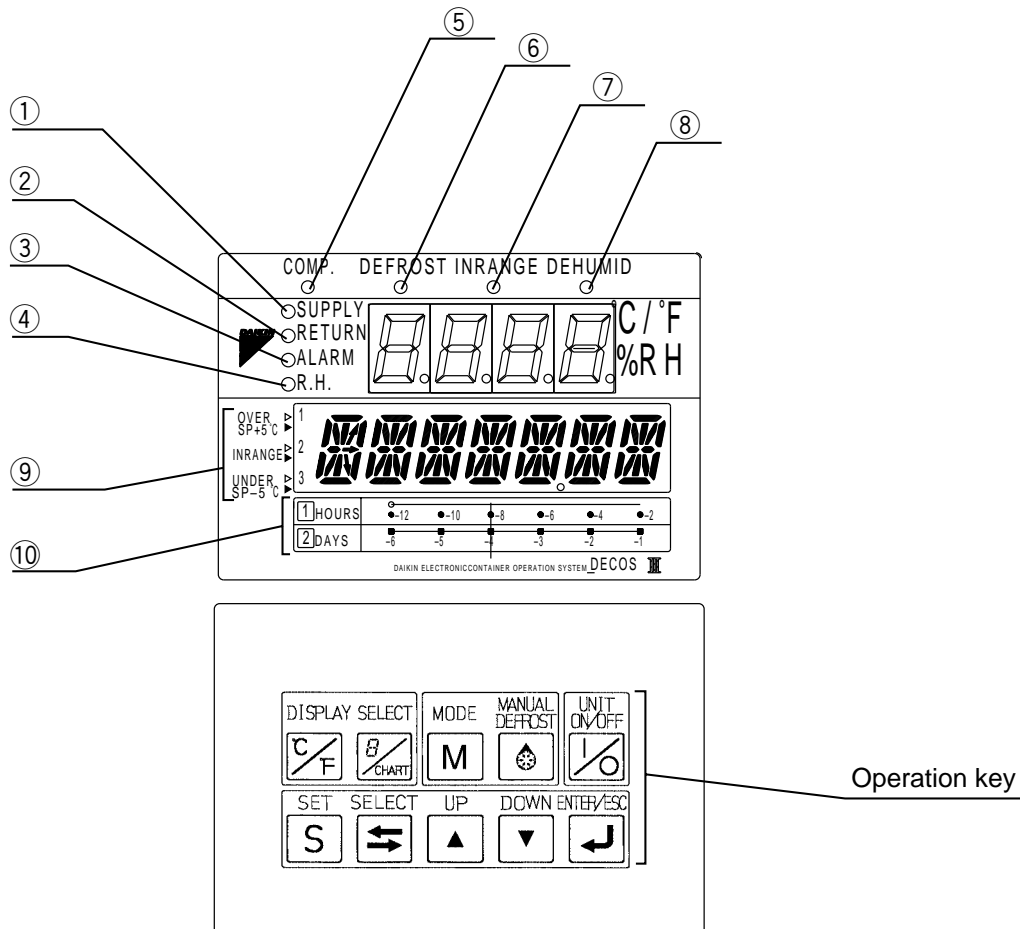

- | | |
|---|---|
| ① SUPPLY LED (Lights when "supply air temperature" is indicated.) | ⑦ IN RANGE LED (Lights when the control temperature is in range.) |
| ② RETURN LED (Lights when "return air temperature" is indicated.) | ⑧ DE-HUMID.LED (Lights when the controller is the dehumidification control optional.) |
| ③ ALARM LED (Lights when alarm is generated.) | ⑨ Temperature base (Used for the graphic chart indication on the LCD.) |
| ④ R.H.LED (Lights when "relative humidity" is indicated.) | ⑩ Time base (Used for the graphic chart indication on the LCD.) |
| ⑤ COMP.LED (Lights when the compressor is running.) | |
| ⑥ DEFROST LED (Lights when the unit is under the defrosting operation.) | |

Function of operation key



●UNIT ON/OFF key

To start or to stop the unit operation.
The controller has a memory function.
If the power supply is cut off suddenly while the unit is on, and the power supply is then turned on again, the unit automatically starts the operation without pressing this key again. If the power supply is cut off while the unit is off, the unit does not start the operation unless this key is pressed.



●MODE key

To carry out the following control

- ① Generator set (=Power consumption control)
- ② Automatic pump down
- ③ Dehumidification set
- ④ Test set



●SET key

When the power supply is ON:

- ① Change operation mode from the CURRENT INDICATION MODE to the OPERATION SETTING MODE.
- ② Select the item to be set in the operation setting mode.

When the power supply is OFF:

- ① To change operation modes from the POWER OFF MODE to the BATTERY OPERATION MODE.



●SELECT key

Fresh air quantity (FA) can be displayed.

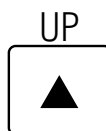

●UP key

To select the item to be set in the selected mode.



●DOWN key

To select the item to be set in the selected mode.



●ENTER/ESCAPE key

To determine the setting values or displayed contents in the selected mode.



CHART key (DISPLAY SELECT key)

If CHARTLESS Function is "ON", this key is effective.

To display logged temperature data in a simple graphic chart on the LCD, press this key when the display reads "set point temperature" or other data. When this is pressed once again, the display returns to "set point temperature" or other data again.

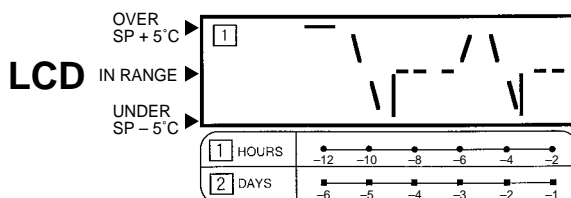





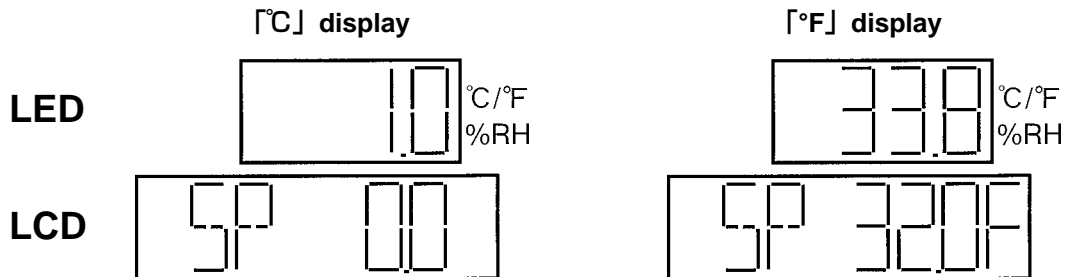

① Indicate the temperature data required to be converted into "°F" on the LED or the LCD.

Press the  key, then the temperature data displayed in "°C" is converted into "°F" for one minute.

※ If any other key is pressed during the "°F" indication, the display switches to "°C".



① Press the MANUAL DEFROST  key.

② Select "ON" indicated on the LED display using the  key or the  key, and press the  key to determine the setting, then the defrost operation starts.

※ Once defrosting operation starts, the operation mode is not changeable until the defrosting operation completes. If this key is pressed during the defrosting operation, it is ineffective.

※ Defrosting will not start when the evaporator outlet temperature is 20°C or higher or the inlet temperature is 5°C or higher.

3.2.2 Operation mode and control

Operation mode	Setting temperature	
	Chilled mode	Frozen mode
Operation procedure	Set the set point temperature at +30 to -5.0°C (+86 to +23.0°F).	Set the set point temperature at -5.1 to -30.0°C (+22.8 to -22°F).
Function	Chilled mode operation is initiated. Inside temperature is controlled proportionally in modulation by the supply air temperature sensor.	Frozen mode operation is initiated. Inside temperature is controlled by cycling ON/OFF of compressor by the return air temperature sensor.
	Evaporator fans run at high speed	Evaporator fans run at low speed

3.3 Operation procedure

3.3.1 Operation procedure flow chart

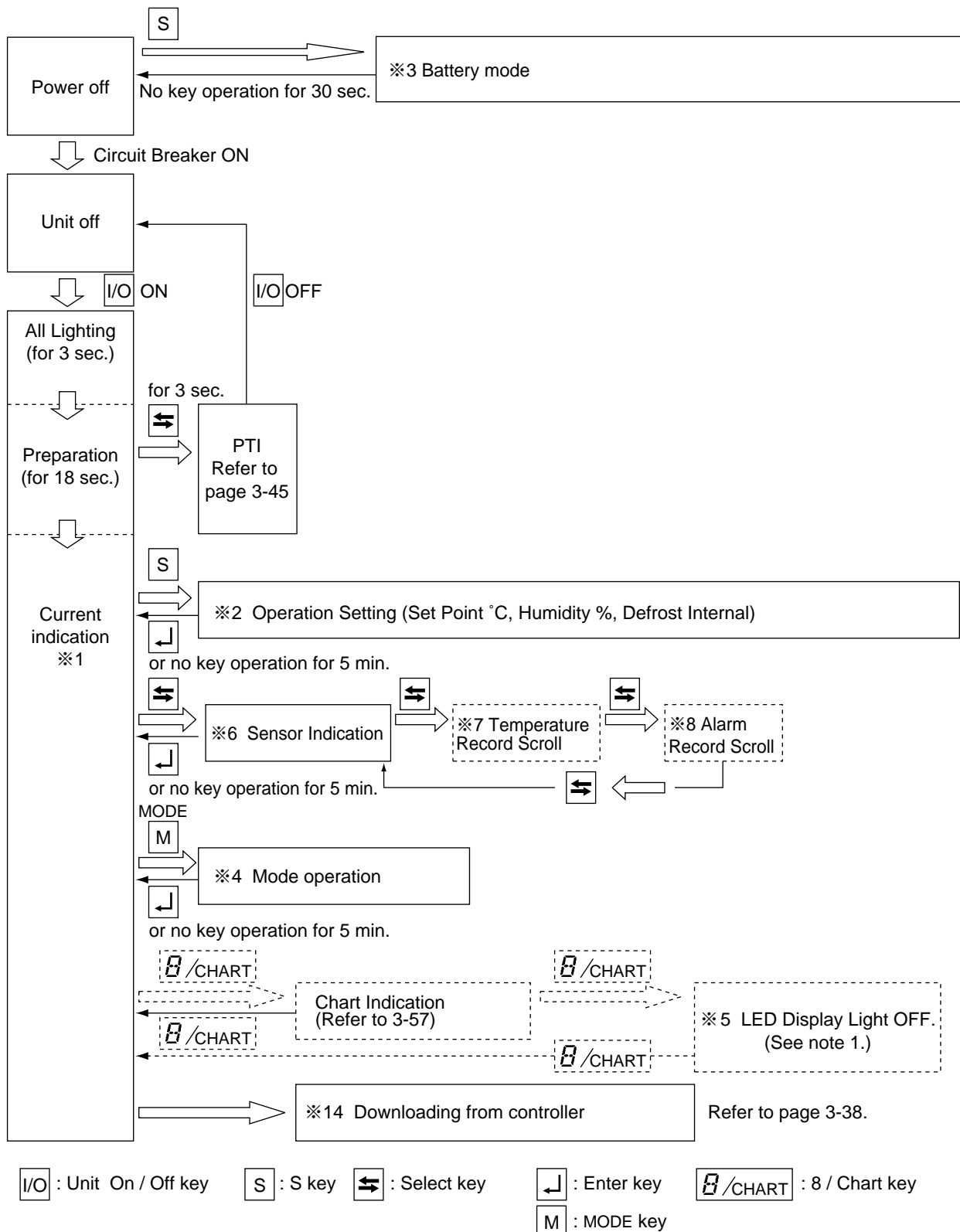

Note 1. ※5 activates when the "dISP" in ※11 is set to "ON" in controller initial setting in page 3-28.

Check on settings and operation conditions

※1. Current indication mode (indication of operation conditions)		
Indicates the unit operation conditions.	<ul style="list-style-type: none">●Supply air temperature (SS)●Return air temperature (RS)●Defrost interval●Alarm●Setting point humidity and humidity (OPTION)	P 3-9
※2. Operation setting mode		
Settings for cargo transportation	<ul style="list-style-type: none">●Temperature settings●Defrost interval settings●Humidity settings (optional)	P 3-10
※3. Battery mode (settings for operation conditions by using the battery)		
Setting can be executed when commercial power supply is not available.	<ul style="list-style-type: none">●Temperature display●Fresh air quantity (FA) display●Temperature settings●Humidity settings●Defrost interval settings●Unit ON/OFF setting	P 3-11
※4. Mode operation		
<ul style="list-style-type: none">●The maximum power consumption can be set.●The pump down can be executed automatically.●Dehumidification mode can be set.●Test mode can be set.		P 3-12

Indication of detailed data and alarm

※5. Sensor indication mode	<p>Each sensor value can be indicated.</p> <ul style="list-style-type: none"> ●Fresh air quantity (FA) ●High pressure (HPT) ●Low pressure (LPT) ●Total current (CT1) ●Compressor current (CT2) ●Voltage (PT1) ●Ambient temperature (AMBS) ●Evaporator inlet temperature (EIS) ●Evaporator outlet temperature (EOS) 	<ul style="list-style-type: none"> ●Discharge gas temperature (DCHS) ●Suction gas temperature (SGS) ●Modulating valve opening ●Electronic expansion valve opening ●Supply air temperature (SS) ●Return air temperature (RS) <div style="border: 1px solid black; padding: 2px; margin-top: 5px;"> <ul style="list-style-type: none"> ●Pulp temperature (USDA #1, #2, #3) ●Cargo temperature (CTS) ●Data recorder supply air temperature (DSS) ●Data recorder return air temperature (DRS) <p style="text-align: center;">[optional]</p> </div>	P 3-16
※6. Temperature record scroll function	<p>Temperature record of the control sensor can be indicated in the order (scroll indication) from the latest data.</p>	<ul style="list-style-type: none"> ●Chilled mode: Supply air temperature ●Frozen mode: Return air temperature (up to 7 days) 	P 3-19
※7. Alarm record scroll function	<p>Alarm record can be indicated in order (scroll indication) from the latest data.</p>	<ul style="list-style-type: none"> ●Alarm indication (up to 7 days) 	P 3-22

3.3.2 Mode operation procedure

1. CURRENT (Operation state) INDICATION MODE

Supply air temperature (SS), return air temperature (RS), defrosting interval, currently existing alarm, set point humidity, and humidity are indicated.

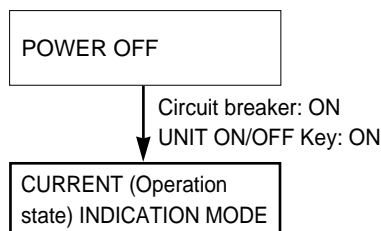

Turn on the circuit breaker and the UNIT ON/OFF key after turning the power supply on, then the display panel switches to the CURRENT INDICATION MODE. (Key operation in the CURRENT INDICATION MODE is possible after approx. 21 seconds from turning on the UNIT ON/OFF key.)

In the CURRENT INDICATION MODE, supply air temperature, return air temperature, defrosting interval, current alarm and current humidity (optional) are shown.

Select an item using the or key. The value of the selected item is indicated on the LED lamp, LED display and LCD display.

Indication item	LED lamp to be lit on	LED display	LCD display
	SUPPLY	Supply air temperature	Set point temperature
	RETURN	Return air temperature	Set point temperature
	Chilled mode: SUPPLY Frozen mode: RETURN	Chilled mode: SUPPLY air temperature Frozen mode: RETURN air temperature	Current defrosting interval setting
	ALARM	All the detected alarms codes or ("Good" if there is no detected alarm)	The total number of detected alarms
	R.H.	Value of humidity sensor	Set point humidity

Note 1) ●Each pressing of the down key, scrolls through the detected alarm codes in sequence when two or more alarm codes are displayed.
After indicating the last alarm, display goes to the next item.
The numerator of the LCD display stands for the current alarm, while the denominator stands for the number of alarm codes existing.

●To erase the d code or H code alarm, depress the key for 3 seconds while the code is displayed.

Note 2) ●The value of the humidity sensor is displayed only when the "Dehumidification Control on/off Setting" is set to "ON", otherwise this item is skipped and the next item is shown.

2. OPERATION SETTING MODE

Control temperature, defrosting interval, and control humidity (optional) can be set.

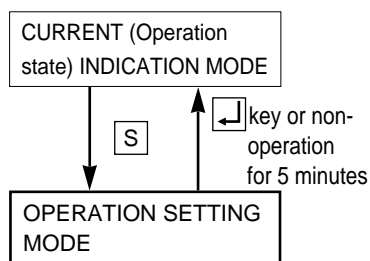

To change to the OPERATION SETTING MODE, press the **S** key while the unit is in the CURRENT INDICATION MODE.

In the OPERATION SETTING MODE, Control temperature, Control humidity (optional) and Defrosting interval can be set.

Select an item using the **S** key. The value of the selected item is indicated on the LED and LCD display.

Item	LED display	LED display	Setting method
CURRENT INDICATION MODE	–	–	–
CONTROL TEMPERATURE SETTING	Current setting temperature Note 2)	"SET-SPC" or "SET-SPF"	Change the value using the △ key or ▽ key. Press the ↵ key to determine the setting. Setting temperature range; –30 to 30°C.
CONTROL HUMIDITY SETTING (Note 1)	Current setting humidity	"SET-SHU"	Change the value using the △ key or ▽ key. Press the ↵ key to determine the setting. Setting humidity range: 60 to 95%RH
DEFROST INTERVAL SETTING	Current defrosting interval	"SET-dEF"	Select a defrost interval 99h, 24h, 12h, 9h, 6h, or 3h using △ key or ▽ key. Press the ↵ key to determine the setting. "On demand defrosting" is conducted when "99h" has been selected. (See page 2-14.)

Note 1) ● This indication appears only when the humidity control is set, otherwise this is skipped and the next item is shown.

Note 2) ● In case temperature is set in °C setting temperature can be set at interval of 0.1 °C.

In case temperature is set in °F, setting temperature should be the value converted into °F based on °C and rounded off the two decimal places.

3. BATTERY MODE

When commercial power is not available, the following functions are available by using the built-in wake up battery.

- Indication of inside supply air temperature (SS) and return air temperature (RS)
- Setting for control temperature, control humidity and defrost interval

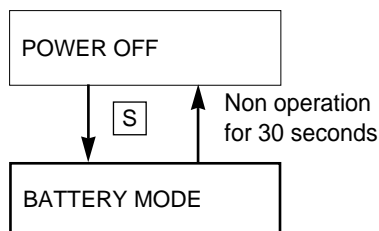

To change to the BATTERY MODE, press the **S** key while the unit is in the POWER OFF STATUS.

In the BATTERY MODE, return air temperature/supply air temperature can be indicated, Control temperature, Control humidity (optional), Defrosting interval and Unit ON/OFF key can be set.

Select an item using the **S** key. The value of the selected item is indicated on the LCD screen.

When no key operation is performed for 30 seconds in the BATTERY MODE, the battery mode turns off automatically off.

Item	LED display	LCD display	Setting method
POWER OFF	-	-	-
RETURN AIR TEMPERATURE DISPLAY	(Light off)	RS※※※.※C Note 1)	-
SUPPLY AIR TEMPERATURE DISPLAY	(Light off)	SS※※※.※C Note 1)	-
FRESH AIR QUANTITY DISPLAY	(Light off)	FA※※	-
CONTROL TEMPERATURE DISPLAY	(Light off)	SP※※※.※C	-
CONTROL TEMPERATURE SETTING	(Light off)	"SP C"	Change the value using the △ key or ▽ key. Press the ↵ key to determine the setting. Setting temperature range; -30 to +30°C.
CONTROL HUMIDITY SETTING	(Light off)	"SHU "	Change the value using the △ key or ▽ key. Press the ↵ key to determine the setting. Setting humidity range: 60 to 95%RH
DEFROST INTERVAL SETTING	(Light off)	"dEF H"	Select a defrost interval 99h, 24h,12h,9h,6h or 3h using the △ key or ▽ key. Press the ↵ key to determine the setting. "On demand defrosting" is conducted when "99h" has been selected. (See page 2-14.)
UNIT ON/OFF SETTING	(Light off)	"UNIT ON" or "UNIT OFF"	Change the value using the △ key or ▽ key. Press the ↵ key to determine the setting.

Note 1). The inside sensor temperature is indicated on the section of ※※※.※.

 CAUTION	<p>If no indication on the LCD panel is displayed by operating the key, it is supposed the wake-up battery is dead. Replace the battery.</p>
--	--

4. MODE OPERATION

Press the  key in current indication mode to go to MODE operation.

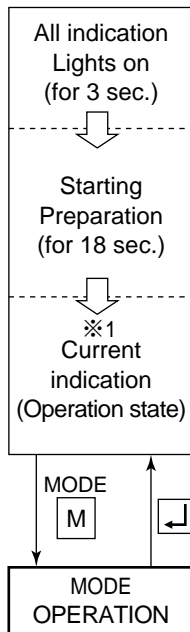

In mode operation, the following settings/operations are available.

1. Generator setting

Total power consumption can be reduced to desired Max setting for the specific generators set or power facilities.

The selections are "off (No limit)", "15" "14" "13" "12" "11" KVA.

2. Automatic pump down

Pump down can be executed automatically.

(Refer to "Automatic pump down" in 4.1.3)

3. Dehumidification mode setting

Dehumidification mode can be executed in this mode (Dehumidification mode control in 2.5.4).

When "Dehumidification" is set to "on", it is possible to change the following set from default.

① Inside humidity : 95% (Default) ~60% RH

4. Test mode

To make measurement of the power consumption and others of a unit, set the unit to dedicated test operation mode in which normal defrosting operation is disabled.

Setting item	LED panel	LCD panel	Setting method
<pre> graph TD A[Current indication mode] -- "MODE M" --> B[G-set operation Note 1)] B -- "MODE M" --> C[Automatic pump down operation] C -- "MODE M" --> D[Dehumidification] D -- "OFF MODE M" --> A D -- "ON MODE M" --> A </pre>	—	—	—
G-set operation Note 1)	OFF, 11, 12, 13, 14, 15 unit: kVA	G-SET	Select the energy saving set point by using or key, and press the key to determine the setting.
Automatic pump down operation	ON, OFF	P down	Select "ON" by using key and key, and press the key to determine the setting.
Dehumidification	ON/OFF	dHu	Select desired setting by or key, then press key.

Note 1) If the power supply is turned off in the G-set mode, the mode is cancelled 30 minutes from when power was lost.

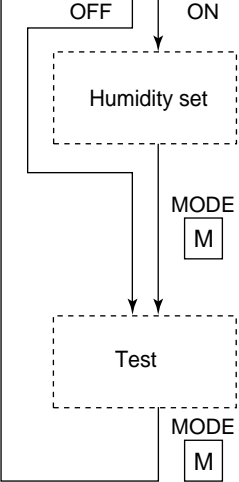
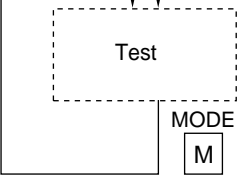
Setting item	LED panel	LCD panel	Setting method
	95% RH~30% RH	SET-SHU	Select desired setting by <input type="checkbox"/> key or <input type="checkbox"/> key, then press <input type="checkbox"/> key to determine.
	ON/OFF	TEST	Select desired setting by <input type="checkbox"/> key or <input type="checkbox"/> key, then press <input type="checkbox"/> key to determine.

5. LED display LIGHT-OFF MODE

The controller LED display is turned off with this mode.

※ Activation of the panel (LED) lighting off mode.

To activate the panel (LED) lighting off mode, set the LED lighting off function "dISP" in "11. Basic setting mode" to ON. Refer to page 3-27.

<Operation procedure>

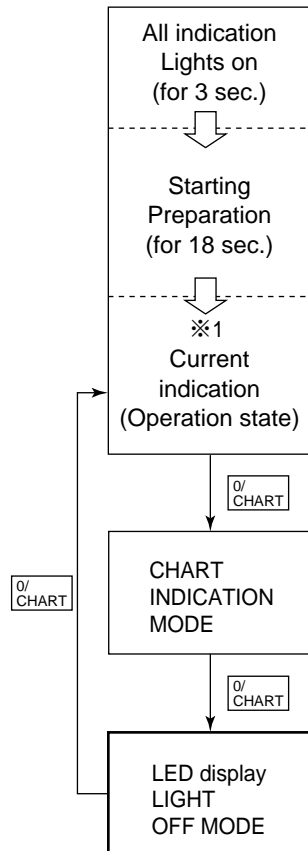

Push the  key twice during current indication mode to switch to the panel (LED) lighting off mode.
(When pushing the key once, the mode changes to chart indication mode.)

When the panel (LED) lighting off mode activates, the LED lighting is turned off and the LCD reads "dISPOFF".

※ Cancellation of panel (LED) lighting off mode.

When the  key is pushed again, it returns to current indication mode and LED turns ON.

6. SENSOR INDICATION MODE

Each sensor value, the modulating valve (MV) opening, the electronic expansion valve (EV) opening and the fresh air quantity (FA) can be checked. The following items are displayed:
 High pressure (HPT), low pressure (LPT), voltage (PT1), total current (CT1), compressor current (CT2), ambient temperature (AMBS), evaporator inlet temperature (EIS), evaporator outlet temperature (EOS), discharge gas temperature (DCHS), suction gas temperature (SGS), suction modulating valve opening, electronic expansion valve opening, supply air temperature (SS) (during PTI only), return air temperature (RS) (during PTI only), pulp temperature (USDA#1, UADA#2, USDA#3) (optional), cargo temperature (CTS) (optional), supply air temperature for data recorder (DSS) (optional), return air temperature for data recorder (DRS) (optional).

<Mode selection procedure>

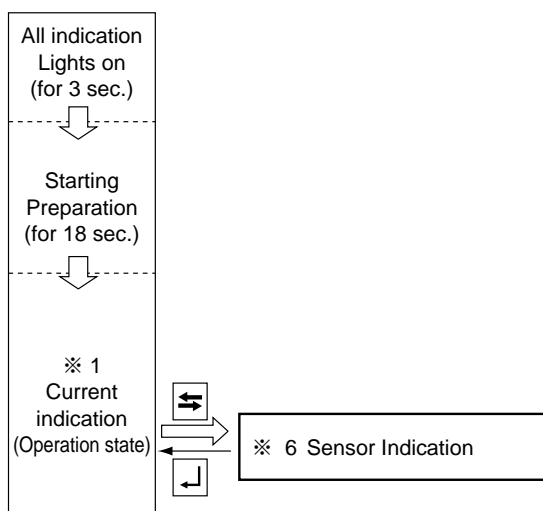

<Operation procedure>

Whenever the or key is pressed, the display changes.

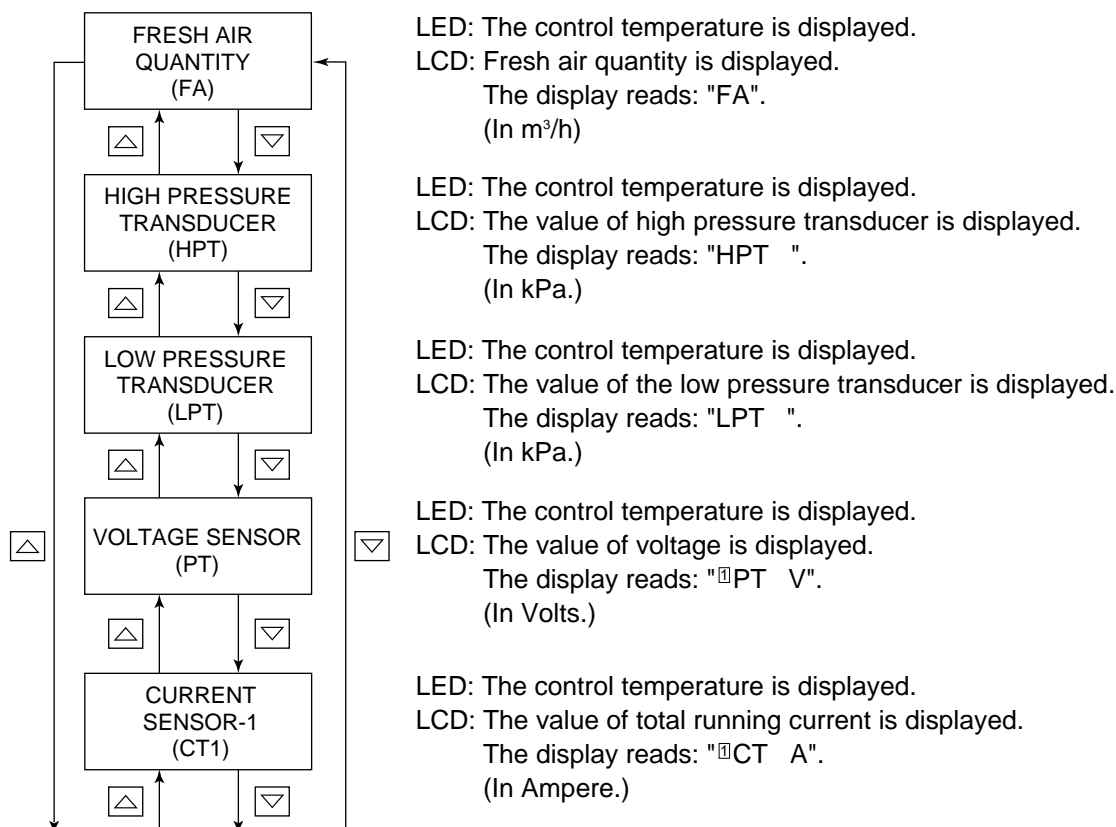

6. SENSOR INDICATION MODE (continued)

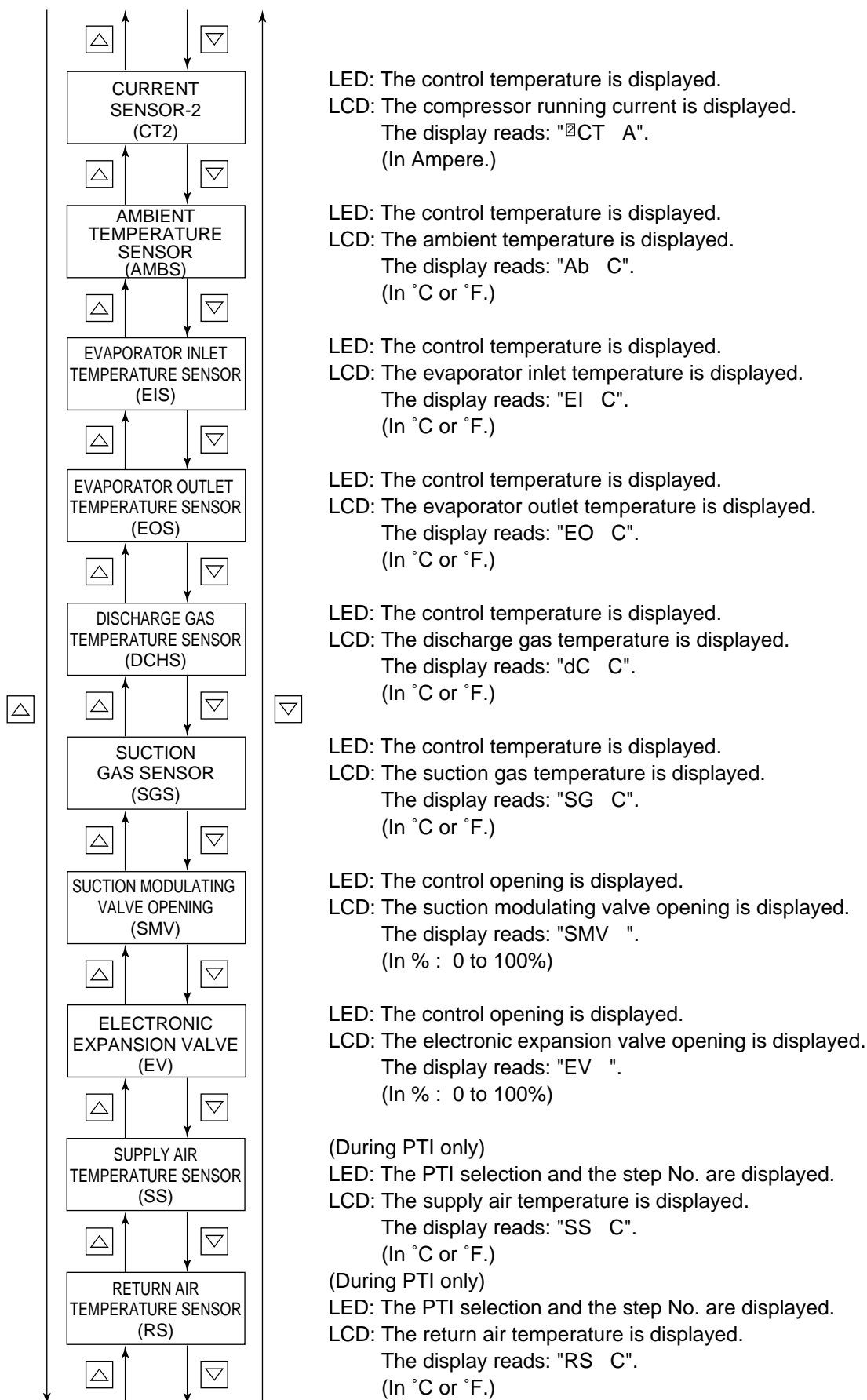

6. SENSOR INDICATION MODE (continued)

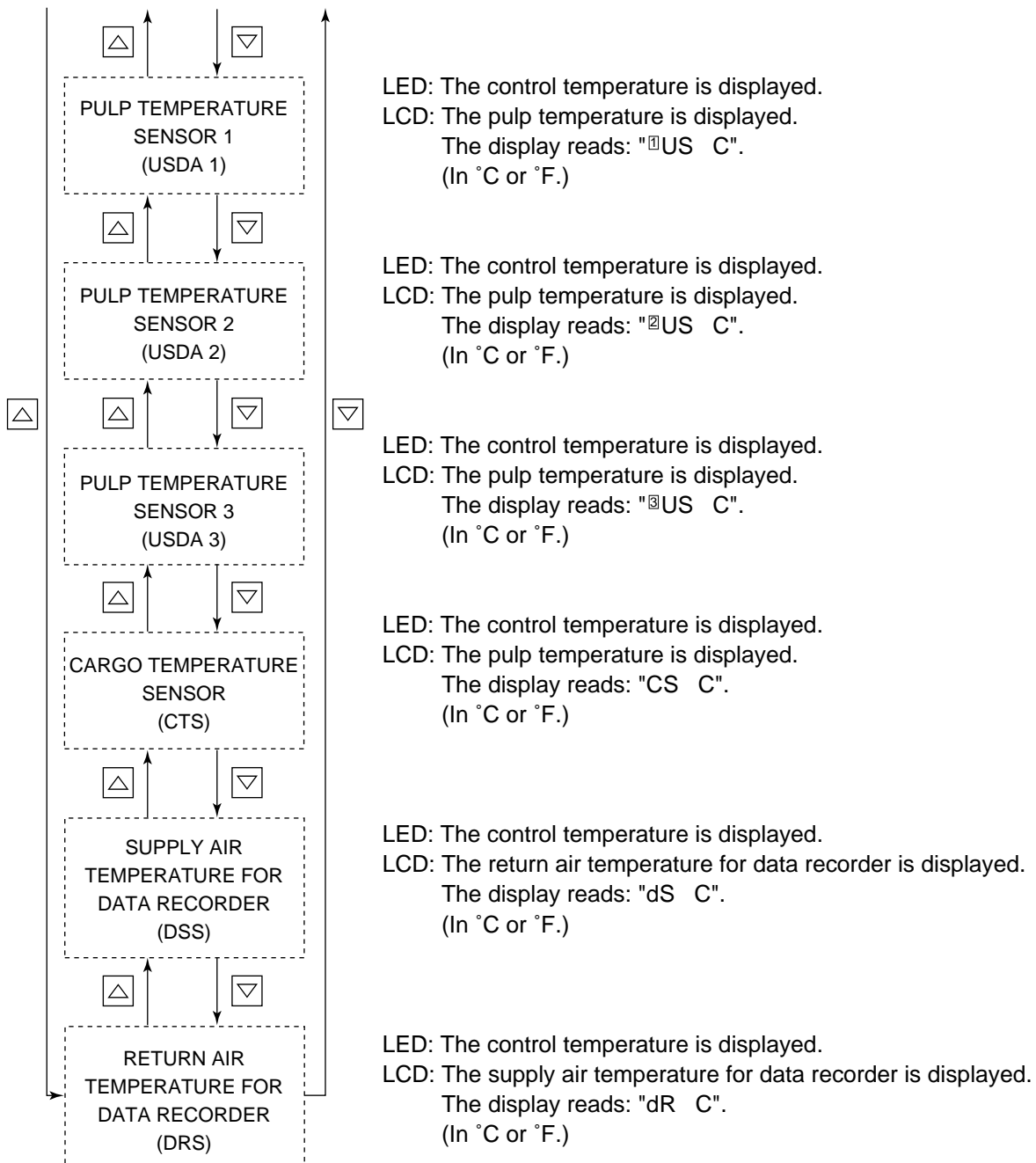

7. TEMPERATURE RECORD SCROLL MODE

The control sensor value record is shown in sequence (scroll) starting with the latest data. The latest control temperatures for a maximum of 7 days are displayed.

<Mode selection procedure>

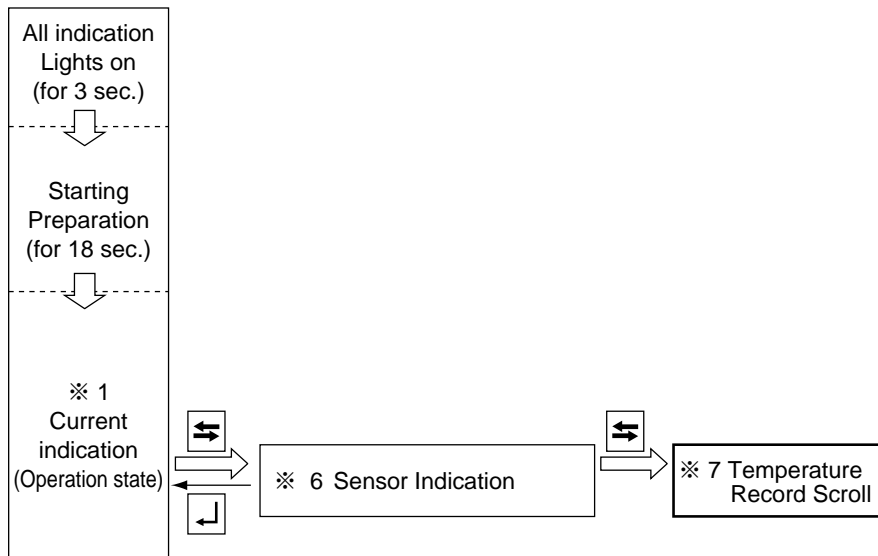

<Operation procedure>

The LED indicates the control temperature, and the LCD displays the data/time and the data record temperature in turn. (In the partial frozen mode and frozen mode, the return air temperature is the controlled temperature, and in the chilled mode, the supply air temperature is the control temperature.)

To pause the scrolling action, press the or key. To continue to the next temperature record manually, press the or key during the holding of indication, or to resume the automatically scroll function, do not press any key for 10 seconds. To see data beginning with start again, press and hold the key for 3 seconds.

To restore the current indication mode, press the key.

If key operation is not performed within 5 minutes, the current indication mode is resumed.





To go to the operation setting mode, press the key.

Temperature record scroll function

The control sensor value record for the last 7 days is displayed in sequence (scroll) beginning with the latest one and ending with oldest one, so that easy inspection of the previous operation data is enabled on board.

<Operation procedure>

The LED indicates the control temperature, and the LCD displays the data or time and the non-control temperature in turn. (In the partial frozen and frozen modes, return air temperature is the controlled temperature, and in the chilled mode, supply air temperature is the controlled temperature.)

To pause the scrolling action, press the  or  key. To advance to the next temperature record, press the  or  key again. If arrow key is not pressed for 10 seconds, the continuous scrolling action is resumed. To see data from the beginning, press and hold the  key for 3 seconds.

To restore the current indication mode screen, press the  key.

If key operation is not performed for 5 minutes, the current indication mode screen is resumed.

If the successive (scroll) screen is currently displayed, the current indication mode screen is resumed when 5 minutes elapses after indication ends.

To return to the operation setting mode, press the  key.



CAUTION

The displayed temperature is not the current instantaneous value but an average taken in a specific logging interval.

Therefore, the printed control temperature on the trip report (instantaneous value) printed with the aid of personal computer may differ from the sensor data of the chartless function.

This is not an error.

● Example of TEMPERATURE RECORD SCROLL INDICATION MODE

※ It is assumed that the control temperature is the supply air temperature (SS) and the logging interval is 1 hour, and the current date and time are June 27, 2002, 14:00.

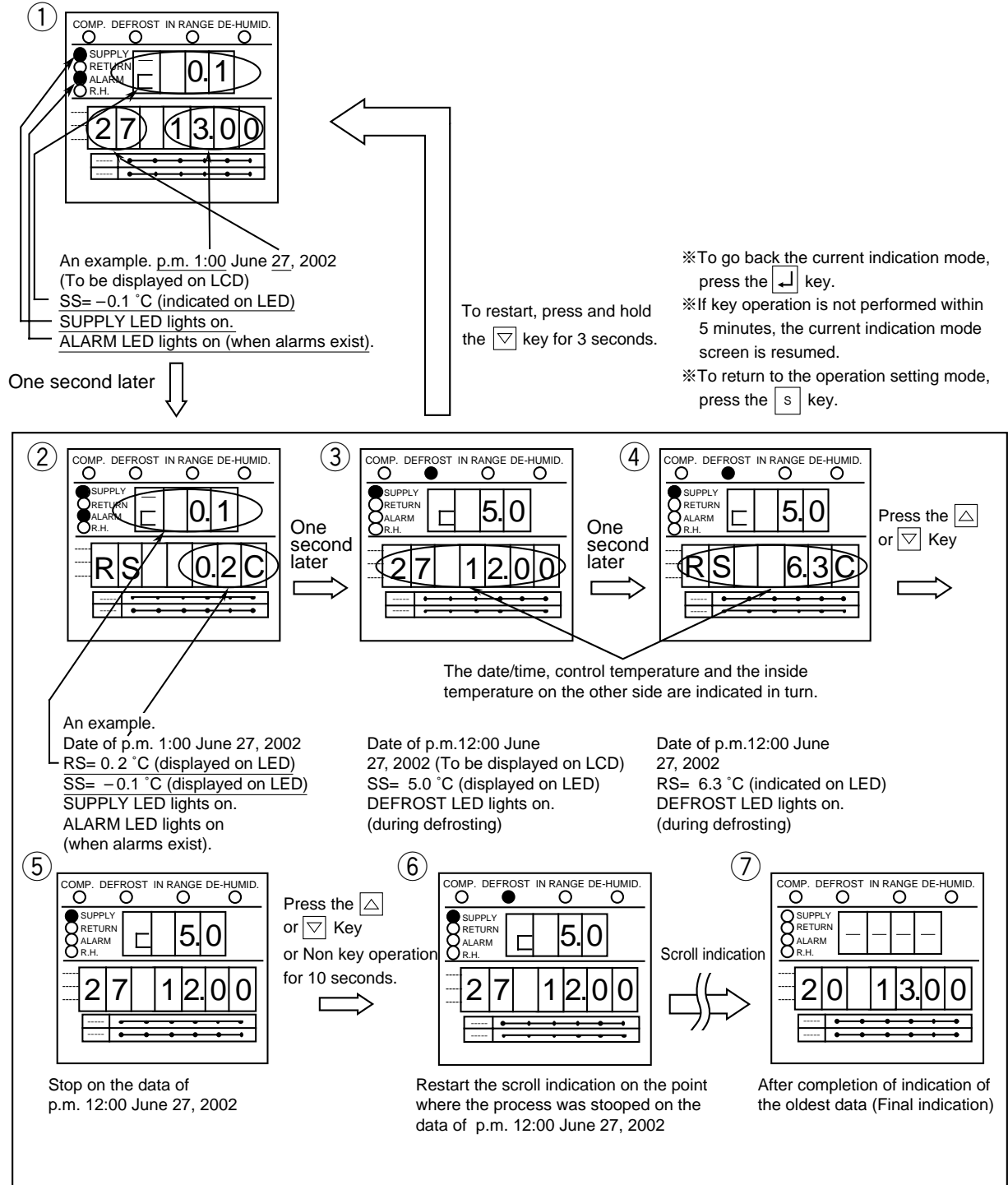

Note: "□" on the leftmost of the LED shows that the indication is of the temperature record scroll indication mode.

8. ALARM RECORD SCROLL MODE

The alarm record is shown in sequence (scroll) starting with the latest data. The latest alarms for a maximum of 7 days are displayed.

<Mode selection procedure>

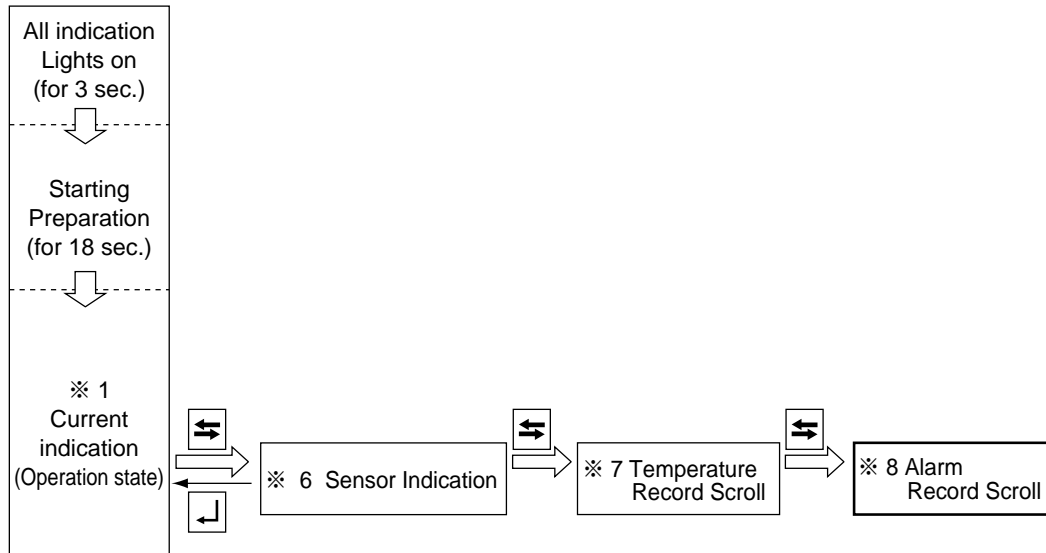

<Operation procedure>

The LED indicates the alarm codes and the LCD displays date and time.

To pause the scrolling action, press the or key. To continue to the next alarm record, press the or key during the holding of indication, or to resume the automatically scroll function, do not press any key for 10 seconds. To see data beginning with start again, press and hold the key for 3 seconds.

To restore the current indication mode, press the key.

If key operation is not performed within 5 minutes, the current indication mode is resumed.

To go to the operation setting mode, press the key.

Alarm record scroll function

The alarms detected over the last 7 days are displayed on the controller which scrolls through them at the rate of one sec/alarm.

< Operation procedure >

The LED indicates alarm codes, and the LCD displays date and time.

To pause the scrolling action, press the or key. To advance to the next alarm code detected, press the or key again. If arrow key is not pressed for 10 seconds, then the continuous scrolling action is resumed. To see data from the beginning, press and hold the key for 3 seconds.

To return to the current indication mode screen, press the key.

If key operation is not performed for 5 minutes, the current indication mode screen is resumed.

If the successive (scroll) screen is currently displayed, the current indication mode screen is resumed when 5 minutes elapses after the indication ends.

To return to the operation setting mode, press the key.

● Example of ALARM RECORD SCROLL INDICATION MODE

※ It is assumed that the current date and time are June 27, 2002, 14:00.

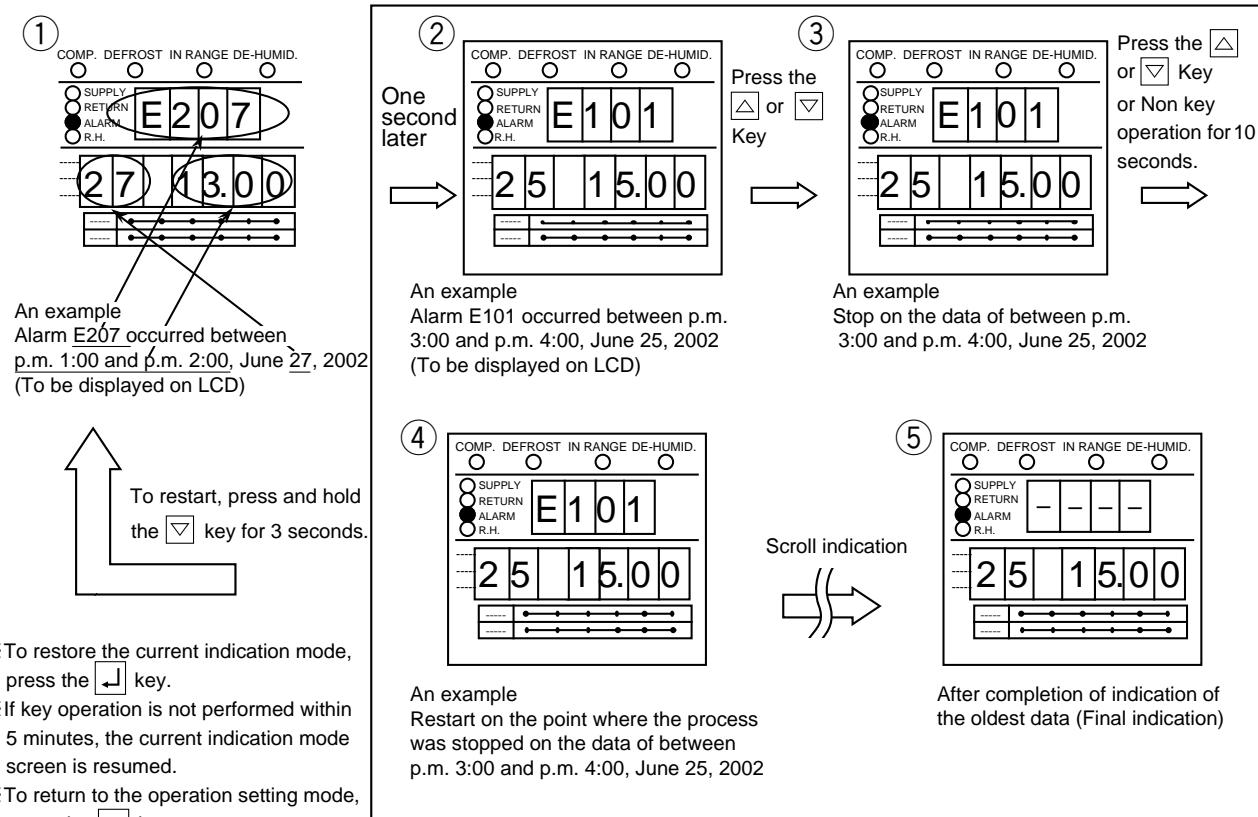

3.3.3 Setting flow chart

This configuration setting flow shall be utilized, when

CASE 1) USDA transportation setting is required (※10 Optional Function Setting)

CASE 2) Logging intervals shall be changed from default setting (60 min).
(※11 Basic Function Setting)

CASE 3) Setting of any H / d codes shall be changed from default. (※12 Optional Condition Setting)

CASE 4) Container ID shall to be subjected to change from another container for emergency use.
(※13 Container ID & Time Setting)

CASE 5) Controller is replaced to new one. (All setting in ※10~※13 shall be set.)

NOTE 1 : All initial settings are pre-set, when the unit is delivered.

(The initial setting for LXE10E-1 are underlined figures.)

2 : In CASE 5), the settings of "CHARTLS" and "USdA 1/2" shall be changed from default
(Default of spare controller : CHARTLS=Off, UsdA=1) to set for LXE10E-1 as below
underlined.

3 : In order to complete the setting change, CIRCUIT BREAKER shall be turned off

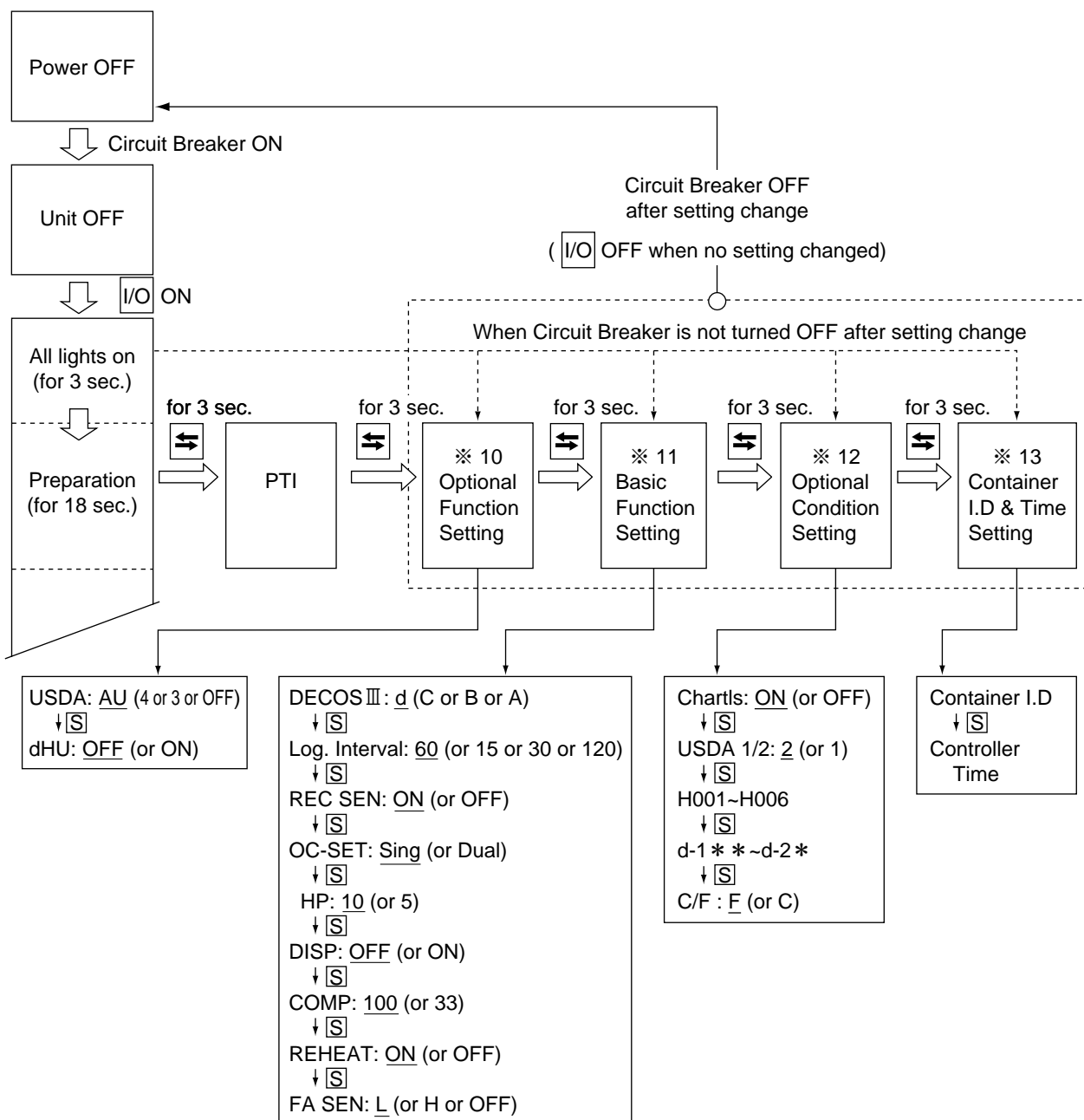

Controller initial setting

※10. Optional function mode		
●USDA sensor setting		P 3-26
●Dehumidification control on/off setting		
※11. Basic function setting mode		
●Controller type	●Logging interval	P 3-27
●Compressor unload	●Data recorder sensor on/off	P 3-28
●Reheat coil	●Power supply	
●FA H/L	●Compressor horse power	
	●Indication (LED section) light off function on/off	
※12. Optional condition setting mode		
●Chartless function setting	●H001	●d1--
●Type of USDA sensor	●H002	●d2--
●°C/°F set	●H003	●d3--
	●H004	●d-1-
	●H005	●d-2-
	●H006	
※13. Input data mode		
●Container I.D. (No.)		P 3-31
●Controller time		P 3-32

Personal computer and controller

※14. Controller software download mode		
Data logged in a personal computer and controller is exchangeable. For the details, refer to the "Operation manual for personal computer software".		P 3-32

10. OPTIONAL FUNCTION SETTING MODE

<Key operation to enter/exit>

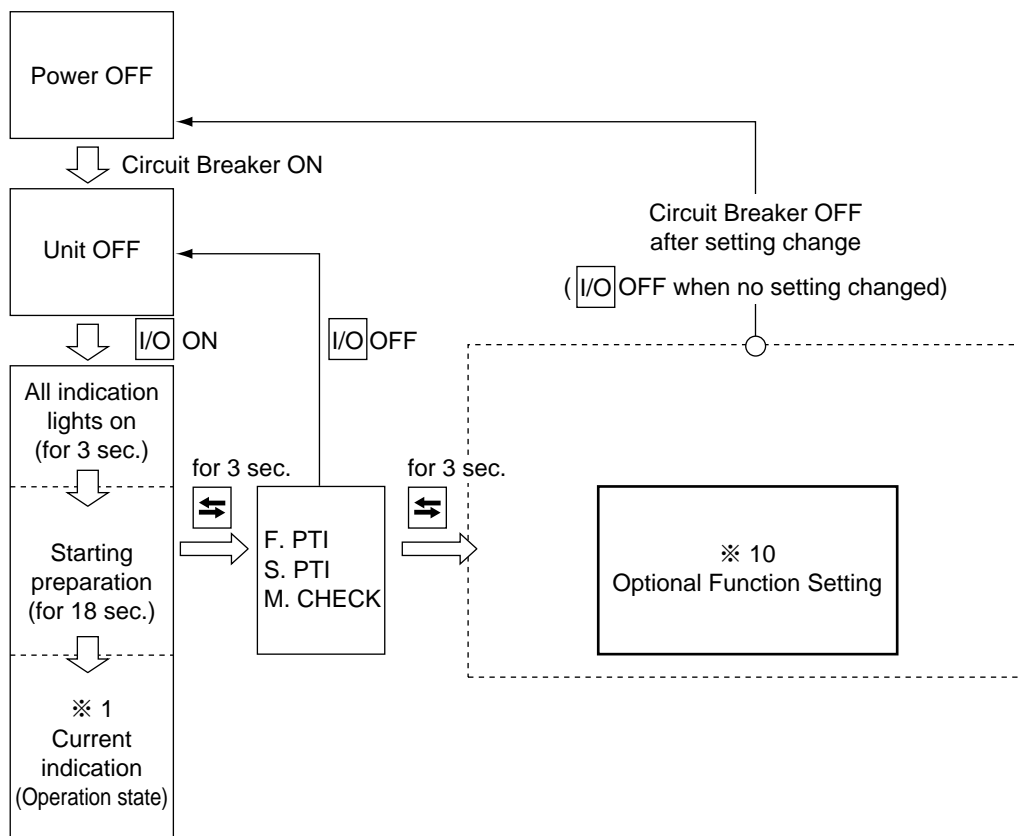

<Key operation in this mode>

Whenever the **[S]** key is pressed, the display changes.

Turn the power breaker OFF after the setting.

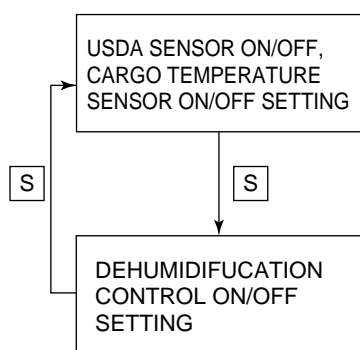

To set the USDA AUTO/ON/OFF and CARGO TEMPERATURE SENSOR ON/OFF:

Select "OFF (not in use)", "3 (3 USDA probes are in use)", "4 (3 USDA probes and 1 cargo temperature sensor are in use)", or "AU (AUTO setting)" on the LED while the LCD displays "USdA".

Whenever the **[△]** or **[▽]** key is pressed, the indication of "OFF" or "3" or "4" is changed.

Press the **[↵]** key to determine the setting.

Note: When two USDA probes are connected, the setting will be determined automatically to "3" (3 USDA probes are in use).

To set the DEHUMIDIFICATION CONTROL:

Select "ON" (conducting dehumidifying with humidity sensor) or "OFF" (conducting no dehumidifying) on the LED while the LCD indicates "dHU".

Whenever the **[△]** or **[▽]** key is pressed, the indication of "ON" or "OFF" is changed.

Press the **[↵]** key to determine the setting.

Note : This setting can be changed by **[M]** key. (Refer to page 3-12)

11. BASIC FUNCTION SETTING MODE

<Key operation to enter/exit>

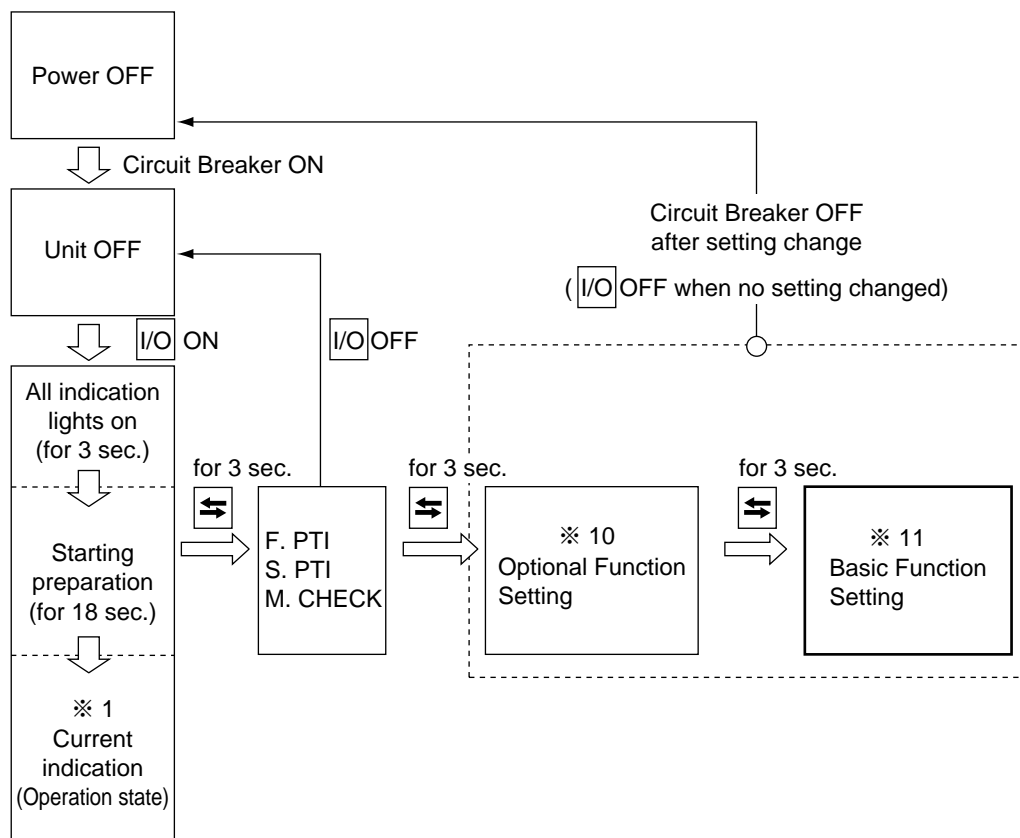

<Key operation in this mode>

Whenever the **[S]** key is pressed, the display changes.

Turn the power breaker OFF after the setting.

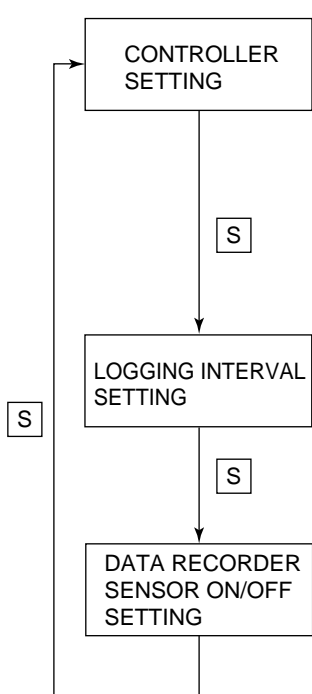

Select "A", "b" or "c" or "d" on the LED while the LCD displays "dECOS-3". Whenever the **[△]** or **[▽]** key is pressed, the indication of "A" or "b" or "c" or "d" is changed.

Press the **[↵]** key to determine the setting.

"A" represents "DECOS-III a", "b" represents "DECOS-III b", "c" represents "DECOS-III c" and "d" represents "DECOS-III d".

The unit is comes with the "DECOS-III d" additionally.

Select "d", and press **[↵]** key to determine the setting.

To set the logging interval:

Select "15", "30", "60" or "120" on the LED while the LCD displays "LOG INT". The unit is in minutes.

Whenever the **[△]** or **[▽]** key is pressed, the indication of "15" or "30" or "60" or "120" is changed.

Press the **[↵]** key to determine the setting.

To set the data recorder sensor ON/OFF:

Select "ON" (in use) or "OFF" (not in use) on the LED while the LCD displays "REC SEN".

Whenever the **[△]** or **[▽]** key is pressed, the indication of "ON" or "OFF" is changed. Press the **[↵]** key to determine the setting.

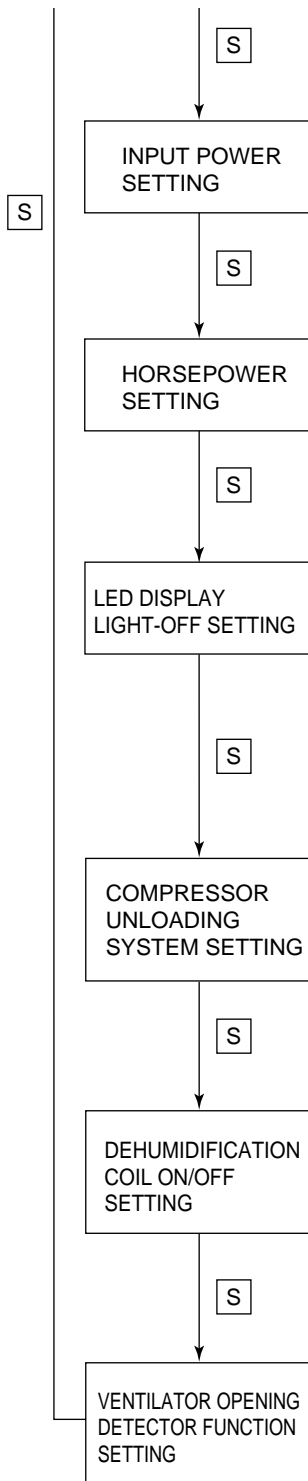

To set the power input:

Select "Sing" or "dUAL" on the LED when the LCD displays "OC-SET" .

Whenever the or key is pressed, the indication of "Sing" or "dUAL" is changed. Press the key to determine the setting.

For the unit, select "Sing", and press key to determine the setting.

To set the horse power setting:

Select "5" or "10" on the LED when the LCD displays "HP" (Horse power).

Whenever the or key is pressed, the indication of "5" or "10" is changed. Press the key to determine the setting.

To set the "panel (LED) lighting off" function ON/OFF:

Select "ON" (provided) or "OFF" (not provided) on the LED when the LCD displays "dISP" .

Whenever the or key is pressed, the indication of "ON" or "OFF" is changed. Press the key to determine the setting.

Note: When the 0/CHART key is pressed twice when the "panel (LED) lighting off" function is ON, the lights on the LED panel are turned off.

To set the compressor unloading system:

Select "33 (provided)" or "100 (not provided)" on the LED when the LCD displays "COMP".

Whenever the or key is pressed, the indication of "33" or "100" is changed.

Note: This "33" setting is applicable for LXE10D type only.

To set the dehumidification coil ON/OFF:

Select "ON (provided)" or "OFF (not provided)" on the LED when the LCD displays "REHEAT".

Whenever the or key is pressed, the indication of "ON" or "OFF" is changed. Press the key to determine the setting

Select "H (Upper)", L (Lower)" or "OFF (not provided)" on the LED when the LCD displays "FA SEN".

Whenever the or key is pressed, the indication of "H", "L" or "OFF" is changed. Press the key to determine the setting.

12. OPTIONAL CONDITION SETTING MODE

<Key operation to enter/exit>

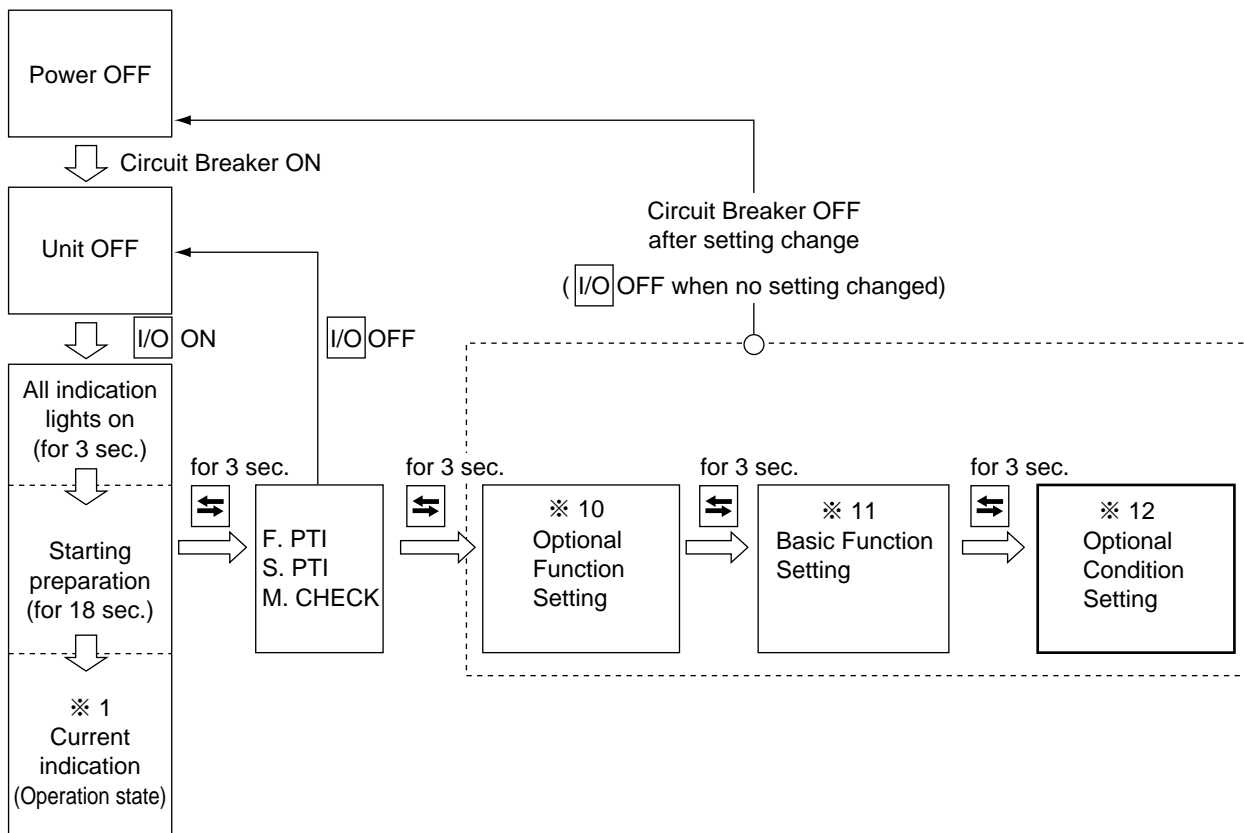

<Key operation in this mode>

Whenever the **[S]** key is pressed, the indication changes.

Turn the power breaker OFF after the setting.

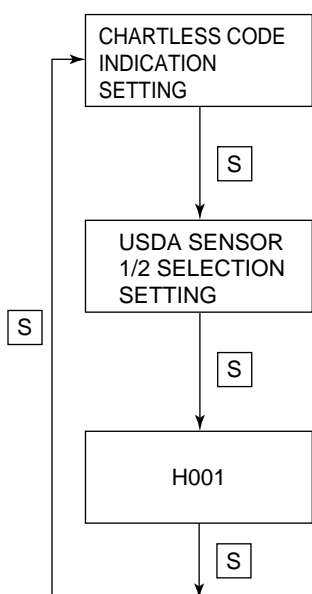

To set the chartless code (D code /H code):

Select "ON" (indication of D/H code) or "OFF" (no indication of D/H code) on the LED when the LCD displays "CHARTLS".

Whenever the **[△]** or **[▽]** key is pressed, the indication of "ON" or "OFF" is changed.

Press the **[↵]** key to determine the setting.

To set the USDA sensor selection:

Select "1" or "2" on the LED when the LCD displays "USdA1/2".

Whenever the **[△]** or **[▽]** key is pressed, the indication of "1" or "2" is changed.

Press the **[↵]** key to determine the setting.

H001 code is displayed when the control temperature does not lower by 3 °C or more for every 4 hours in pull-down operation.

Select "1" °C, "2" °C, "3" °C, "4" °C, "5" °C or "10" °C on the LED when the LCD displays "H001".

Whenever the **[△]** or **[▽]** key is pressed, the indication of the selection from "1" °C to "10" °C changes. Press the **[↵]** key to determine the setting.

Refer to page 3-61.

12. OPTIONAL CONDITION SETTING MODE (continued)

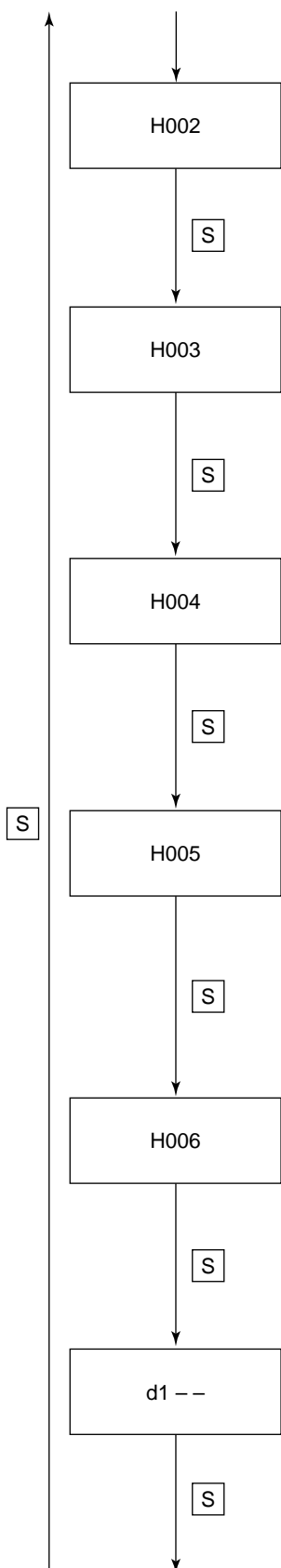

H002 code is displayed when the integrated time of Out-of "In-Range" reaches 2 hours.

Select "1"hour, "2"hours, "3"hours, "4"hours, "5"hours or "10"hours on the LED when the LCD displays "H002".

Whenever the or key is pressed, the indication of the selection from "1"hour to "10"hours changes. Press the key to determine the setting.

Refer to page 3-61.

H003 code is displayed when the integrated time "below SP-1 °C" reaches 2 hours.

Select "1"hour, "2"hours, "3"hours, "4"hours, "5"hours or "10"hours on the LED when the LCD displays "H003".

Whenever the or key is pressed, the indication of the selection from "1"hour to "10"hours changes. Press the key to determine the setting.

Refer to page 3-61.

H004 code is displayed when the integrated time of state "below SP-2 °C" reaches one hour.

Select "1"hour, "2"hours, "3"hours, "4"hours, "5"hours or "10"hours on the LED when the LCD displays "H004".

Whenever the or key is pressed, the indication of the selection from "1"hour to "10"hours changes. Press the key to determine the setting.

Refer to page 3-61.

H005 code is displayed when the controlled temperature is Out-of "In-Range", and defrosting was performed successively three times while the controlled temperature does not return to In-Range.

Select "1"time, "2"times, "3"times, "4"times, "5"times or "10"times on the LED when the LCD displays "H005".

Whenever the or key is pressed, the indication of the selection from "1" time to "10"times changes. Press the key to determine the setting.

Refer to page 3-62.

H006 code is displayed when the integrated time with a difference of 2 °C or more between control sensor data and record sensor data reaches one hour.

Select "1"hour, "2"hours, "3"hours, "4"hours, "5"hours or "10"hours on the LED when the LCD displays "H006".

Whenever the or key is pressed, the indication of the selection from "1"hour to "10"hours changes. Press the key to determine the setting.

Refer to page 3-62.

"d1 --" message displays the total time in hours, that the temperature was above set point +1°C.

The code will be displayed after the selected time which can be set to: "1"hour, "2"hours, "3"hours, "4"hours, "5"hours, or "10"hours. When the total time above set point +1°C reaches "1"hour, the code "d101" will be displayed.

Whenever the or key is pressed, the selection from "1"hour to "10"hours changes. Press the key to determine the setting.

Refer to page 3-63.

12. OPTIONAL CONDITION SETTING MODE (continued)

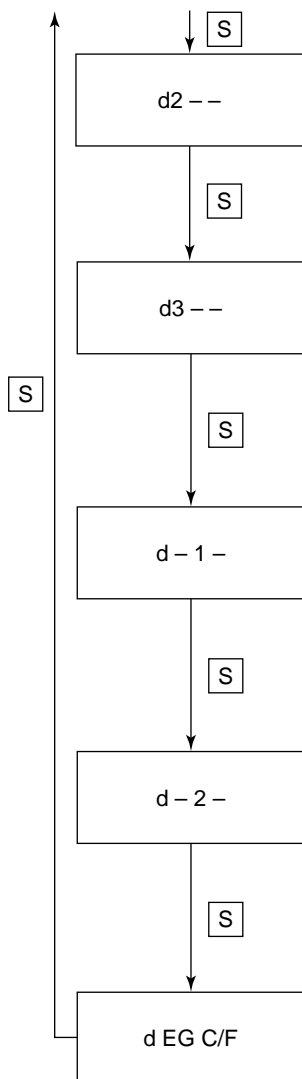

"d2 --" message displays the total time in hours, that the temperature was above set point +2°C. The code will be displayed after the selected time which can be set to: "1"hour, "2"hours, "3"hours, "4"hours, "5"hours, or "10"hours. When the total time above set point +2°C reaches "1"hour, the code "d101" will be displayed.

Whenever the or key is pressed, the selection from "1"hour to "10"hours changes. Press the key to determine the setting. Refer to page 3-63.

"d3 --" message displays the total time in hours, that the temperature was above set point +3°C. The code will be displayed after the selected time which can be set to: "1"hour, "2"hours, "3"hours, "4"hours, "5"hours, or "10"hours. When the total time above set point +3°C reaches "1"hour, the code "d101" will be displayed.

Whenever the or key is pressed, the selection from "1"hour to "10"hours changes. Press the key to determine the setting. Refer to page 3-63.

"d - 1 -" message displays the total time in hours, that the temperature was below set point -1°C. The code will be displayed after the selected time which can be set to: "1"hour, "2"hours, "3"hours, "4"hours, "5"hours, or "10"hours. When the total time below set point -1°C reaches "1"hour, the code "d101" will be displayed.

Whenever the or key is pressed, the selection from "1"hour to "10"hours changes. Press the key to determine the setting. Refer to page 3-63.

"d - 2 -" message displays the total time in hours, that the temperature was below set point -2°C. The code will be displayed after the selected time which can be set to: "1"hour, "2"hours, "3"hours, "4"hours, "5"hours, or "10"hours. When the total time below set point -2°C reaches "1"hour, the code "d101" will be displayed.

Whenever the or key is pressed, the selection from "1"hour to "10"hours changes. Press the key to determine the setting. Refer to page 3-63.

With dEG C/F mode, can be selected.

Select "F" or "C" on the LED when the LCD displays "d EG C/F".

Whenever the or key is pressed, the indication of the selection "F" or "C" changes. Press the key to determine the selection. "C" stands for °C/kPa while "F" for °F/PSI.

13. INPUT DATA MODE

<Key operation to enter/exit>

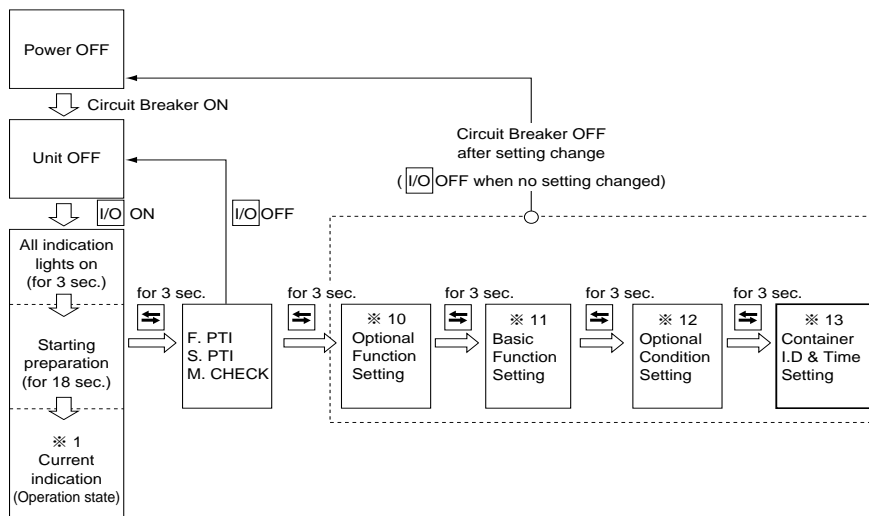

<Key operation in this mode>

Whenever the **[S]** key is pressed, the indication changes.

Turn OFF the power breaker to confirm the setting.

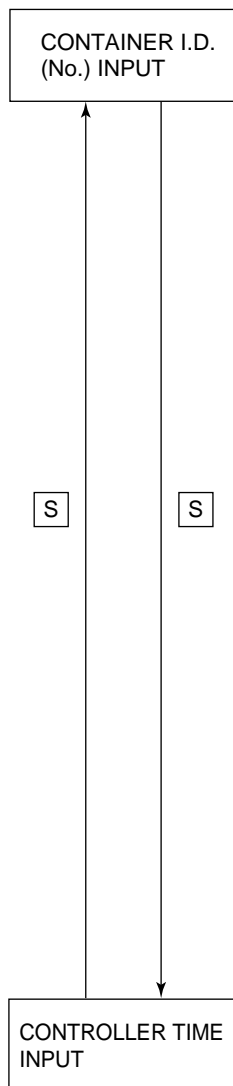

To input the container I.D. (No.):

Press the **[↵]** key when the LCD displays "SET I.d", then display "i.d.-C" (name of shipping company input with alphabetical character) or "i.d.-n" (number input with numerical character) on the LED by using **[△]** or **[▽]** key.

To input the shipping company name (alphabet):

Press the **[↵]** key when the LED displays "i.d.-C", then the leftmost digit on LCD flashes. Select the alphabet to be input using the **[△]** or **[▽]** key, and press the **[↵]** key, then the flashing digit shifts to the right.

Carry on the same procedure until the 4 letters are input, then press the **[↵]** key to determine the input. Once determined, the input letters will flash.

To input the numbers (numeral):

Press the **[↵]** key when the LED displays "i.d.-n", then the leftmost digit on LCD flashes. Select the number to be input by using the **[△]** or **[▽]** key, and press the **[↵]** key, then the flashing digit shifts to the right.

Carry on the same procedure until the 7 numbers are input, then press the **[↵]** key to determine the input.

Once determined, the input numbers will flash.

Note) Determining the last-digit figure of the container number by using the **[↵]** key will automatically check for the last-digit figure. If the figure is correct, the input will end. If it is wrong, the unit will return to the input screen of shipping company name.

However, only when the last-digit figure flashes, press and hold the **[↵]** key for a period of 3 seconds, thus making it possible to end the input without checking.

To set the control time:

Press the **[↵]** key when the LCD displays "SET TIME", then the LCD displays "YEAR" and the LED shows the year currently set in the controller. Change the setting year by using the **[△]** or **[▽]** key, then press the **[↵]** key to determine the setting.

Then, the LCD displays "MONTH" and the LED displays the month currently set in the controller. Change the setting month by using the **[△]** or **[▽]** key, then press the key to determine the setting.

Set day, time and minute by the same procedure.

Enter the day, hour or minute when "DAY", "HOUR" or "MINUTE" is displayed on LCD respectively.

If the power circuit breaker (CB) is not turned off, the new setting will not be recognized.

14. CONTROLLER SOFTWARE DOWNLOAD MODE

The data on personal computer and a controller are interchanged in this mode.

For details, see the Operation Manual For Personal computer software.

Downloading is possible even in "3. BATTERY MODE". page 3-11.

3.4 Alarm display and back-up function

3.4.1 Alarm list

Alarm grouping	Alarm code	Alarm content	Action with alarm	
Permanent stop	F101	HPS activated within 30 seconds after operation start or protection device activated 5 times at start-up operation or Fuse 1 brown (Refer Page 7-8).	Unit stops	
	F109	Low- pressure drops to-85kPa or lower within 2 seconds after operation start.	Unit stops	
	F111	HPS does not activate when it reaches to the set value.	Unit stops	
	F301	Temperature setting required (SRAM failure)	Unit stops	
	F401	Return/Supply air sensor malfunction (at chilled mode)	Unit stops	
	F403	Return/Supply air sensor malfunction (at partial frozen mode)	Unit stops	
	F603	Suction modulating valve (SMV) does not fully close contrary to the designation or initial setting of the controller is wrong.	Unit stops	
	F701	Abnormal high voltage	Unit stops	
	F705	S phase became open phase	Unit stops	
F803	Abnormalities, which make it impossible to continue operation (Note2.)	Unit stops		
Display alone or restartable alarm	Protection device activation	E101	High-pressure switch activated during normal operation.	Restart after 3-minute Restart after 3-minute Restart after 3-minute Restart after 3-minute If this error occurs two times, F803 error will be detected to stop the unit. Restart after 3-minute
		E103	CTP or electronic OC activated during normal operation.	
		E105	Micro processor OC activated during normal operation.	
		E107	DCHS became abnormal high temperature during operation. In the event the refrigerant circulation rate is low, the unit will stand by for three minutes to restart then.	
		E109	Low pressure drops to-90kPa or lower for 2 seconds or longer successively during normal operation.	
	Control error	E201	Pump down is not completed within 90 seconds.	Only alarm display Restart after 3-minutes
		E203	Overcool protection activates in the chilled or partial frozen mode. (Control temperature \leq SP-3°C or for 3 minutes)	
		E207	Defrosting is not completed within 90 minutes	
	Printed-circuit board failure	E303	Humidity setting required (SRAM failure)	Only alarm display Only alarm display Only alarm display Only alarm display Restart after 3-minutes
		E305	Defrost timer setting required (SRAM failure)	
		E307	Calendar setting required (SRAM failure)	
		E311	Trip-start setting required (SRAM failure)	
		E315	PT/CT board failure	
	Sensor alarm	E401	Supply air temperature sensor (SS) malfunction	Back-up operation Back-up operation Back-up operation Back-up operation Only alarm display Back-up operation Back-up operation Back-up operation Only alarm display Back-up operation Back-up operation Only alarm display Only alarm display Restart after 3-minutes Only alarm display Only alarm display Only alarm display Only alarm display
		E402	Data recorder supply air temperature sensor (DSS) malfunction	
		E403	Return air temperature sensor (RS) malfunction	
		E404	Data recorder return air temperature sensor (DRS) malfunction	
		E405	Discharge air temperature sensor (DCHS) malfunction	
		E406	Suction gas temperature sensor (SGS) malfunction	
		E407	Evaporator inlet temperature sensor (EIS) malfunction	
		E409	Evaporator outlet sensor (EOS) malfunction	
		E411	Ambient sensor (AMBS) malfunction	
		E413	Low pressure transducer (LPT) malfunction	
		E415	High pressure transducer (HPT) malfunction	
		E417	Voltage sensor (PT1) malfunction	
		E421	Current sensor (CT1) malfunction	
		E423	Current sensor (CT2) malfunction	
E425		Pulp temperature sensor (USDA1) malfunction		
E427		Pulp temperature sensor (USDA2) malfunction		
E429		Pulp temperature sensor (USDA3) malfunction		
E431	Humidity sensor (HuS) malfunction			
E433	Cargo temperature sensor (CTS) or box temperature sensor (CBS) malfunction			
E805	Ventilator opening detector error	Only alarm display		
Electronic functional part alarm	E603	Suction modulating valve (SMV) malfunction or driver malfunction	Back-up operation	
	E607	MDS (sheet key) malfunction	Only alarm display	
Power supply alarm	E707	Momentary power failure	Restart after 3-minutes	
Operation alarm	E807	FA open error when lower ventilator is opened during frozen operation.	Only alarm displayed	

- Note 1) The alarm LED does not blink when E code alarm is generated.
To check if any alarm generates, use alarm indication function in the section "1. Current indication mode" of "3.3.2 Mode operation procedure."
- 2) In the event error E101, E103, E107, or E109 occurs 10 times, the system will go to 4-hour standby mode.
- 3) In case of sensor malfunction, the judgment for sensor malfunction does not perform for 3 minutes before the pressure or temperature reaches to the specified value.

3.4.2 Back-up operation at sensor malfunction

Sensor malfunction		Mode	Back-up content
SS	Supply air temperature sensor	Chilled	The same control is executed by using DSS (optional). In case of DSS malfunction, [RS-2.0°C] is used for control. When DSS and RS are faulty, the unit should be stopped.
		Frozen Defrost	No influence (continuous operation)
RS	Return air temperature sensor	Chilled Defrost	No influence (continuous operation)
		Defrosting	The same control is executed by using DRS (optional).
AMBS	Ambient temperature sensor	All modes	Continuous operation
DCHS	Discharge gas temperature sensor	Chilled	Continuous operation
		Frozen	Continuous operation
		Defrosting	
EIS	Evaporator inlet temperature sensor	Chilled	Continuous operation
		Frozen	See the next page
		Defrosting	No influence (continuous operation)
EOS	Evaporator outlet temperature sensor	Chilled	Continuous operation
		Frozen	See the next page
		Defrosting	Defrosting start-up: Always permissible Defrosting termination: The 90 minute timer count-up or when EIS>90°C or RS>set point
SGS	Suction gas temperature sensor	Chilled	Continuous operation
		Frozen	See the next page
		Defrosting	No influence (continuous operation)
HPT	High pressure transducer	Chilled Frozen	Continuous operation
		Defrosting	Refrigerant charge: No influence Refrigerant release: LPT is used for releasing.
LPT	Low pressure transducer	Chilled Frozen	Continuous operation
		Defrosting	Refrigerant charge: HPT is used for charging Pump down: Pump down operation is not conducted
HPS	High pressure switch	All modes	No back-up operation
WPS	Pressure switch for water	All modes	No back-up operation
CTP	Compressor thermal protector	All modes	No back-up operation

●Back-up for temperature sensors (EIS, EOS, SGS) at frozen mode (superheat control)

No.	Evaporator inlet sensor EIS	Evaporator outlet sensor EOS	Compressor suction gas sensor SGS	Back-up operation
1	Normal	Normal	Normal	superheat control
2	Normal	Normal	Abnormal	superheat control
3	Normal	Abnormal	Normal	Liquid refrigerant back prevention to compressor by EIS and SGS
4	Normal	Abnormal	Abnormal	Expansion valve fixed opening rate control
5	Abnormal	Normal	Normal	Liquid refrigerant back prevention to compressor by EOS and SGS
6	Abnormal	Normal	Abnormal	Expansion valve fixed opening rate control
7	Abnormal	Abnormal	Normal	Expansion valve fixed opening rate control
8	Abnormal	Abnormal	Abnormal	Expansion valve fixed opening rate control

3.5 Battery

3.5.1 Specifications

DECOS III d controller can use Rechargeable battery. It is not possible to exchange the type of battery afterwards.

The battery is positioned on CPU & I/O box in controller box.

Rechargeable battery: DAIKIN original rechargeable battery, type: 6N-600AA-2 (Red wire is (+), Black wire is (-))

3.5.2 Function

This battery is used without main power supply for the following functions.

	1) Display wake up	2) USDA data log	3) Trip data log
Rechargeable battery	○	○	○

○ : Available — : Not available

1) Display wake up (Refer to section 3.3.2) page 3-11.

Setting/Display the following items on the LCD display.

<Display>

Temperature on the return air sensor

Temperature on the supply air sensor

<Setting change>

Inside temperature, defrosting interval, dehumidifying set (Optional), Unit ON/OFF

2) USDA data log

USDA sensors data log every 1 hour

Note) When the Alkaline battery is equipped, it must be replaced for a new every PTI, when USDA is used.

3) Trip data log

Trip data; Setting point, Supply air, Return air, Humidity and time is logged every 1 hour after power off until battery run out. (Min. 3 days)

3.5.3 Battery check

Dry battery: Press key to confirm the Battery mode workable.

When the power is disconnected.

Rechargeable battery: Press "Battery check meter"

Green: Operatable

Red: Replace battery

3.5.4 Battery replacement (Rechargeable battery)

First, turn off the power supply to the refrigeration unit. Then, detach the cover of battery and replace the battery. At this time, be sure to use the specified type of battery.

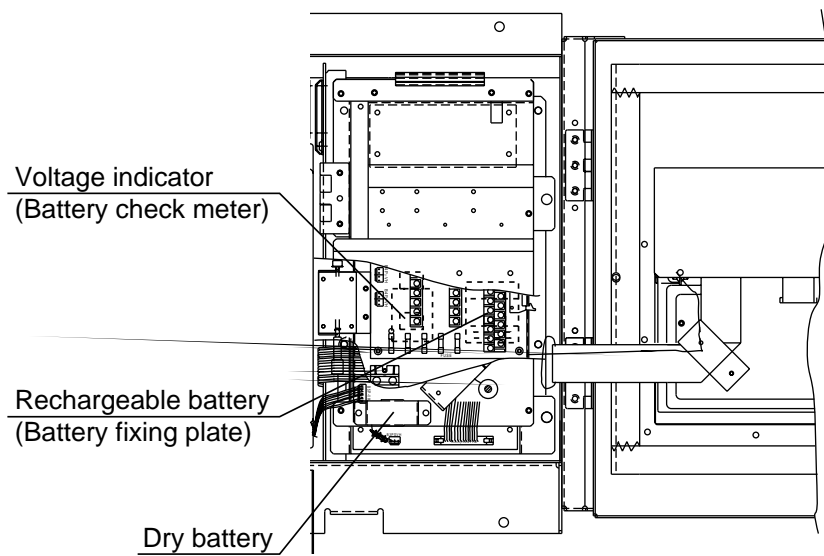

CAUTION

- A Ni-Cd battery is used. Remove the used battery from the refrigeration unit, and then safely collect and dispose it.
- Before scrapping the refrigeration unit, be sure to remove the battery from the unit.

3.6 Information interchange with personal computer

The electronic controller DECOS III d has a internal memory function to record the set point temperature, inside temperature, operation mode, occurrence alarm and the report of automatic PTI during transportation in addition to the normal operation control.

Also users can retrieve the logging data and operations condition of the unit and save the information on a personal computer through the serial communication port (personal computer receptacle) provided on the controller front panel. The retrieved data are useful to analyze any problems that occurred during transportation and to prepare various kinds of reports.

Moreover, users can up-load the information such as the container No., cargo name, destination and other information from their personal computer to the controller.

Refer to the Operation Manual for Personal Computer Software for detail.

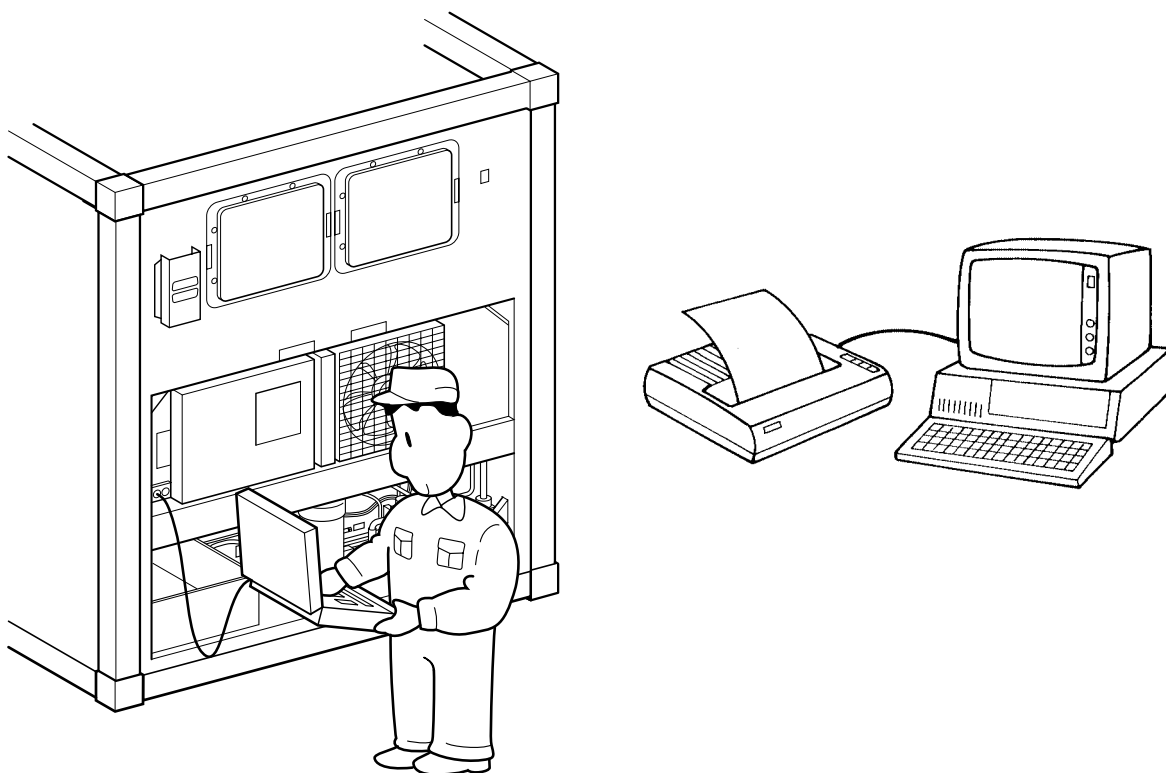

3.6.1 Data logging

The data logging function is to store operation data which is generated during navigation. There are seven kinds of logging data.

As to Tripdata, its logging interval can select from 15, 30, 60 (default) and 120 minutes.

※When F. PTI is executed, the logging interval become default (Refer to 3.9.2.3)

※Controller has Max. 2 years capacity at 60 min log interval.

	Data name	Logging data
1	ID data	<ul style="list-style-type: none"> ● Container No. ● Departure port ● Set point temperature ● Set point ventilation flow rate ● Set point humidity ● Comment ● Loading date ● Load ● Transit place ● Final destination ● Navigation No.
2	Trip data	<ul style="list-style-type: none"> ● Operation mode ● Supply air temperature (SS) ● Return air temperature (RS) ● Inside humidity (optional) ● Ambient temperature (AMBS) ● Set point temperature ● Set point humidity (optional) ● Data recorder sensor temperature (DSS/DRS) (optional)
3	Alarm	<ul style="list-style-type: none"> ● Alarm output date/time ● Alarm code
4	PTI	<ul style="list-style-type: none"> ● SHORT PTI ● FULL PTI
5	USDA	<ul style="list-style-type: none"> ● Pulp sensor temperature (USDA #1 to #3) ● Date/time ● Logging interval is 1 hour.
6	Event	<ul style="list-style-type: none"> ● Power ON/OFF ● H code ● D code ● Unit ON/OFF ● Date/time ● G-SET ON/OFF
7	USDA+CTS	<ul style="list-style-type: none"> ● Pulp sensor temperature (USDA #1 to #3) and cargo sensor temperature ● Date/time

Logged data can be retrieved with the aid of personal computer software. Refer to the Operation Manual for Personal Computer Software for detail.

3.6.2 SOFTWARE CONFIGURATION

	MAIN MENU	SUB MENU	Explanation of functions	Remarks	
FIELD JOB	LOGGER DATA DOWNLOAD	TRIP DATA	Data recorded in the logger is read from the controller onto the personal computer (disk or hard disk). (This operation is called the download).	No information appears on the screen at this time.	
		USDA DATA			
		4-PULP SENSORS DATA			
		PTI DATA			
	CONTAINER I.D. /HEADER	ALL DATA AFTER TRIP-START			
		SET CONTAINER I.D. /HEADER -From DISK	The logger header (set point temperature, cargo name, destination and other information) is changed. ● Data previously saved on disk is transmitted to the controller.	Disk →Controller	
		CHANGE CONTAINER I.D. -From Keyboard	The container No. (container ID) set in the controller is changed.	Input from keyboard	
		CHANGE CONTAINER HEADER -From Keyboard	The logger header is changed.	Input from keyboard	
	MAINTENANCE & REPAIR	CHANGE CALENDAR	The internal clock on the controller is changed. ● The controller clock is based on GMT (Greenwich Mean Time)	Conversion from personal computer built-in clock	
		DISPLAY CURRENT OPERATING DATA	Controller sensor values, operation of internal relay and opening rates of SMV and EV are displayed on the screen.	Record on disk is enabled.	
		DISPLAY CURRENT ALARM	Detected alarms are displayed.		
		DISPLAY ALARM LOG	Information of alarm recorded in the logger is displayed.	Record on disk is enabled.	
		DISPLAY TEMPERATURE CHART	Fluctuation of control temperature which has been recorded in the logger is displayed in a graphic chart.		
	USDA (3-PULP SENSORS) COLD -TREATMENT	REPLACE BATTERY	The back-up battery replacement day is set and displayed.	Setting can be also made on the control panel.	
		CALIBRATION USDA SENSORS	The pulp sensor (USDA sensor) to be used for low temperature transportation is calibrated.	The ice bath is used.	
	4-PULP SENSORS COLD -TREATMENT	DISPLAY TEMPERATURE CHART	Fluctuation of the pulp sensor (USDA sensor) temperature which has been recorded in the logger is displayed in a graphic chart. Summary report of trip data is indicated.		
CALIBRATION 4-PULP SENSORS		The pulp sensor (USDA sensor) to be used for low temperature transportation is calibrated.	The ice bath is used.		
	DISPLAY TEMPERATURE CHART	Fluctuation of the pulp sensor (USDA sensor) temperature which has been recorded in the logger is displayed in a graphic chart. Summary report of trip data is indicated.			

	MAIN MENU	SUB MENU	Explanation of functions	Remarks
OFFICE JOB	MAKE REPORT	TRIP REPORT	Reports are made based on record data read from the logger.	
		USDA REPORT		
		4-PULP SENSOR REPORT		
		PTI REPORT		
		ALARM REPORT		
		MONITOR REPORT		
		EVENT REPORT		
	MAKE CONTAINER I.D. /HEADER	SET CONTAINER I.D. /HEADER into DISK	Disk data to change LOGGER HEADER of controller is created.	
CONFIG SET	<ul style="list-style-type: none"> • CHART MARK • CRT MODEL • SET TIME ZONE • G.M.T-LOCAL TIME 	<ul style="list-style-type: none"> • SELECT JOB • TRIP REPORT 	Environment using personal computer software is set.	

3.7 Inspection procedure for the electronic controller

DECOS III d enables the internal data of the controller CPU (RAM data) to be displayed on the monitor of a personal computer by connecting the two with a communication cable. This makes it possible to preform an easy inspection of the controller and diagnose any defect.

(1) Inspection of sensors

The inspection is carried out by comparing the sensor readings on the controller display with the display on the personal computer. In case the sensor reading is abnormal, the sensor should be replaced with a new one, but **be sure to check the sensor for damage as well as the internal harness and its connectors before replacing.** (Refer to Appendix for the sensor characteristics.)
Page 7-4 and 7-5.

(2) Inspection of the internal relays of the electronic controller

The inspection is carried out by checking the display on the personal computer and the internal relay output (24VAC) on the terminals of terminal board, utilizing the electric tester or test lamp. In case the internal relay malfunctions, the power I/O board should be replaced with a new one, but **be sure to check the internal harness and its connectors for damage before replacing.**

(3) Inspection of the Suction modulation valve

Suction modulation valve is driven by the PCB adapter. If the Suction modulation valve does not function (i.e. if there is no clicking sound, ever though the control display shows the valve opening and closing), then the PCB adapter should be replaced, but be sure to check the internal harness and its connectors for damage before replacing.

(4) Inspection of the electronic expansion valve

If the electronic expansion valve does not operate (no clicking sound) when the valve opening is changed on the controller indication, the electronic expansion valve should be replaced. However, **check on damage of internal harness and poor contact of connector before the replacement.**

(5) Inspection of the cpu board

If the green light on the cpu board is flashing, then the cpu board is working normally.

●Basic internal wiring diagram of electronic controller

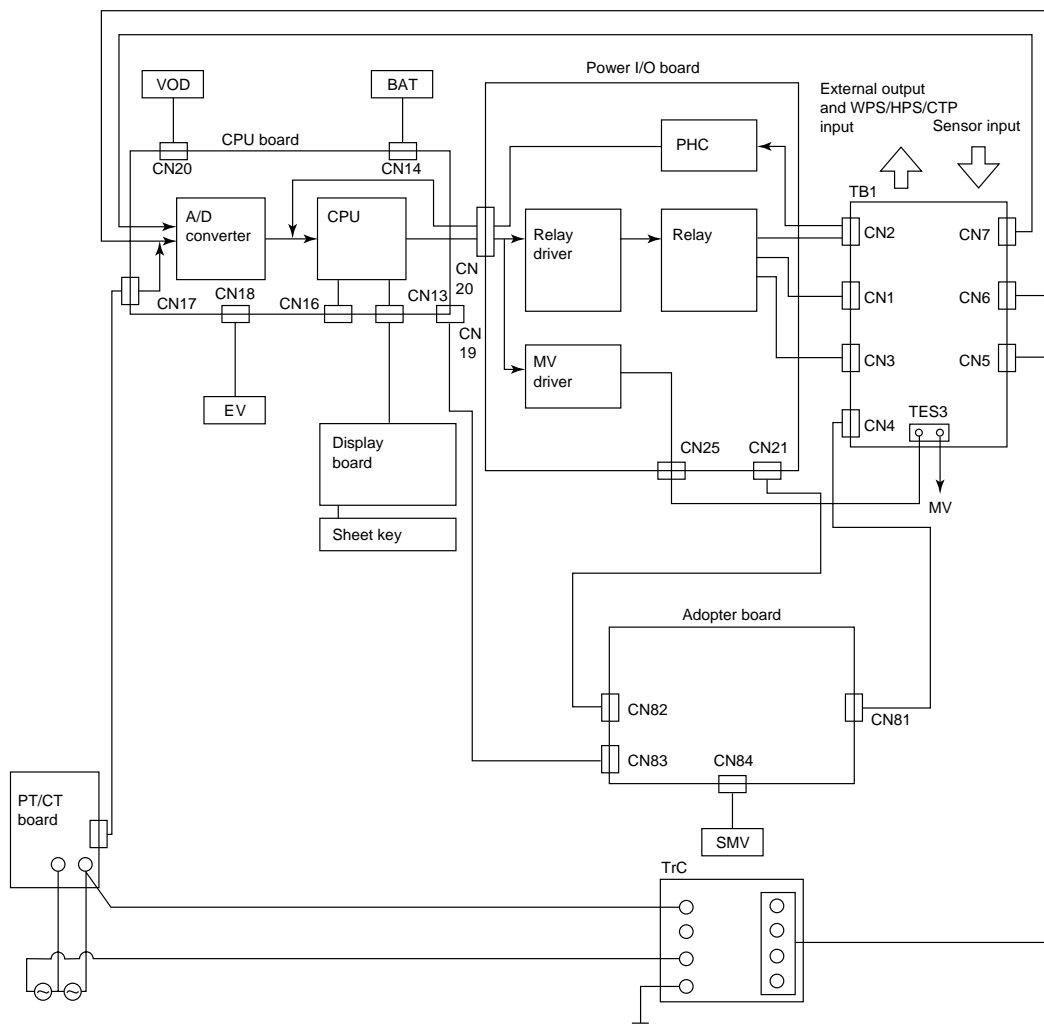

3.8 Controller replacement and initial setting

3.8.1 Controller replacement

<Replacement procedure for the controller>

(1) Remove speed bolts (2 pcs) on the controller body, then remove the connector.

Be sure to keep voltage indicator, the battery and the battery fixing plate for reinstallation.

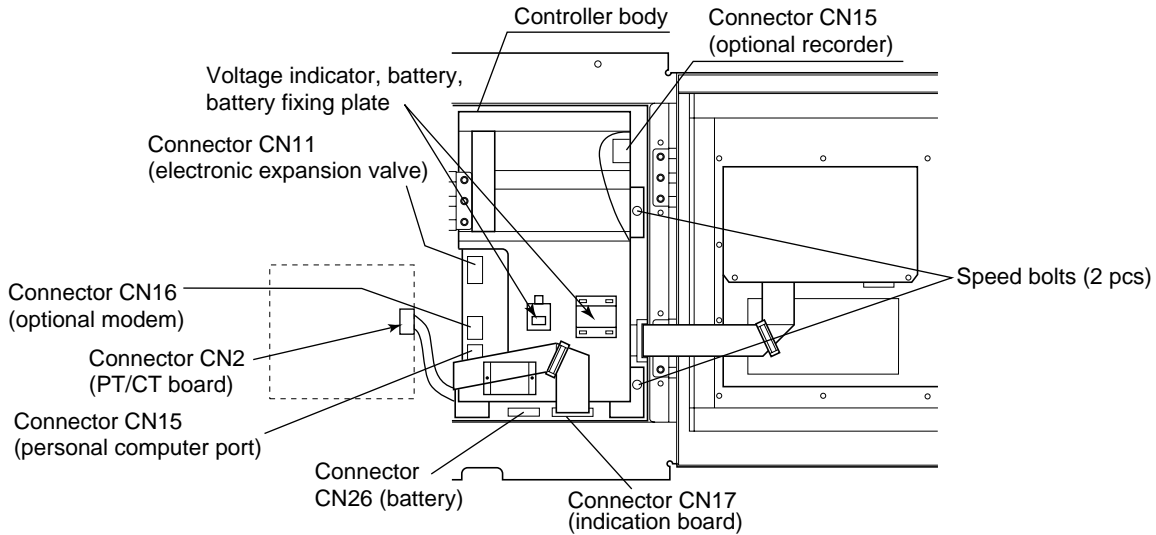

(2) Open the controller body, then disconnect the connectors ② through ⑧ and ⑪ on the terminal board mounting plate ⑩.

(3) Disengage clamps ⑨ fixing the harness.

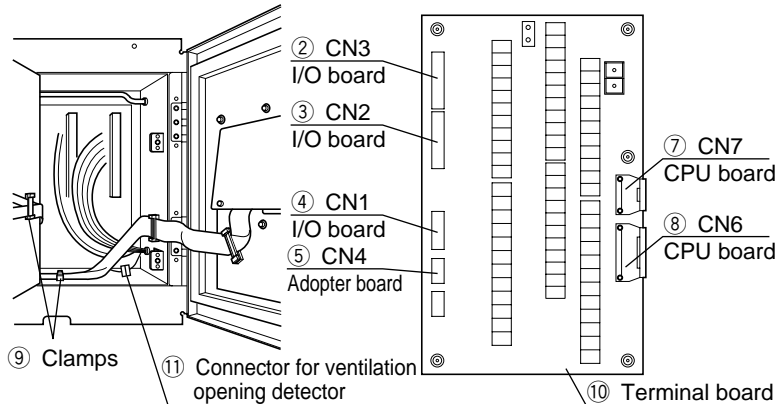

(4) Remove screws (2 pcs) fixing the controller, and replace the controller with a new one.

(5) In the reverse procedure, set the connector, the terminal speed bolts and the mounting screws into the original setup.

Install the battery and the voltage indicator removed from the previous controller before replacement by using the battery fixing plate.

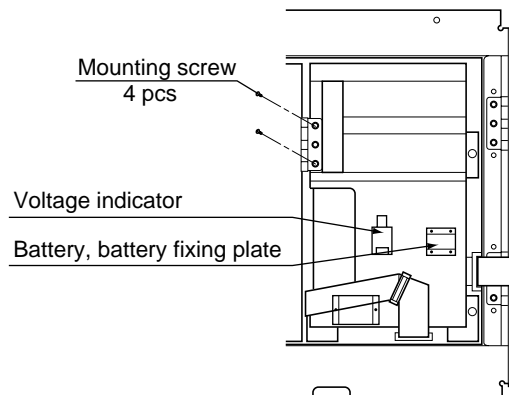

CAUTION Make sure that the connector is firmly connected.

3.8.2 INITIAL SETTING & OPERATION PROCEDURE

Key operation

- Underlined figures show "Factory set" in this model. Other choices are described in ().
If there is not specify special instruction, set all figures to "Factory set".
- Select "Factory set" with or key and fix it with key.
- If the setting is not completed, and the circuit breaker is switched OFF and ON, the display will return to the incomplete setting.

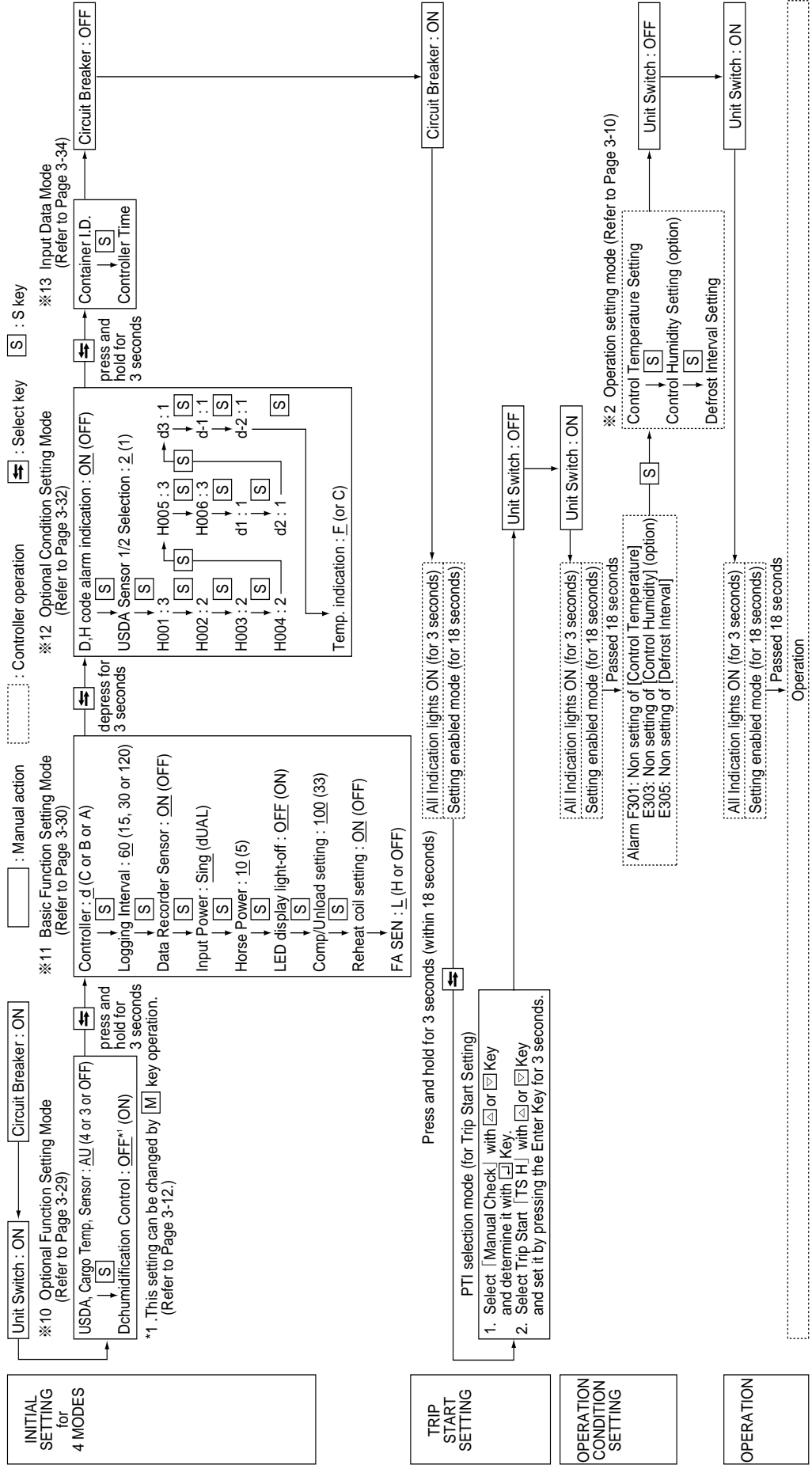

3.9. PTI (Pre-Trip Inspection) AND PERIODIC INSPECTION

The controller (DECOS III d) has the automatic PTI function, which consists of three process of SHORT PTI (referred to as S.PTI hereafter), FULL PTI (referred to as F.PTI hereafter) and MANUAL CHECK (referred to as M.CHECK hereafter)

Mode	Operation description
S.PTI	The components are inspected for abnormalities. Even if any abnormal components are found, all processes are executed.
F.PTI	S.PTI + unit cooling capacity inspection are executed. The cooling capacity check is executed only if any abnormal components are not found with S.PTI. If any abnormality is found during the cooling capacity inspection, F.PTI is terminated.
M.CHECK	The functional parts and the operation data can be inspected.

The abnormalities which occur during automatic PTI will be displayed on the controller when the automatic PTI is terminated.

- Refer to section 3.4 for the alarm code checking procedure.
- Refer to section 6.2 for the alarm code contents.

When automatic PTI is terminated, the result of the PTI can be output as a report with using a personal computer. (Refer to the Operation Manual for Personal Computer Software.)

3.9.1 Inspection item

The periodic inspection and adjustment of components (if required) is recommended to ensure continued successful operation.

The following table shows an example of the inspection plan.

No.	Inspection item	Inspection content	PTI	2 nd year	4 th year	8 th year	
General structure	1	Inspection for physical damage	○	○	○	○	
	2	Loose mounting bolts	1) Casing frame	○			
			2) Compressor	○			
			3) Condenser fan motor	○			
			4) Evaporator fan motor	○			
			5) Control box	○			
			6) Temperature recorder box	○			
			7) Access panel	○			
			8) Others		○	○	○
	3	Conditions of panel, hinge and lock		○	○	○	
	4	Drain pan and drain hose cleaning	○				
	5	Control box inspection	1) Cover packing inspection and replacement	○	○	○	○
			2) Loose cable gland		○	○	○
			3) Internal cleaning		○	○	○
	6	Temperature recorder box inspection	1) Cover packing inspection and replacement	○	○	○	○
			2) Internal cleaning		○	○	○
	7	Sealing condition of holes through casing frame	1) Air leakage and clearance	○	○	○	○
	8	Packing inspection and replacement	1) Ventilator cover packing		○	○	○
			2) Unit sealing packing				○
9	Painted area recondition	1) Compressor		○	○	○	
		2) Water-cooled condenser/liquid receiver		○	○	○	
		3) Solenoid valve (coil cap)		○	○	○	
		4) Casing frame			○	○	
10	Repainting	1) Compressor				○	
		2) Water-cooled condenser/liquid receiver				○	
		3) Condenser fan motor				○	
		4) Condenser fan				○	
Refrigerant system	1	Gas leakage	○	○	○	○	
	2	Refrigerant	1) Inspection of moisture in the refrigerant, and refrigerant charged amount	○			
			2) Replacement of refrigerant			○	○
	3	Inspection of high pressure switch operational pressure	○				
	4	Operation and leakage of solenoid valve	1) Liquid solenoid valve	○			
			2) Economizer solenoid valve	○			
			3) Injection solenoid valve	○			
			4) Hot gas solenoid valve	○			
			5) Defrosting solenoid valve	○			
			6) Discharge gas by-pass solenoid valve	○			
5	Operation and leakage of suction modulating valve	○					
6	Operation and leakage of electronic expansion valve	○					
7	Compressor	Water entering to compressor terminal		○	○	○	

	No.	Inspection item	Inspection content	PTI	2 nd year	4 th year	8 th year
Refrigeration system	8	Dryer replacement			○	○	○
	9	Function inspection and replacement of liquid moisture indicator		○			○
	10	Conditions of fasteners on the refrigerant pipes and gauge pipes			○	○	○
	11	Condition of thermal insulation of refrigerant pipe			○	○	○
	12	Evaporator coil cleaning (BY water)			○	○	○
	13	Condenser coil cleaning	1) Water-cleaning	○	○	○	○
			2) Steam-cleaning (after pumping down the refrigerant)			○	○
14	Water-cooled condenser inspection	1) Water-leakage inspection		○	○	○	
		2) Operation of water pressure switch		○	○	○	
Electrical system	1	Damage of power cable and plug		○	○	○	○
	2	Inspection of conditions of internal wiring			○	○	○
	3	Terminal looseness inspection and retightening if necessary	1) Magnetic switch	○	○	○	○
			2) Electronic controller terminal block	○	○	○	○
			3) Terminal block	○	○	○	○
	4	Condition of monitoring receptacle cap		○	○	○	○
	5	Conditions of personal computer receptacle cap		○	○	○	○
	6	Fuse conditions	1) Burned out or not	○	○	○	○
	7	Magnetic switch contact point inspection and replacement	1) Contact point inspection	○	○	○	
			2) Replace the contact on compressor contactor			○	○
			3) Replace the contact on compressor fan motor				○
			4) Replace the contact on evaporator fan motor				○
	8	Electric insulation check	1) Power cable and plug	○	○	○	○
2) Compressor			○	○	○	○	
3) Condenser fan motor			○	○	○	○	
4) Evaporator fan motor			○	○	○	○	
9	Starting procedure inspection		○				
10	Thermosensor	1) Installation conditions of sensor	○	○	○	○	
		2) Inspection of sensor and sensor lead for damage		○	○	○	
		3) Indication error inspection and replacement		○	○	○	
11	Humidity sensor	1) Indication error inspection and replacement	○				
		2) Replacement		○	○	○	
12	PT/CT (voltage and current) indication error inspection			○	○	○	
13	Pressure sensor indication error inspection and replacement			○	○	○	

	No.	Inspection item	Inspection content	PTI	2 nd year	4 th year	8 th year
Electrical system	14	Temperature recorder inspection	1) Calibration	○			
			2) Sensor error inspection and replacement		○	○	○
			3) Chart drive inspection	○			
			4) Recording operation inspection	○			
			5) Loose terminal		○	○	○
			6) Chart drive dry battery inspection, and replacement	○			
			7) Check and replacement of pen lifting battery				○
	15	Electronic controller	1) Check and replacement of wake-up battery	○			
			2) LCD panel replacement			○	○
	16	Evaporator fan motor	1) Speed switchover	○			
			2) Revolution direction	○			
			3) Motor replacement				○
	17	Condenser fan motor	1) Rotating direction	○			
			2) Motor replacement				○
18	Evaporator fan	1) Deformation and damage inspection	○		○	○	
19	Condenser fan	1) Deformation and damage inspection	○	○	○	○	
Others	1	Check for abnormal noise and vibration during operation		○			
	2	Temperature control function	1) 0°C operation	○			
			2) -18°C operation	○			
	3	Defrosting function		○			
	4	Unit water-cleaning		○			
5	Ventilation opening detector function	1) Calibration	○				

※ The service life of the wake-up battery is approx. one year (alkali battery). For USDA transportation, replace the battery with a new alkali battery when PTI is performed.

3.9.2 Automatic PTI (Pre-Trip Inspection)

- The automatic PTI function is provided so as to ensure correct inspection and to shorten inspection time.

(1) Appearance inspection of unit

- ① Physical damage
- ② Casing insulation through hole area
- ③ Drain hose (dust and clogging)
- ④ Power cable and plug damage
- ⑤ Condition of refrigerant piping fasteners.
- ⑥ Condition of each sensor installation
- ⑦ Loose mounting sections
 - Bolts and nuts ----- Casing frame, compressor, fan motor control box and temperature recorder box
 - Cable glands ----- Control box
- ⑧ Conditions of control box cover packing (water-proof) and temperature recorder box cover packing (water-proof)
- ⑨ Magnetic contactor contact point for burning out.

(2) Inspection before unit operation

- ① Gas leakage inspection

② Power voltage inspection (Automatic PTI range)

(3) Starting inspection and operation inspection of safety device and control equipment

- ① Starting
 - Inspection whether the starting procedure is proper or not
 - Inspection for abnormal noise and abnormal vibration
 - Moisture in the refrigerant ----- This is reinspected at the end of PTI.
 - Rotating direction of fan motor.
- ② Safety device
 - HPS ----- Measurement of the actuating pressure by stopping the condenser fan motor.
- ③ Control equipment

Solenoid valve	-----	Inspection of operation (open and close) and leakage
EFM	-----	Speed switchover and rotating direction
EV, SMV	-----	Inspection of operation (open and close) and leakage

(4) Operation in each mode

- | | | | |
|-------------------|-------|---|--|
| ① Pull-down → | 0°C | | Pull-down time, voltage and current |
| ② Chilled control | 0°C | Electronic temperature recorder calibration | Return, supply air temperature differential, voltage and current |
| ③ Defrosting | | | Defrosting time |
| ④ Pull-down → | -18°C | | Pull-down time, evaporator fan motor speed switchover |
| ⑤ Frozen control | -18°C | Electronic temperature recorder calibration | (Temperature differential and rotating direction)
ON/OFF, voltage and current |

Remained frost inspection

(5) PTI report preparation

3.9.2.1 PTI SELECTION MODE

The test mode of FULL (F.PTI), SHORT PTI (S.PTI), and MANUAL CHECK (M.CHECK) can be selected.

<Mode selection procedure>

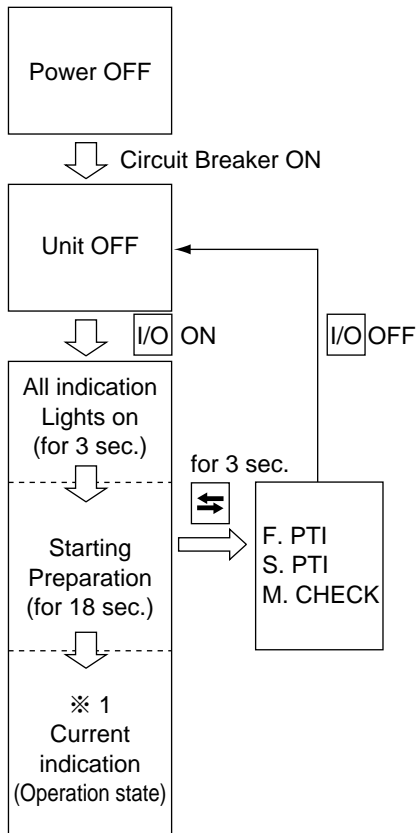

<Operation procedure>

Whenever the or key is pressed, the indication changes.

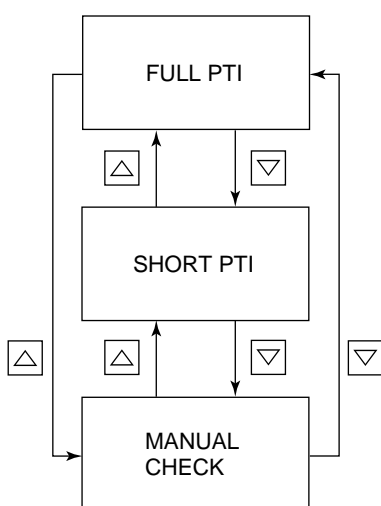

To start FULL PTI, press the key while "F.PTI" is display on the LCD.

To start SHORT PTI, press the key while "S.PTI" is display on the LCD.

● When the key is pressed while "M-CHECK" is displayed on the LCD, the manual check selection mode is set.

The detail of the manual check selection mode is described in the following pages.

● Automatic PTI enable conditions

	Water cooled operation	Air cooled operation	Ambient temperature condition
S. PTI	×	○	-10°C < Ambient temperature ≤ 43°C When the ambient temperature is above 43°C or below -10°C, the result may be abnormal.
F. PTI	×	○	-10°C ≤ Ambient temperature ≤ 43°C When the ambient temperature is above 43°C or below -10°C, the following alarm will be indicated. J501: Out of ambient temperature specified condition.
M. CHECK	○	○	

3.9.2.2 Short PTI (S.PTI)

● Step display and content

Step	Content
P00	Basic data record (container No., date, time, compressor integrated run-hour, ambient temperature)
P02	Alarm check on all sensors
P04	Power conditions (voltage and frequency) check
P05	Compressor start running check
P06	Actuating pressure check at OFF and ON of High pressure switch (HPS)
P08	Pump-down check
P10	Solenoid valve leakage check •Liquid solenoid valve (LSV) •Injection solenoid valve (ISV) •Hot gas solenoid valve (HSV) •Defrost solenoid valve (DSV) •Discharge gas by-pass (BSV) •Economizer solenoid valve (ESV)
P12	Supply and return air sensor (SS and RS) accuracy check
P14	Pressure sensor (HPT and LPT) accuracy check
P16	Evaporator fan high and low-speed operation check
P18	Start up
P20	Economizer solenoid valve (ESV) opening or closing check※1 ※2
P22	Discharge gas by-pass solenoid valve (BSV) opening or closing check※2
P24	Defrost solenoid valve (DSV) opening or closing check
P26	Standard pull-down operation
P28	Suction modulating valve (SMV) operation check
P29	Electronic expansion valve (EV) operation check
P30	Injection solenoid valve (ISV) opening or closing check※2
P32	Hot-gas 3-way solenoid valve (HSV) and reheat coil solenoid valve (RSV) opening or closing check

※1 If the ambient temp is -10°C or lower, the function check of the solenoid valve cannot be performed correctly, short circuit the terminals 121 and 102 on the terminal board, and check the operation of the solenoid valve.

※2 If the difference between ambient temperature and return air temperature is 15°C or higher, these steps will be skipped.

● S.PTI Flow chart operation

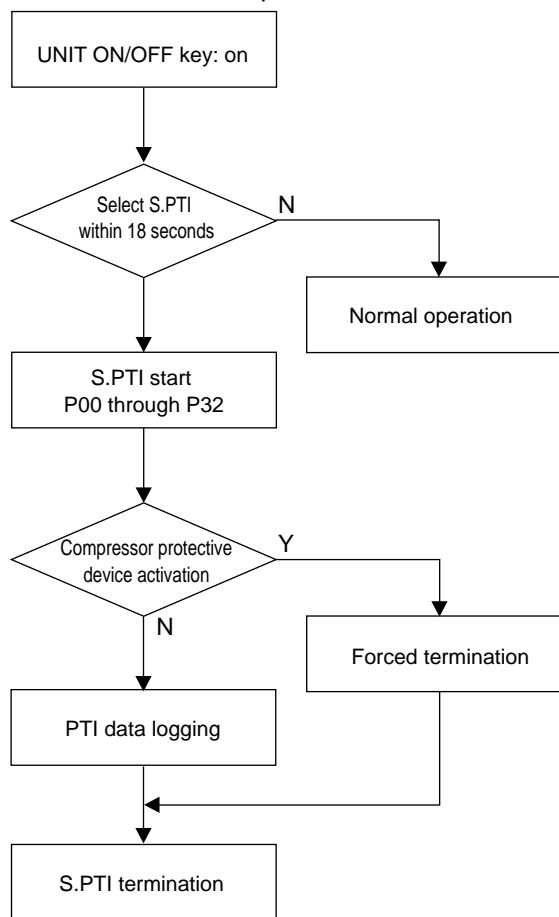

3.9.2.3 Full PTI (F.PTI)

F.PTI consists of S.PTI and operation tests.

●Step display and contents

(step P00 to P32 are as same as S.PTI)

Step	Content
P50	Check on pull-down to 0°C
P60	Check on controllability of chilled mode operation.
P70	Check on defrosting
P80	Check on pull-down from 0°C through -18°C
P90	Check on controllability of frozen mode operation

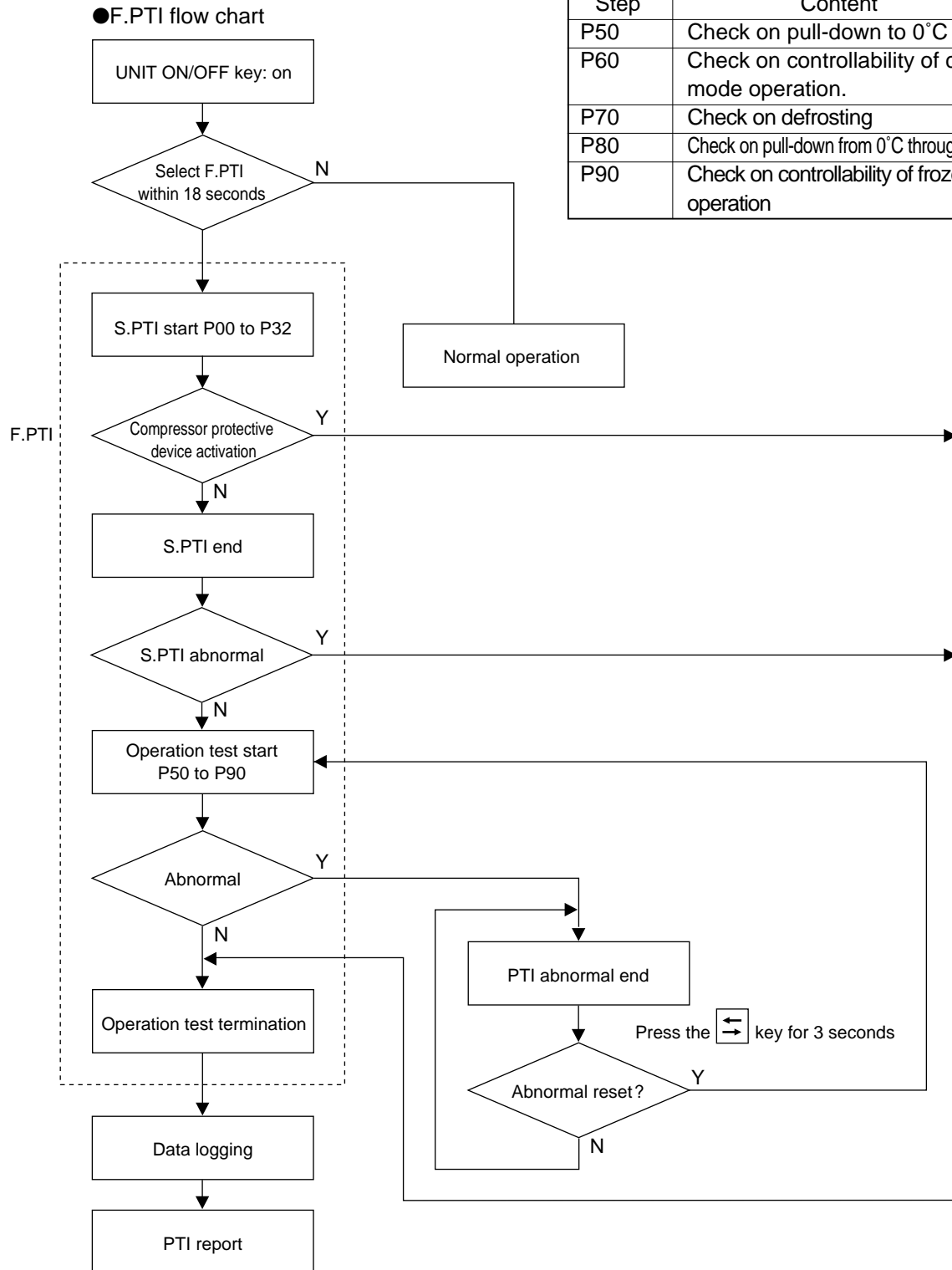

IMPORTANT

When Full PTI is executed, the following settings are reset to default.

- ① Setting temperature : Previous setting temperature
- ② Defrost interval : 6 Hours
- ③ Log interval : 60 minutes
- ④ Dehumidification : off
- ⑤ G set : off

3.9.2.4 Alarm list during PTI (Pre-Trip Inspection)

The alarm during automatic PTI are concerned with PTI inspection items in addition to those during normal operation.

The alarms at automatic PTI are indicated in J ※※※., being separated from those during normal operation.

There are some alarms which are not displayed on the control panel, however, they can be checked referring to the PTI report.

Check NO. (LED display)	Check content	Alarm Indication (LED display)	Alarm content	S.PTI	F.PTI	Remarks
P00	Basic data	No indication	Check basic-data	↑	↑	
P02	All sensor	Same as normal operation	Check basic-data			
P04	Power supply	No indication	Check basic-data			
P05	Starting	J051	Compressor malfunction			
P06	HPS	J061	Abnormal OFF value			
	”	J062	Not recovered (Not reset)			
	”	J064	High pressure does not rise.			
	”	J065	High pressure does not drop.			
P08	Pump-down	J081	Long pump-down			
P10	Liquid solenoid valve	J101	Valve leakage			
P12	RS, SS accuracy	J121	Sensor deterioration			
P14	HPT, LPT accuracy	J141	Sensor deterioration			
P16	Evaporator fan motor	J161	Evaporator fan motor malfunction			
P20	Economizer solenoid valve	J201	Economizer solenoid valve malfunction			
P22	Discharge gas by-pass solenoid valve	J221	Discharge gas by-pass solenoid valve malfunction			
P24	Defrost solenoid valve	J241	Defrost solenoid valve malfunction			
P26	Operation	No indication	Judged with P28			
P28	Suction modulating valve	J281	Suction modulating valve does not activate			
P29	Electronic expansion valve	J291	Long pump-down			
P30	Injection solenoid valve	J301	Injection solenoid valve malfunction			
P32	Hot-gas solenoid valve	J321	Hot-gas solenoid valve malfunction			
	Reheat coil solenoid valve	J322	Reheat coil solenoid valve malfunction	↓		
P50	Pull-down cooling capacity	J501	Out of ambient temperature conditions	↓	↓	
P50	0°C control	J502	Long pull-down time			
P60	0°C control	No indication				
P70	Defrosting	J701	Out of starting conditions			
		J702	Long defrosting time			
P80	Pull-down cooling capacity	J801	Long pull-down time			
P90	-18°C control	No indication				

Refer to chapter 6.3 for more information.

3.9.2.5 Manual check (M.CHECK)

Since the components are operated individually differing from S.PTI and F.PTI, the steps can be respectively selected and executed. However, any error occurring during execution of M.CHECK will not be included.

Turn the UNIT ON/OFF key off to terminate the M.CHECK.

● Step indication and contents

Step (indicated on the LCD)	Indication content (indicated on the LED)
FA CAL	Fresh air 0 point adjustment (calibration)
CC X10H	Compressor integrated run-hour
EFH A	Running current value of evaporator fan motor high-speed running
EFL A	Running current value of evaporator fan motor low-speed running
CF A	Running current value of condenser fan motor running
TS H	Elapsed time after trip start
EF1 X 10H	Evaporator fan motor 1 run- hour
EF2 X 10H	Evaporator fan motor 2 run- hour
CF X 10H	Condenser fan run- hour
SOFTVER	Controller software version

● M.CHECK flow chart

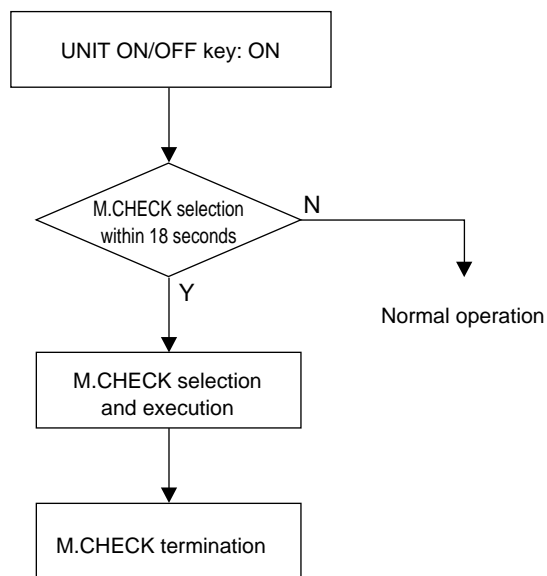

MANUAL CHECK SELECTION MODE

The LED displays the values of following items:

Compressor operating time, Evaporator fan motor high-speed running current, Evaporator fan motor low-speed running current, Condenser fan motor running current, Battery life, Horse power, Elapsed time after trip start, Evaporator fan motor running time, Condenser fan motor running time, and Controller software version.

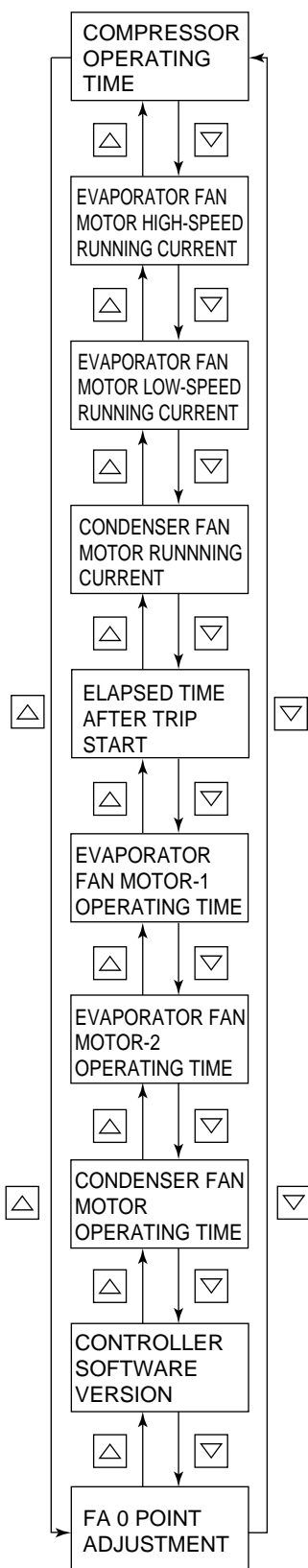

To display the compressor operating time:

Press the key when the LCD shows "CC X10H".

The operating time is [the value shown on the LED] X10 hours.

Pushing the key for 3 seconds sets compressor operating time to 0 (hour).

To display the current value of the evaporator fan motor high-speed:

Press the key when the LCD shows "EFH A", then the LED displays the current value. (Unit: Ampere)

To display the current value of the evaporator fan motor low-speed:

Press the key when the LCD shows "EFL A", then the LED displays the current value. (Unit: Ampere)

To display the current value of the condenser fan motor running current:

Press the key when the LCD shows "CF A", then the LED displays the current value. (Unit: Ampere)

To display the elapsed time after trip start:

Press the key when the LCD shows "TS H", then the LED displays the elapsed time. (Unit: Hours).

When the key is pressed and hold for 3 seconds while the elapsed time is displayed the TRIP START is set, and the elapsed time display is reset to "0" (hour).

To display the evaporator fan motor-1 operating time:

Press the key when the LCD shows "EF1 X10H".

The operating time is [the value displayed on the LED] X10 hours.

When the key is pressed and hold for 3 seconds while the evaporator fan motor-1 operating time is displayed, the evaporator fan motor-1 operating time is reset to "0" (hour).

("EF1" stands for the right hand side fan motor looking from the inside of the container.)

To display the evaporator fan motor-2 operating time:

Press the key when the LCD shows "EF2 X10H".

The operating time is [the value displayed on the LED] X10 hours.

If the key is pressed and hold for 3 seconds while the evaporator fan motor-2 operating time is displayed, the evaporator fan motor-2 operating time is reset to "0" (hour).

"EF2" stands for the left hand side fan motor looking from the inside of the container.

To display the condenser fan motor operating time:

Press the key when the LCD shows "CF X10H".

The operating time is [the value displayed on the LED] X10 hours.

If the key is pressed and hold for 3 seconds while the condenser fan motor operating time is displayed, the condenser fan motor operating time is reset to "0" (hour).

To display the controller software version:

Press the key when the LCD shows "SOFTVER".

The value on the LED is the software version.

FA ZERO-POINT ADJUSTMENT

Used to make automatic zero-point adjustment of ventilation amount.

Pressing the key while the "FA CAL" is displayed on the LCD will display the current value of ventilation port sliding amount. Pressing and holding the key for a period of 3 seconds while the sliding amount is displayed on the LCD, the sliding amount will be reset to "0".

3.10. CHARTLESS FUNCTION

The controller provides the temperature recorder function. This function, displays the control temperature logging data during operation on the LCD panel in a simple graphic chart so that the data can be confirmed easily. (Chart indication function)

The chart, temperature and alarm record scroll indication are based on the control sensor data (SS/RS). When the data recorder sensors (DSS/DRS) are optionally provided, the chart indication is based on the data recorder sensor data preferentially.

3.10.1 Chart indication mode

The temperature record data is indicated in a graphic chart on the LCD panel in the chart indication mode.

- The displayed log period is selected from 12 hours (1 HOURS on the time base) or 6 days (2 DAYS on the time base).
- The displayed intervals are 2 hours for 12 hours log (1 HOURS) and one day for 6 days log (2 DAYS).
- The indication of the data during the defrosting is flickered, and the indication of the other chart data is lit on.

● LCD panel

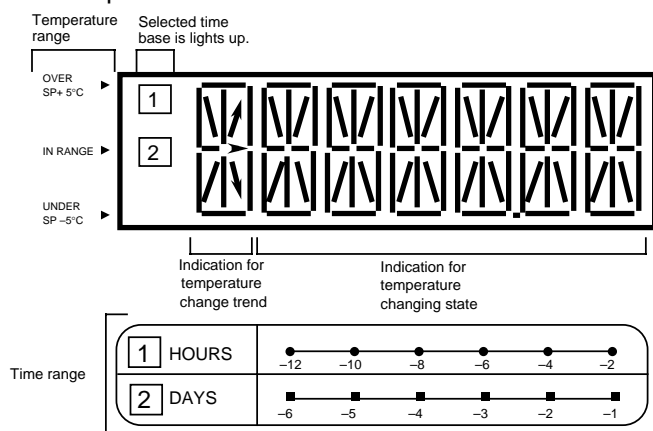

● Example of chart indication

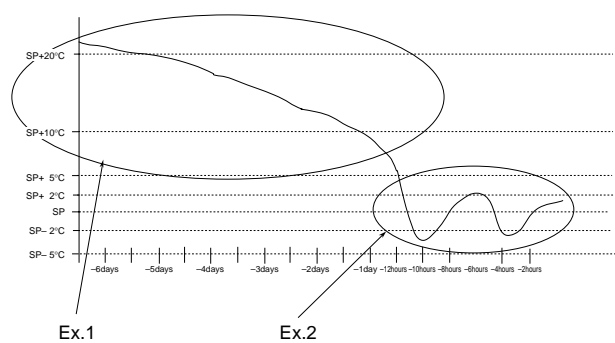

Ex.1

The arrow indicates the temperature change trend when all segments are in the same temperature range.

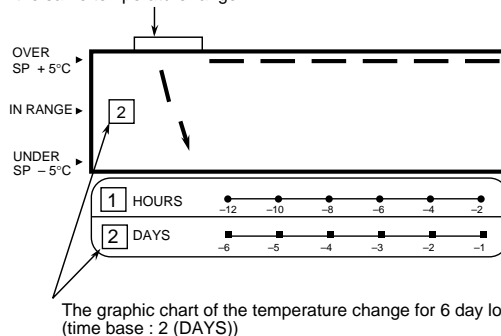

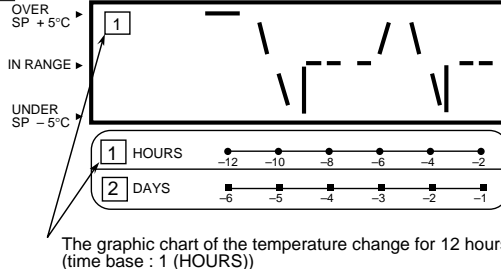

Ex.2

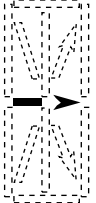

● Displaying temperature change trend:

- The temperature change trend is shown in the leftmost LCD.
- However, this display is shown only when all segments are in the same temperature range.

Trend indication	Condition
<p>Temperature rise trend</p> 	$\left(\begin{array}{l} \text{The latest} \\ \text{data on the} \\ \text{chart} \end{array} - \begin{array}{l} \text{the oldest} \\ \text{data on the} \\ \text{chart} \end{array} \right) > \text{※ set point of H001} \\ \text{(ALARM indication} \\ \text{setting)}$
<p>Temperature stable tendency</p> 	$\left(\begin{array}{l} \text{The latest} \\ \text{data on the} \\ \text{chart} \end{array} - \begin{array}{l} \text{the oldest} \\ \text{data on the} \\ \text{chart} \end{array} \right) < \text{set point of H001}$ <p>or</p> $\left(\begin{array}{l} \text{the oldest} \\ \text{data on the} \\ \text{chart} \end{array} - \begin{array}{l} \text{The latest} \\ \text{data on the} \\ \text{chart} \end{array} \right) < \text{set point of H001}$
<p>Temperature fall tendency</p> 	$\left(\begin{array}{l} \text{the oldest} \\ \text{data on the} \\ \text{chart} \end{array} - \begin{array}{l} \text{The latest} \\ \text{data on the} \\ \text{chart} \end{array} \right) > \text{set point of H001}$

※ According to setting point of H001, trend indication changes.

Refer to page 3-32 optional condition setting mode for the H001 setting procedure.

< Operation procedure >

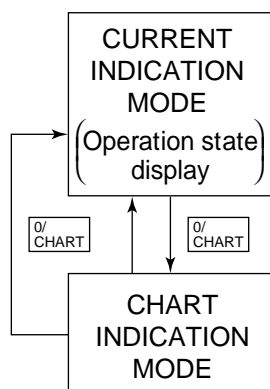

To shift to the chart indication mode, press the $\boxed{\text{CHART}}$ key while the unit is in the current indication mode.

In the chart indication mode, the LCD displays a simple graphic chart. The ordinate at the left side of LCD screen for temperature base and the abscissa at the bottom of LCD for time base are indicated.

The No. indicated at the time base is the same as the No. on the left most of the LCD, which indicates the simple graphic chart is of 12 hours log or 6 days log indication.

Select the base to be uses using the $\boxed{\Delta}$ or $\boxed{\nabla}$ key.

When the $\boxed{\text{CHART}}$ key is pressed, the unit goes back to the current indication mode.

3.10.2 P code (Pull down time indication)

The control temperature and pull-down time are indicated alternately during pull-down operation. When the pull-down is completed, the P code will be deleted.

P001: Lasts the pull-down for 1 hour. /P002: 2 houes passed since pull-down started.

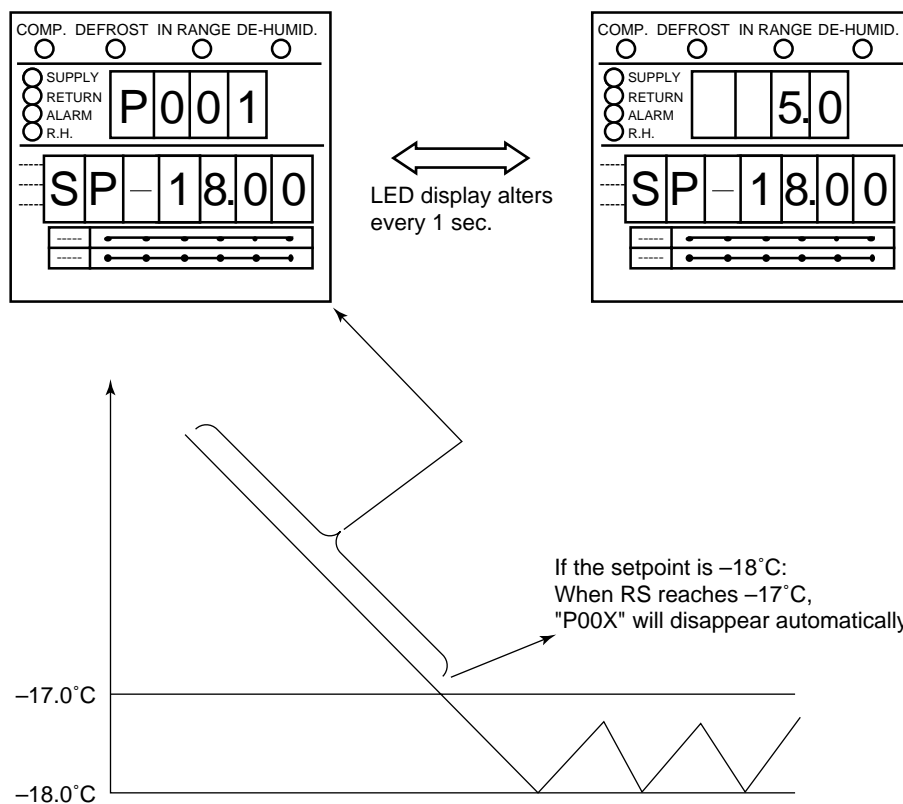

Figure1

3.10.3 Chartless code display function

The chartless code represents the coded inside air temperature.

Select "ON" of the chartless code setting to indicate the code on the LED.

For the chartless code setting, refer to the "optional conditions setting" on the page 3-29.

- P code: Indicates the pull-down time.
- H code: Indicates the abnormal temperature records.
- d code: Indicates the operation history.

3.10.3.1 List of chartless code

C: chilled mode, F: Frozen mode, PF: Partial frozen mode

	Code	Description	Operation mode	Figure
Abnormal temperature record	H001	The alarm is displayed when the control temperature does not decrease by <u>3°C</u> or more for every 4 hours during pull-down operation.	C, F, PF	2
	H002	The alarm is displayed when the total out-of- in-range reaches <u>2 hours</u> . (Count is not performed during defrosting.)	C, F, PF	3
	H003	The alarm is displayed when the integrated time of state "below SP-1°C" reaches <u>2 hours</u> .	C	4
	H004	The alarm is displayed when the integrated time of state "below SP-2°C" reaches <u>2 hours</u> .	C	4
	H005	The alarm is displayed when the control air temperature is Out-of -In-Range and defrosting was performed successively <u>three times</u> while the control air temperature does not return to in-range.	C, F, PF	5
	H006	The alarm is displayed when the integrated time of difference 2 °C or more between control sensor data and record sensor data reaches to <u>one hour</u> or more.	C, F, PF	6
Operation history	d3XX	When the total time above set point +3°C reaches <u>1 hour</u> , the code "d301" will be displayed.	C, F, PF	7
	d2XX	When the total time above set point +2°C reaches <u>1 hour</u> , the code "d201" will be displayed.	C, F, PF	7
	d1XX	When the total time above set point +1°C reaches <u>1 hour</u> , the code "d101" will be displayed.	C, F, PF	7
	d-1X	When the total time below set point -1°C reaches <u>1 hour</u> , the code "d-11" will be displayed.	C, F, PF	7
	d-2X	When the total time below set point -2°C reaches <u>1 hour</u> , the code "d-21" will be displayed.	C, F, PF	7
	PXXX	XXX: When the total pull-down time reaches one hour, an indication XXX=001 appears.	C, F, PF	1

Note 1) The encircled setting can be changed.

Note 2) To delete the H code or d code, press the  key for 3 seconds during the relevant code indicated.

Note 3) H code and d code are deleted when turn off the power supply for 3 days.

3.10.3.2 H-code

H001 =The alarm is displayed when the control temperature does not decrease by 3°C or more every 4 hours during pull-down operation.

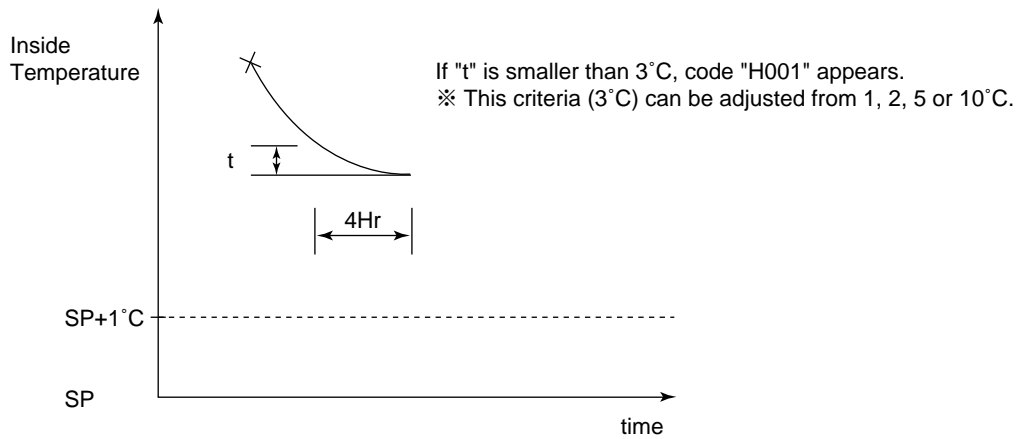

Figure2

H002 =The alarm is displayed when the total time out of "in-range" reaches 2 hours. (Counting is not performed during defrosting).

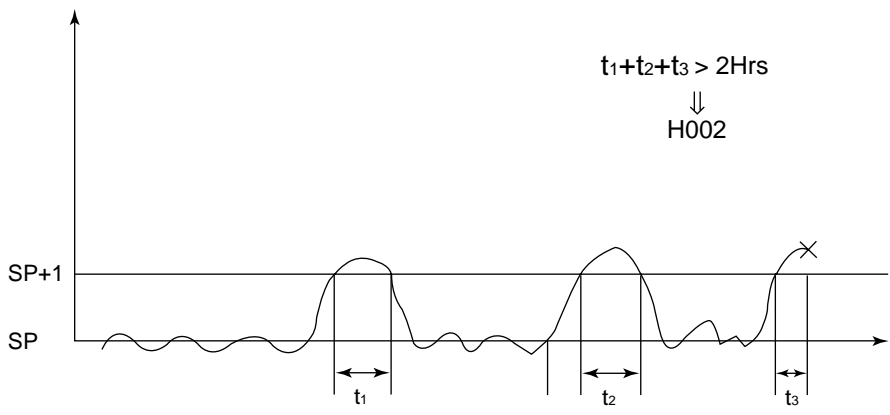

Figure3

H003 =The alarm will be displayed when the total time below setpoint -1°C reaches 2 hours.

H004 =The alarm will be displayed when the total time below setpoint -2°C reaches 2 hours.

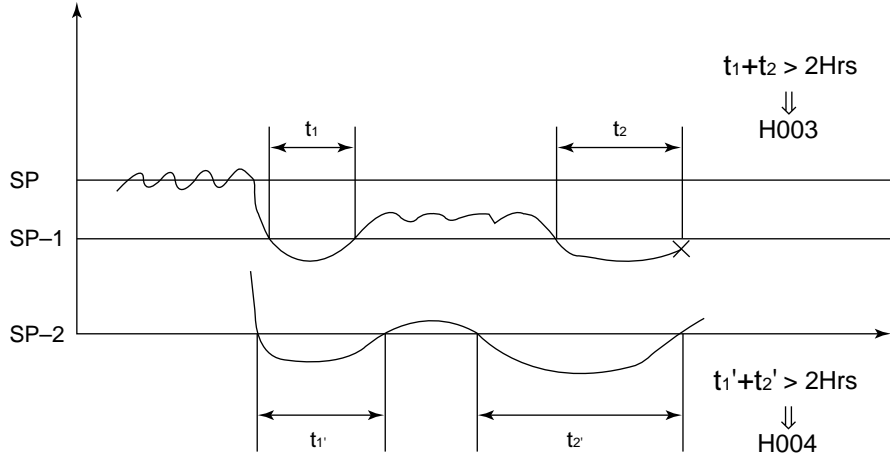

Figure4

H005 =The alarm is displayed when the control air temperature is out of "in-range" and defrosting was performed three times while the control air temperature does not return to in-range.

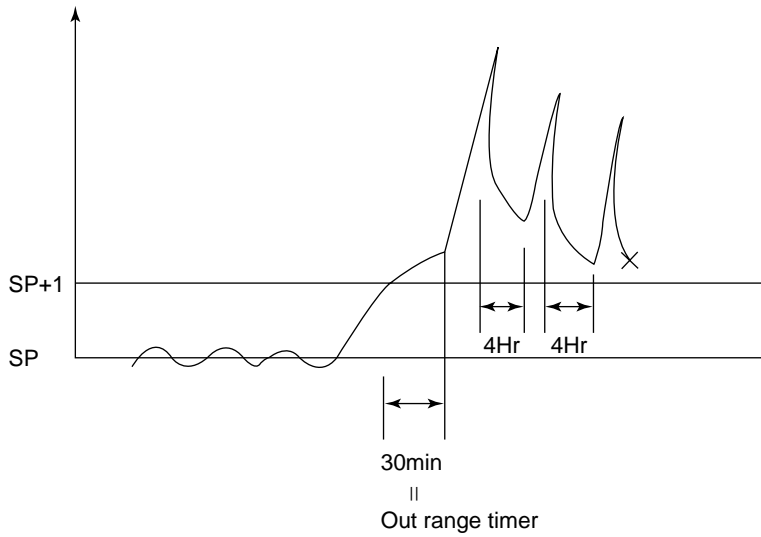
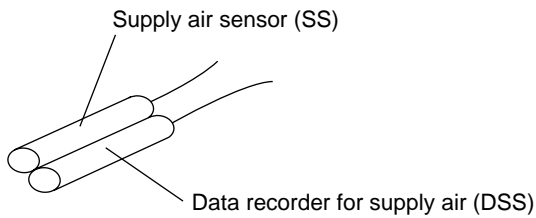

Figure5

H006 =Alarm is displayed when the temperature difference between the control sensor and record sensor is 2°C for 1 hour, or more.



$|DSS - SS| > 2^{\circ}C \rightarrow$ **H006**

Figure6

3.10.3.3 d-code:

The d-code shows the current operation state of the unit.

Example d101:

- This code "d101" will be displayed when the total time above set point $+1^{\circ}\text{C}$ reaches 1 hour.
The code "d102" will then be displayed when the total time above set point $+1^{\circ}\text{C}$ reaches 2 hours.

Example d-21:

- This code "d-21" will be displayed when the total time below set point -2°C reaches 1 hour.
The code "d-22" will then be displayed when the total time below set point -2°C reaches 2 hours.

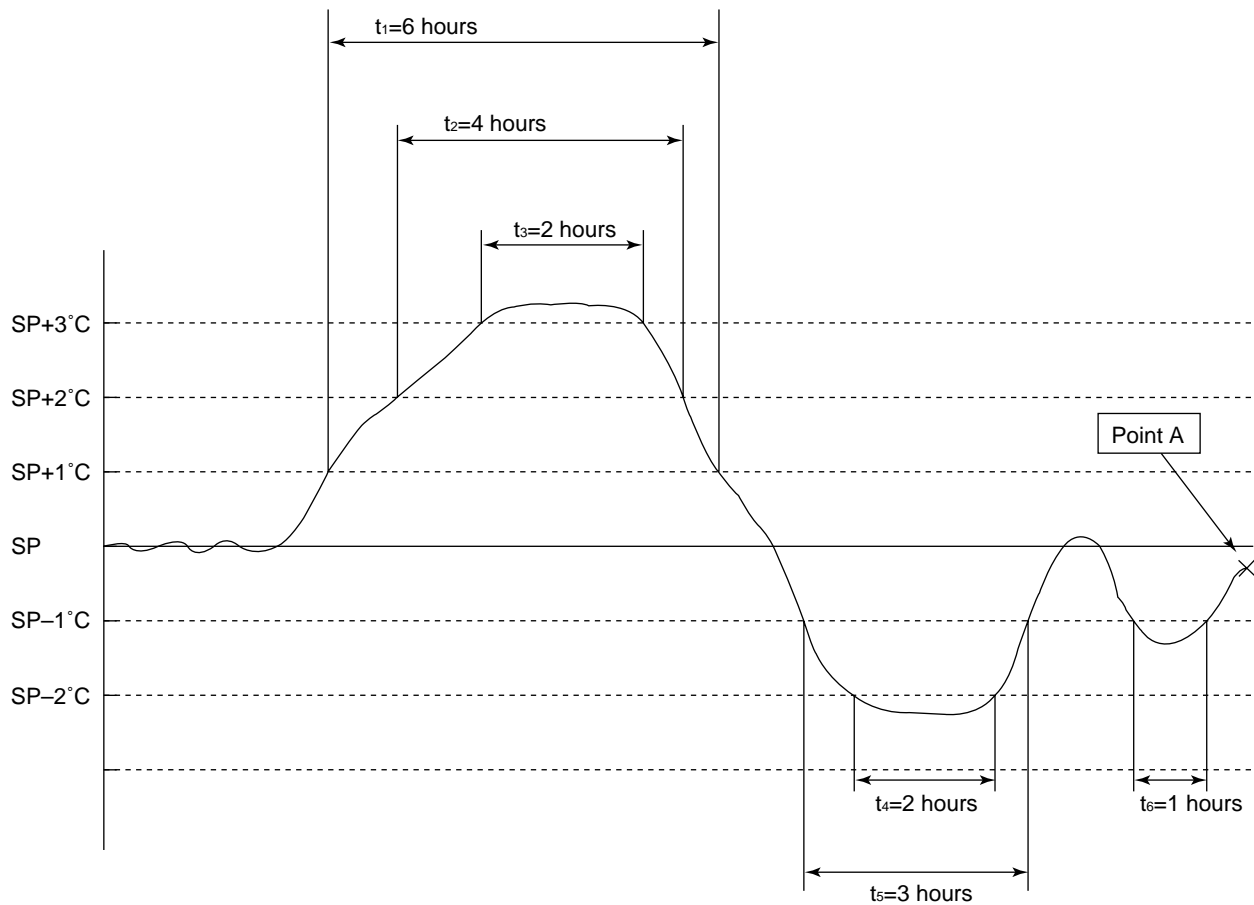

Example : If inside temperature was recorded above graph, controller shows the following "d code" when user check the code at "point A"

- d106 (above setpoint $+1^{\circ}\text{C}$ for 6 hours)
- d204 (above setpoint $+2^{\circ}\text{C}$ for 9 hours)
- d302 (above setpoint $+3^{\circ}\text{C}$ for 2 hours)
- d-22 (below setpoint -2°C for 2 hours)
- d-13 (below setpoint -1°C for 3 hours)
- d-11 (below setpoint -1°C for 1 hour)

Figure7

3.11 Communication modem

DECOS III d controller has function to transmit operation data through power line, if slave modem (Optional) is provided in control box. (Refer to Control box in 2.2.3)

The slave modem shall be complied with ISO10368. The following items can be monitored and/or commanded via master modem: (*1)

	Item	Description	
1	Inquiries (Remote monitoring)	<ul style="list-style-type: none">● Inside temperature and humidity● Set point temperature● Defrosting interval● Container No.● Logger header information● Alarm● Operation mode	<ul style="list-style-type: none">● Sensor data● Trip data● Alarm data
2	Commands (Remote control)	<ul style="list-style-type: none">● Set point temperature changing● Defrosting interval changing● Manual defrosting initiation	<ul style="list-style-type: none">● Container No. changing● Unit ON/OFF changing● Header information changing

(*1) According to the relationship among slave modem, Master modem and controller, items which can monitor and/or command are different. Please contact DAIKIN sales office if you have a specific item to monitor/command.

4. Service and maintenance

4.1 Maintenance service

4.1.1 Collection of refrigerant

- ① When release the refrigerant from the refrigerant system, be sure to use a refrigerant recovery unit to protect the ozone layer around the earth from depletion.
- ② Observe strictly all the environmental laws relating with to the country where the repair service is conducted.

4.1.2 Gauge manifold

(1) Attaching the gauge manifold

Place the quick joint against the service port and push it at section A until it clicks.

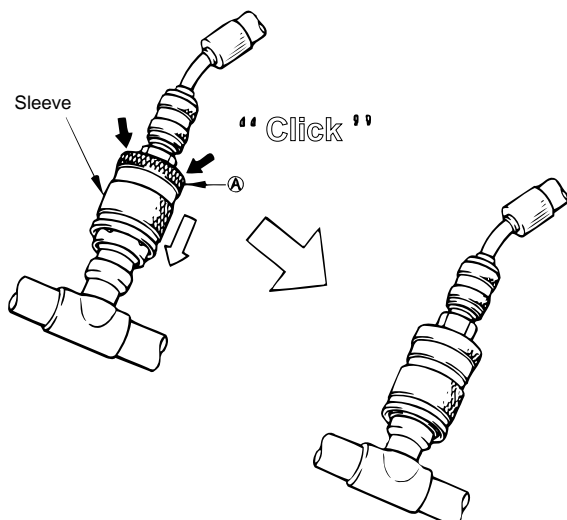

CAUTION

1. Use the pressure indicating function of the controller to check the working pressure as much as possible instead of using the gauge manifold in order to prevent foreign particles or moisture from mixing into the refrigerant system.
 2. Do not use any of the pressure gauge, gauge manifold, charge hose and charging cylinder which have been used for CFC12 in order to prevent refrigerant or refrigerant oil of a different kind from mixing. Use the exclusive tools for HFC 134a.
The service port of quick joint type is provided to make improved handling.
- ※ Quick joint system

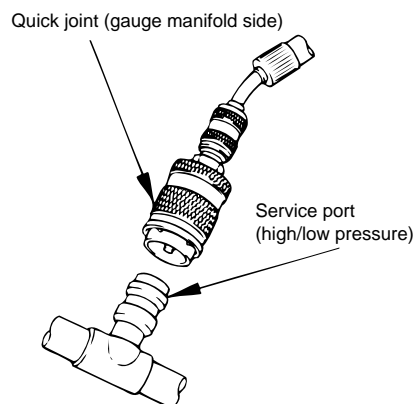

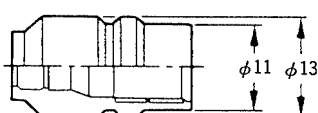
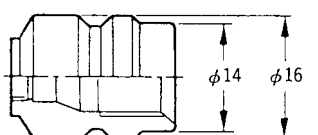
HFC134a (SAE quick joints)	
Low pressure side	
High pressure side	

Be sure to use the gauge manifold with the quick joints shown above.

●Caution on the service work

- ① Be sure not to bend the refrigerant pipe when pushing the quick joint during connection work.
- ② If the installation fails due to movement of the sleeve, try it again after returning the sleeve to the original position.
- ③ Set the discharge and suction stop valve handle at the half open (neutral position).
- ④ The remaining pressure in the charge hose may cause installation failure. In this case, try it again after relieving the pressure in the hose.

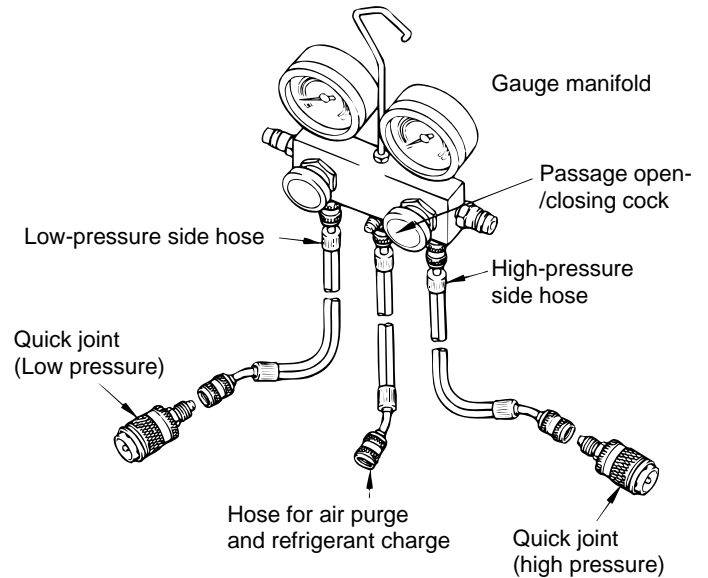

Structure of gauge manifold

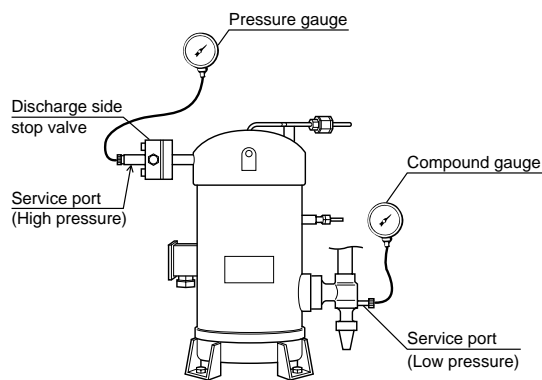
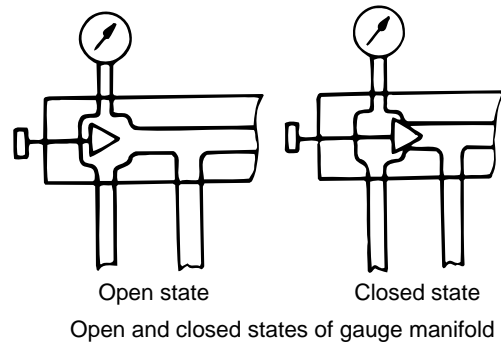

(2) Removal of gauge manifold

Holding the quick joint at **A**, pull the section **B** (sleeve) upward and remove the quick joint from the service port.

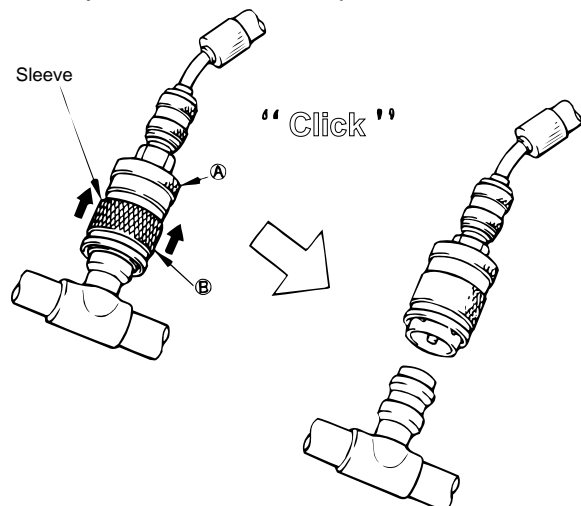

CAUTION

Be sure to attach the cap to the service port after the removal of the manifold.

4.1.3 Automatic Pump Down

An automatic pump down system is applied to the unit to prevent the unit from extra decrease of low pressure due to pump down operation or burning of scroll compressor due to a close stop valve.

(1) Controller operation

- ① Press **M** key twice during operation, and go to Automatic Pump Down Mode.

OFF	LED
P DOWN	LCD

- ② Select "ON" by using **△** or **▽** key, and press **↵** key to start the Automatic Pump Down.

ON
P DOWN

*No displayed in LED during Automatic Pump operation

P DOWN

*When Automatic Pump is completed, "GOOD" is displayed. and the unit stops.

GOOD
P DOWN

- ③ Turn the UNIT ON/OFF switch off.

○ Controller display

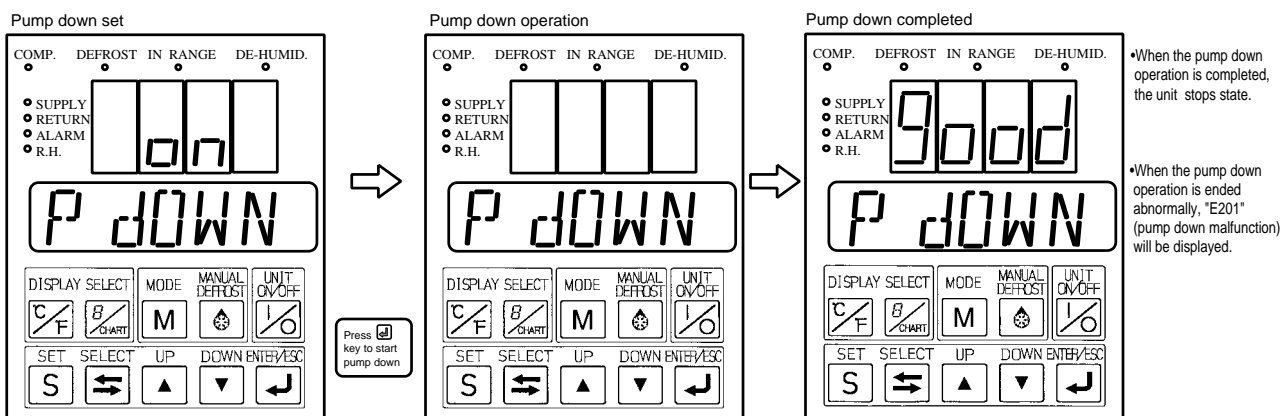

Fig. 2

After the automatic pump down operation, conduct the following jobs.

- ① Replacement of drier

As soon as the automatic pump down operation is complete, replace the drier in order to prevent air from entering the drier inlet/outlet piping. (Refer to 4.2.7 for detail.)
- ② Recovery of refrigerant

Conduct the automatic pump down operation in advance and, then, recover the refrigerant. (Refer to 4.1.4 (2), (3) for more detail.)
- ③ Refrigerant charge

Operate Automatic pump down when the specific refrigerant amount can not be charged due to the pressure balance. (Refer to 4.1.4 (4) for more detail.)

(2) Automatic pump down operation

Once the automatic pump down is started, all of the service works from refrigerant collection into the receiver, to the equalizing in suction piping system, can be executed automatically.

When "Good" is displayed, service works such as replacing the dryer, etc. can be conducted without any other operation.

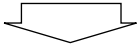
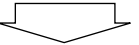
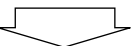
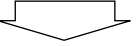
	①	②	③	④	⑤
	[Preparation] Turn on Automatic pump down.  Normal operation for 1 minute.	[Pump down-Twice] ②→③→②→③ Pump down start  Compressor stops at $LP \leq -55kPa$		[Pressure equalizing] Increase pressure to 0 ~300Kpa in low pressure side.	[Termination] EV full close  Termination  GOOD
COMP.	ON	ON	OFF	OFF	OFF
LSV	ON				
EV	ON	ON	ON	ON	ON (full close)
SMV	ON	ON	ON	ON	ON
ESV		ON→OFF			
DSV					
HSV				ON (1st)	
BSV					
ISV				ON (2nd)	
CSV					

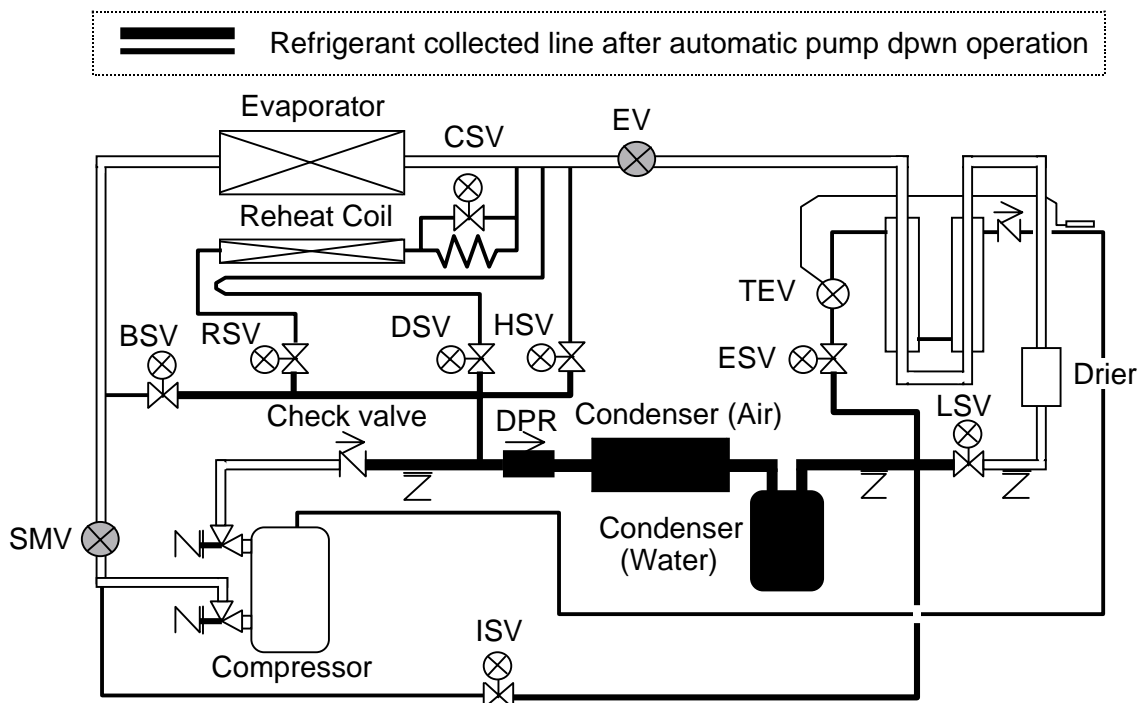

4.1.4 Refrigerant Recovery and Charge

Schematic diagram

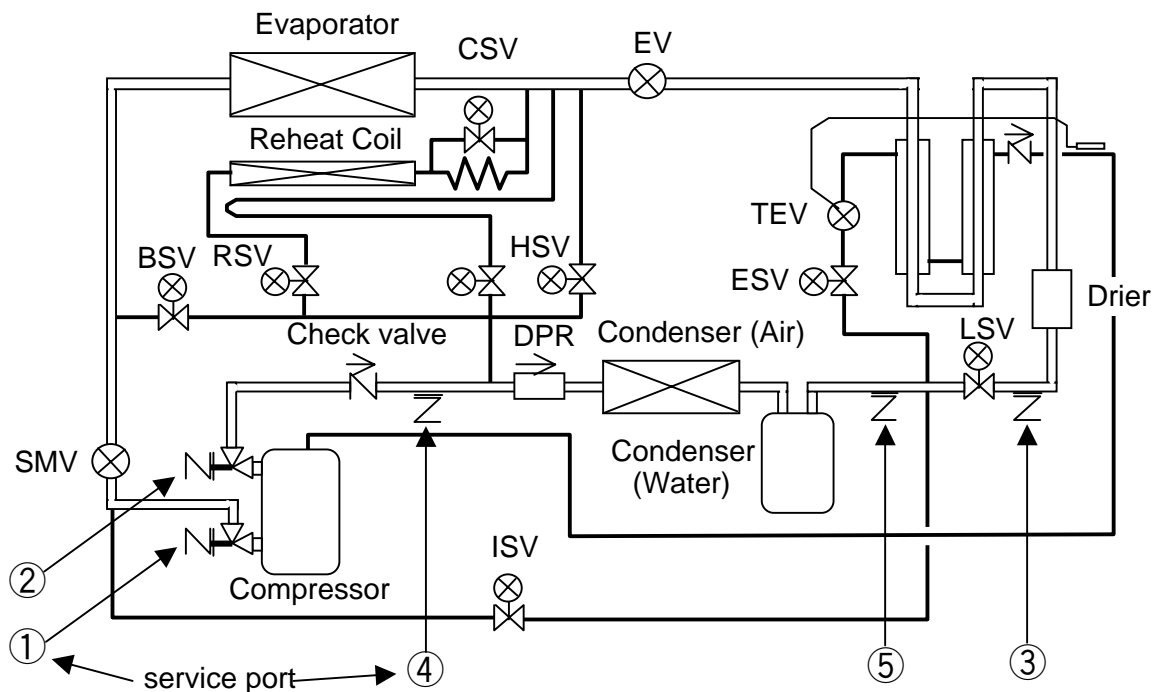

Service work		Service port	Remarks
Pressure Check	High pressure	②	Take care that the high pressure at the port ④ & ⑤ will be keeping for a while after the unit stops. (④ & ⑤ are in closed line between check valve and LSV.)
	Low pressure	①	
Refrigerant Charge (R134a : 5.4Kg)	[1] Refrigerant Recovery	⑤	Recover refrigerant from port ⑤ after operating Automatic Pump-Down first.
		④ & ⑤	Recover completely refrigerant left in the unit port ④ & ⑤.
	[2] Vacuum & Dehydration	④ & ⑤	After recovering, vacuum from port ④ & ⑤. *BSV,DSV,HSV & ISV are reversible in flow. *The connection at port ④ is same size as at ① for low pressure .
		[3] Liquid charging	⑤→③
③	1. Operate Automatic Pump-Down first and stop it using ON/OFF switch when the compressure stops during the Auto P.-D. operation. 2. Charge liquid refrigerant from port ③.		

(1) Operation Pressure Check

Check high pressure from the service port ② on the compressor discharge. Check low pressure from the service port ① on the compressor suction. Then stop valves is half open.

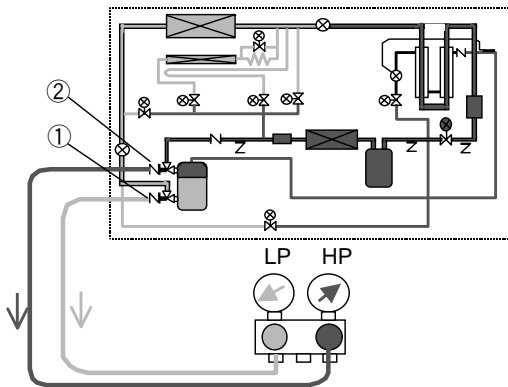

(2) Recovery non-condensable gas

If air or other non-condensable gas exists in the refrigerant circuit, it is accumulated in the condenser, which raises pressure in the condenser abnormally high and reduces the heat transfer ratio of the condenser surface resulting in a decrease of the refrigerating capacity. It is, therefore, very important to remove non-condensable gas.

If the discharge pressure is abnormally high and does not return to the normal pressure, inspect if air or any other non-condensable gas exists by the following procedure.

●Conduct automatic pump down operation (see page 4-3) and stop the unit after collecting the refrigerant into the liquid receiver.

Run the condenser fan by using the condenser fan check (see page 3-56) in the manual check functions, and wait until the condenser cooling air inlet/outlet temperatures become equal. If there is any difference between the saturated pressure corresponding to cooling air temperature and condensing pressure, then non-condensable gas exists. In this case, recover non-condensable gas as stated below.

- ①Conduct automatic pump down
- ②Then collect the gas from the service port ② on the compressor discharge side.

- ③Reading the pressure gauge, collect the non-condensable gas repeatedly until condensing pressure equals saturated pressure.

(3) Refrigerant Recovery

- ①Operate Automatic Pump Dpwn.
- ②Recover refrigerant from port ⑤.
- ③Recover completely refrigerant left in the unit from ports ④ & ⑤.

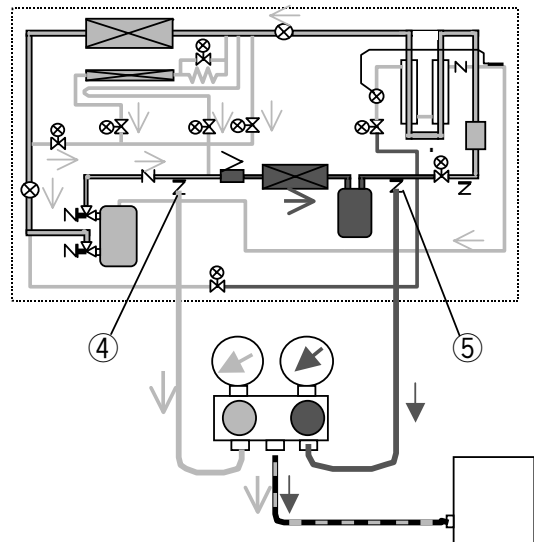

(4) Vacuum-dehydrating, and refrigerant / charging

If all the refrigerant has leaked out and air is intermixed in the refrigeration circuit, remove the cause of trouble and carry out vacuum-dehydrating. Then charge the specified amount of refrigerant.

[Required tools]

1. Refrigerant cylinder (content of 20kg) equipped with joint for HFC134a
2. Gauge manifold with quick joints
3. Weighing scale (up to 50kg)
4. Vacuum pump

(a) Vacuum dehydrating

After recovering, connect the vacuum pump to the service ports ④ and ⑤ at the liquid receiver outlet piping and discharge pressure regulating valve inlet, and then vacuum up to 76cmHg. Disconnect the vacuum pump, holding the refrigerant circuit in the vacuum state. However, if air enters in the refrigerant circuit, vacuum up the circuit to 76cmHg and then vacuum the circuit for another 2 hours or more.

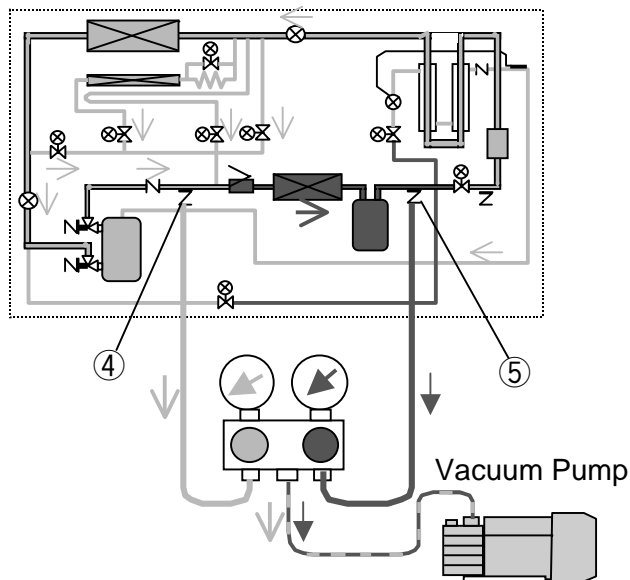

(b) Cylinder weight recording

Place a refrigerant cylinder on the weighing scale, and record the weight of the cylinder.

(c) Charging of liquid refrigerant

1. After vacuum & dehydration, charge the liquid refrigerant from port ⑤. (Approx. 50% of the specified amount will be charged.)

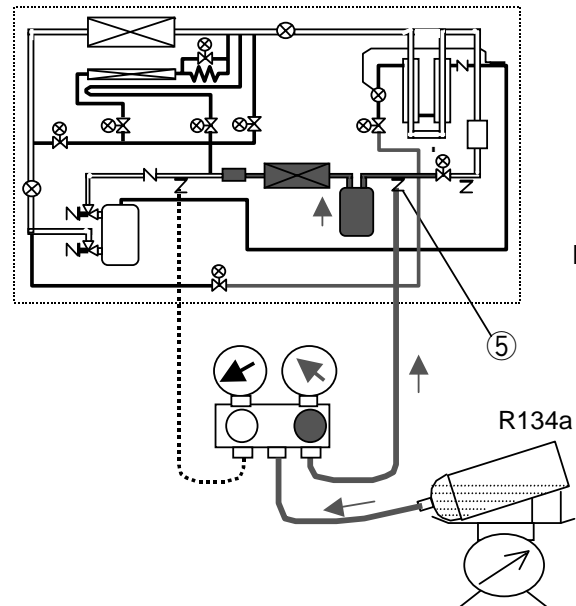

Figure 1

2. Replace the manifold gauge hose to port ③ and add the liquid refrigerant.

Then if it reached to the specified amount close the cock of the refrigerant cylinder.

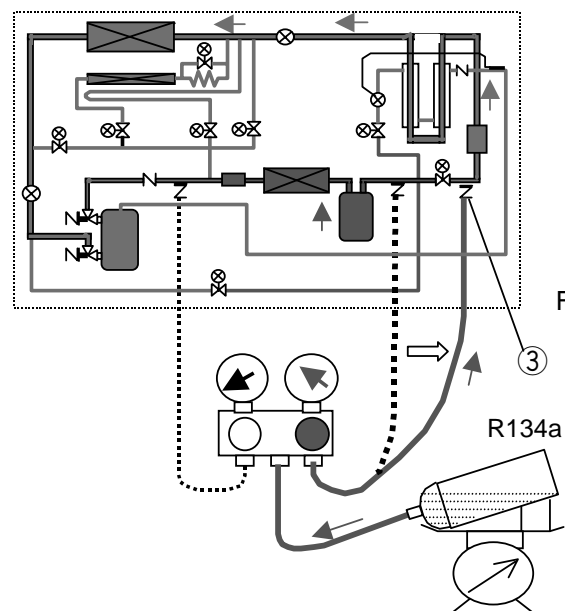

Figure 2

If it is not reached to the specified amount due to the pressure valance, close the cock of the ref. cylinder and go to next 3 & 4.

3. Operate Automatic Pump Down first.
When the compressor stops (※) during the operation, end the Auto. P. D. operation using Unit ON/OFF switch.
(※ The compressor stops twice during the Auto. P. D. operation. It is possible to end either at 1st stop or at 2nd stop.)

4. Open the cock of the ref. cylinder and add the liquid refrigerant from port ③.
Then if it reached to the specified amount close the cock of the ref. cylinder.



CAUTION

Carry out the operation check after the replacing and charging of refrigerant, then replace the drier.

4.2 Main components and maintenance

4.2.1 Scroll compressor

The compressor is of a hermetic scroll type with the built-in motor so that there are less places where refrigerant may leak. No refrigerant oil is required when the unit is new because it has been charged before delivery.

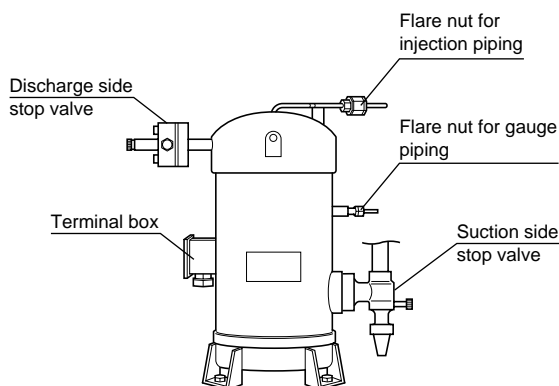

(1) Preparation of spare parts compressor

[Mode] JT224D-NYR
 * Precharged refrigerant oil DEPHNE FVC46D * 2.2L
 * Precharged non-moistured nitrogen gas

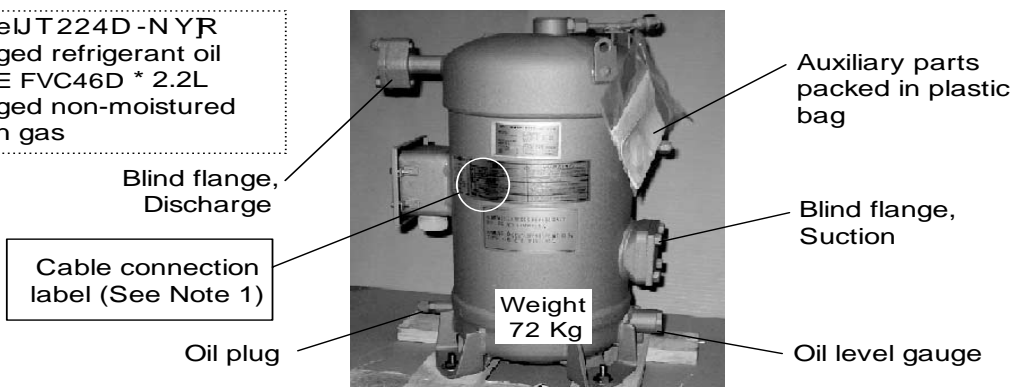

[Auxiliary parts]

Instruction card	Gasket, Suction	Gasket, Discharge	Packing tape for suction flange	Insulation tape for suction flange	Clamp band for insulation tape	Cable connection label for LXE10E-1
1 pcs	1 pcs	1 pcs	1 pcs	2 pcs	2 pcs	1 pcs
						(See Note 1)

Note 1. Stick the auxiliary cable connection label onto the label stuck on the compressor body. This is only for LXE10E-1.

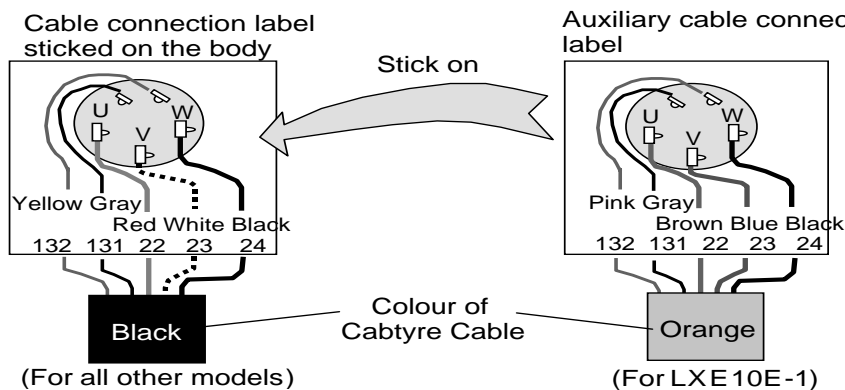

Note 2. Don't drop the precharged refrigerant oil out after removing the blind flanges.

CAUTION

The preparation of refrigerant oil is not required.
The compressor has been charge with the oil.

(2) Removal of compressor

- Recover refrigerant
1. Recover the refrigerant from service port ④ on discharge line and ⑤ at receiver/water cooled condenser outlet.
(Refer to the section 4.1.4 Refrigerant Recovery and charge)
 2. Close the discharge and suction side stop valves on the compressor.

- Disconnect cables and mounting bolts
3. Switch off the power.
 4. Open the terminal box cover and disconnect the cables.
 5. Remove the mounting bolts.

- Disconnect pipings
6. Remove the flare nuts for the injection piping on the compressor head and gauge piping on the body.

Attention !
Use double wrenches
when the flare nuts
are removed.

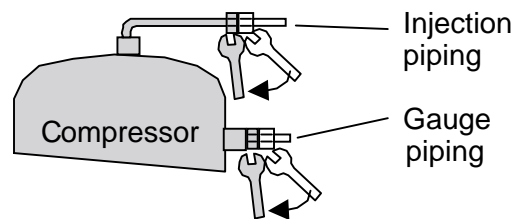

7. Remove the insulation tape fixed on suction flange and discharge flange.
8. Remove the bolts for suction and discharge flange.

(3) Installation of compressor

Connect pipings and fix mounting bolts

1. Before connecting pipings, insert and screw in the mounting bolts slightly.
2. Tighten the flare nuts for the injection piping and gauge piping on the body.

Attention !
Use doublewrenches when the flare nuts are tightened

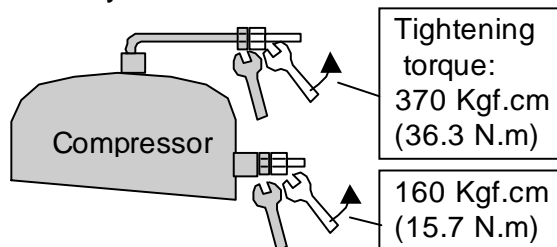

3. Fix the suction and discharge flanges using with the auxiliary gaskets and the bolts.
4. Tighten the mounting bolts.

Tightening torque
257 Kgf.cm (25.2 N.m)

435 Kgf.cm (42.7 N.m)

Connect cables

5. Check that stick the auxiliary cable connection label for LXE10E-1 is stuck onto the label for others on compressor body. This is only for LXE10E-1.
6. Connect the cables to the terminals.

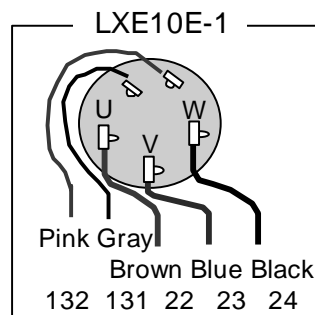

Attention ! Pay the attention to the cable connection. Incorrect wiring may run the compressor in wrong direction and may cause burn out.

Charge refrigerant

7. Open the discharge and suction side stop valves.
8. Vacuum and dehydrate from service port ④ and ⑤.
9. Then charge the refrigerant from service port ⑤ and ③.
(Refer to the chapter 4.1.4 Refrigerant Recovery and charge)
10. Check gas leakage especially at sunction/discharge flanges and flare nuts for injection piping/gauge piping.
11. Fix the auxiliary insulation tape and fix the auxiliary packing tape using clamp band to the sunction flanges.

12. Seal with silicon sealant around the flare nut for gauge piping.

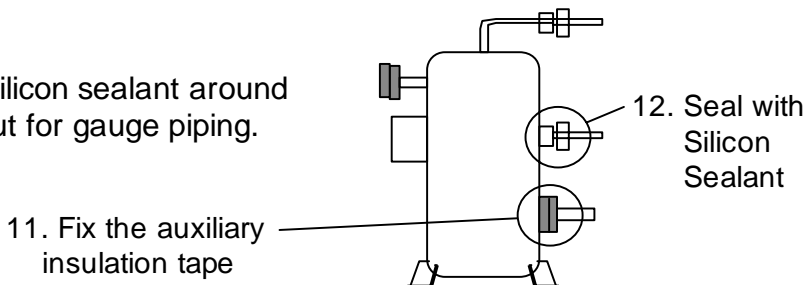

(4) Removal of excess refrigerant oil after compressor replacement

The oil plug, oil level gauge and "Removing oil label" are fitted on the spare parts compressor.

○ When the compressor is replaced to spare parts compressor, remove the excess refrigerant oil in the following procedure.

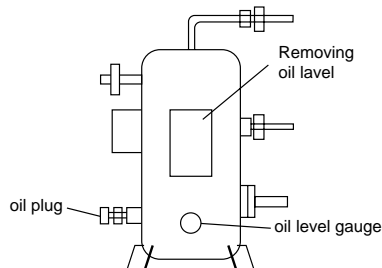

Preperation

1. First check again whether the discharge/suction side stop valves are opened and the cable connection at terminal is correct.
2. Connect gauge manifold hoses to the service ports on discharge /suction side stop valves.
3. Opeate the unit for about 5 minutes and stop it.

Return the oil to the comp-ressor

4. Operate the S-PTI (Short PTI) and stop at step of "P10".

- (1) Set the ON/OFF switch to ON
- (2) Go to PTI mode by pressing "Select" key immdiately for 3 seconds after all LED lighting OFF.
- (3) Sselect S-PTI using "△ or ▽" key and press "Enter" key, and S-PTI starts.
- (4) Stop the unit with ON/OFF switch when P10 is displayed on the LED.

<Function of step P06 & P08 before P10>

***P06 (HPS check)**

When the high pressure rises, the circuration rate of refrigeran increases and the oil is expecte to return to the compressor.

***P08 (Pump down check)**

The refrigerantcontained in the compressor oil is evaporated and seperated from the oil.

5. If the oil level can be seen on the oil level gauge, conduct the step 4 (Operate S-PTI and stop at P10.) for oil returning again.

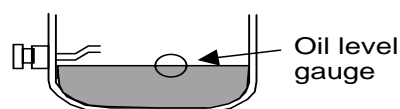

Remove the excess oil

6. Bypass the gas from high pressure side to low pressure side of gauge manifold and adjust the low pressure to 0 kPa or more.

7. Loosen the oil plug and remove the excess oil.

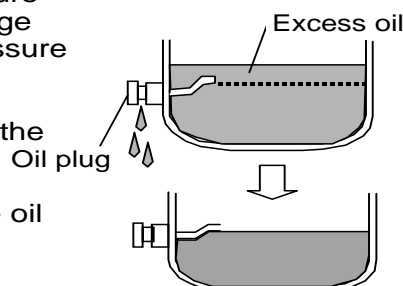

8. Close the oil plug when no more oil comes out.

9. Take off "Remove excess oil" level sticked on compressor body.

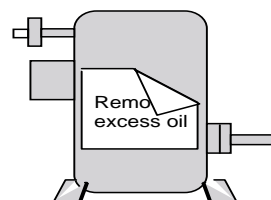

REMOVING EXCESS COMPRESSOR OIL IS NOT COMPLETED.
REMOVE EXCESS COMPRESSOR OIL. THEN TAKE OFF THIS LABEL

(5) Handling method of the stop valves

(1) Place of the stop valve and its kind

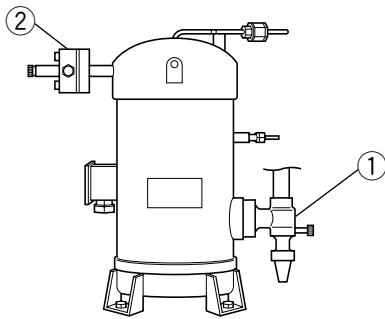

- ① Stop valve at compressor suction side
- ② Stop valve at compressor discharge side

[DISCHARGE SIDE STOP VALVE]

VSH22CAP

Pipe size 7/8" (22.2mm)

[SUCTION SIDE STOP VALVE]

VSH26Q-10S

Pipe size 1-1/4" (31.8mm)

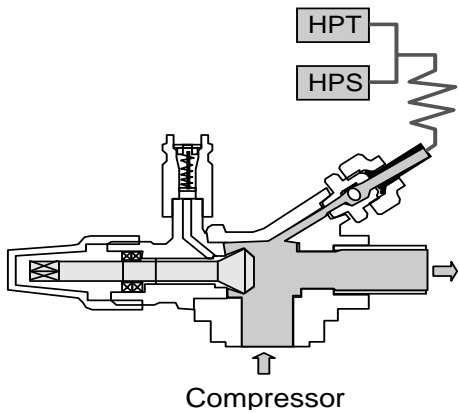

[FULL OPEN]

Normal opening during operation

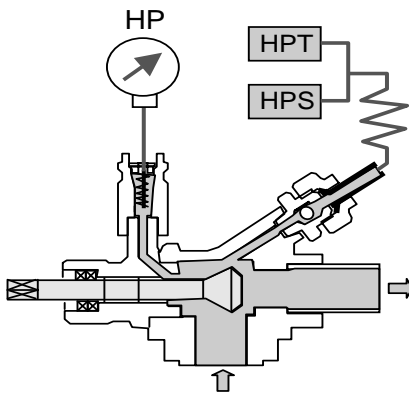
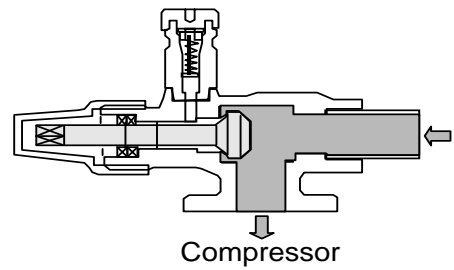

[HALF OPEN]

Pressure check during operation

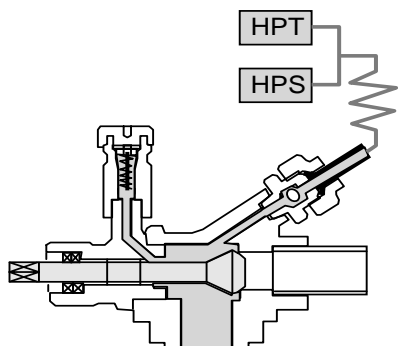
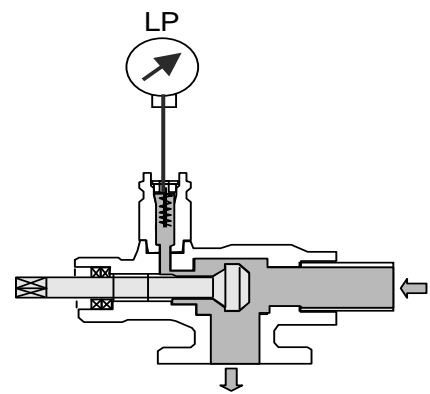

[FULL CLOSE]

Compressor replacement

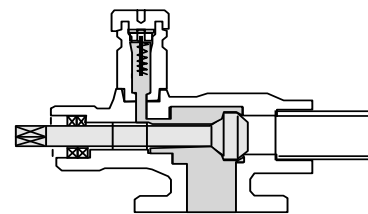

[Attention at valve shaft Handling]

1. Don't lose the "Ring Packing" when the "cap" is removed.
2. Loosen the Grand before closing or opening the valve shaft.
3. And fasten the Grand after opening or closing the valve shaft.

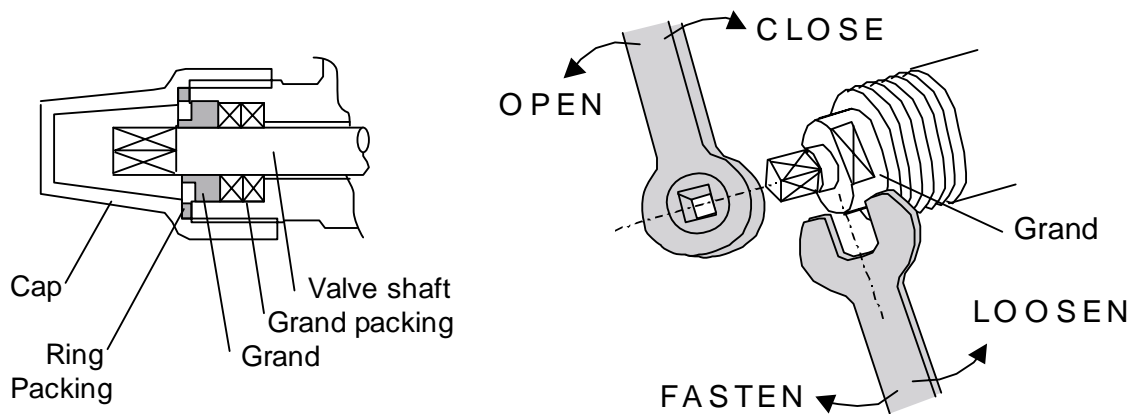

[Tightening torque]

	Discharge side stop valve			Suction side stop valve			Remarks
	N.m	kgf.cm	lb.ft	N.m	kgf.cm	lb.ft	
Valve shaft	20	204	14.8	35	357	25.8	for full close or full open
Grand	15	153	11.8	15	153	11.8	



CAUTION

Before operation, be sure to make sure the discharge stop valve and the suction stop valve are open. Operating the compressor with stop valves closed may burn out the compressor motor.

4.2.2 Fan and fan motor

(1) Specification

		Evaporator	Condenser
Fan	Model	Propeller fan	
	Size	440mm	300mm
Motor	Model	3-phase squirrel-cage induction motor	
	Output (60Hz) (Number of poles)	700/90W (2P/4P)	670W (4P)
	Bearing	Shielded ball bearing with rubber seal 6203WNC	Shielded ball bearing with rubber seal 620400NC-X

(2) Installation structure

a. Condenser fan and fan motor

Condenser fan and fan motor

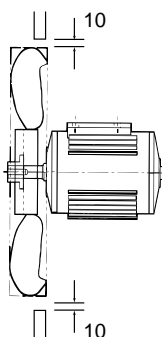

b. Evaporator fan and fan motor

Evaporator fan and fan motor

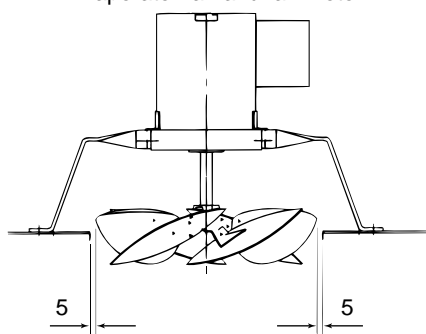

(3) Replacement procedure

1) Condenser fan

Remove the fan grille and the fan guide, and loosen the two hexagonal sets of screws on the boss of the fan, then pull the fan forward out.

※If the boss is stuck to the motor shaft, use the bearing drawing tool on the market to pull out the fan.

● How to use bearing drawing tool on the market.

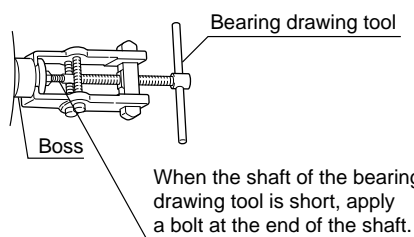

2) Condenser fan motor

- ① Remove the condenser fan.
- ② Disconnect the fan motor cable from the magnetic switch in the control box.
- ③ Remove the fan motor mounting bolts, and replace the motor.
- ④ Install the fan and connect the cable.
- ⑤ After replacement, confirm that the fan is not in contact with the fan guide. (For checking, rotate the fan by hand.)

3) Evaporator fan

Loosen the two sets of screws on the boss portion of the fan, and pull the fan downward out.

※ If the boss is stuck to the motor shaft, use a large spanner as shown below.

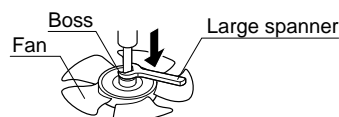

4) Evaporator fan motor

- ① After removing the fan at item 3), disconnect the fool proof wire connection.
- ② Remove the motor mounting bolts. (Do not remove the motor mounting base.)
- ③ After replacing the motor, connect the wiring with fool proof wire connection.
- ④ Install the fan.
- ⑤ After replacement, make sure that the fan is not in contact with the fan guide. (To check, rotate the fan by hand.)



CAUTION

Apply the locking agent on the screws of the fan to prevent from loosening. Otherwise, fan may drop from the motor.

4.2.3 PT and CT board (EC9756)

Two function of the measuring device and protector are integrated on this printed-circuit board. This board works as an interface between the main circuit (high voltage) and the controller.

(1) Function

Name	Content
Current measurement (CT1, CT2)	AC 0 to 50A (50/60Hz)
Voltage measurement (PT1, PT2)	AC 150 to 600V (50/60Hz)
Compressor overcurrent protection	Unit with 400V only : 26.0A Unit with 200V and 400V: 15.0A
Phase sequence detection	The phase sequence is detected by sending the voltage waveform to the controller.

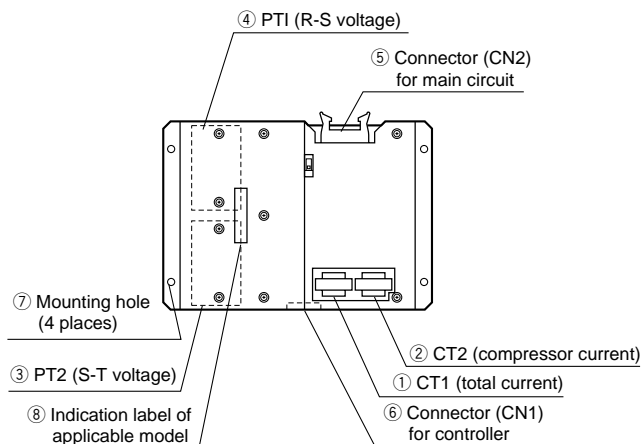

(2) Pre-assembly work

Before installing the PT/CT board (spare parts), cut jumpers and remove the mounting plate for the over current setting.

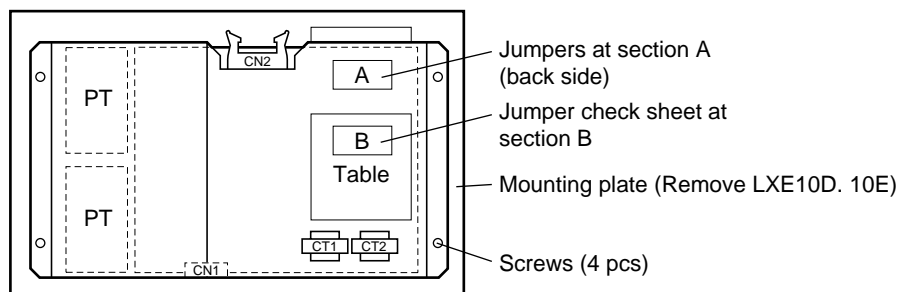

(2-1) Overcurrent setting

Cut jumpers at section A according to the following chart in order to make the over current setting.
Example: over current setting for 10Hp single power

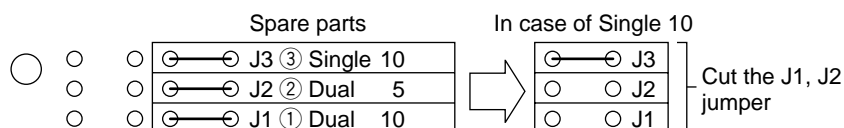

(2-2) Indication of check marks

After cutting jumpers, indicate check marks on the table B.

CASE	Type	Jumper			Check
		J1	J2	J3	
1	Dual 10	○	○	○	
2	Dual 5	○	○	○	
3	Single 10	○	○	○	✓

Table A

Table B

(2-3) Removal of mounting plate

Check the following table to see if the mounting plate should be removed. If the mounting plate must be removed, remove the four screws and dismount the mounting plate.

Over current setting and removal of mounting plate

Model		Spare parts	LXE5C	LXE10C	LXE10D	LXE10D LXE10E
Type		—	Dual 5HP	Dual 10HP		Single 10HP
Over current setting value		—	8.5A	15A		26A
Jumpers	J3					
	J2					
	J1					
Mounting plate		Provided	Not to be removed	Not to be removed	To be removed	To be removed

: Cut jumper

: Do not cut jumper

(3) Replacement procedure

CAUTION

Be sure that the main power is disconnected.

- ① Disconnect the wires routed via CT1 and CT2 from the terminals.
※At this time, take care to prevent CT1 and CT2 from being damaged.
- ② Disconnect the connector (CN1) for the controller and the connector (CN2) for the main circuit.
- ③ Remove four mounting nuts.
- ④ After replacing the PT and CT board, connect the lead wired in reverse order of the above removal procedure.
- ⑤ After checking the wiring once, test-run the system to verify that no trouble is found.

4.2.4 Electronic expansion valve

- Model Coil : EBM-MD12DM-1
Body : EDM-B804DM-1

This unit adopts an electronic expansion valve. The electronic expansion valve controls the optimum refrigerant flow rate automatically, using the temperature sensor at the evaporator inlet and outlet pipes.

In case of emergency including controller malfunctions, refer to the chapter of troubleshooting, section 6.4, Emergency operation.

(1) Replacing the coil

- ① Cut the binding bands which fasten the heat shrincable tube and the lead wires.
- ② Disconnect the lead wire connector from the heat shrincable tube.
- ③ Loosen the lock nut, then remove the coil from the body.
- ④ Install a new coil. Apply the small amount of "Lock-tight" to seal surface and screw of EV body (Don't apply too much "lock-tight".) The tightening torque for installation is 13.7 to 15.7 N · m (134 to 164kgf · cm).
- ⑤ Seal the lead wire and connector with butyl rubber tape. Restore the binding bands and the lead wire connector into the original state.
- ⑥ After replacing, carry out refrigerant leakage check, and make sure that there are no leaks.

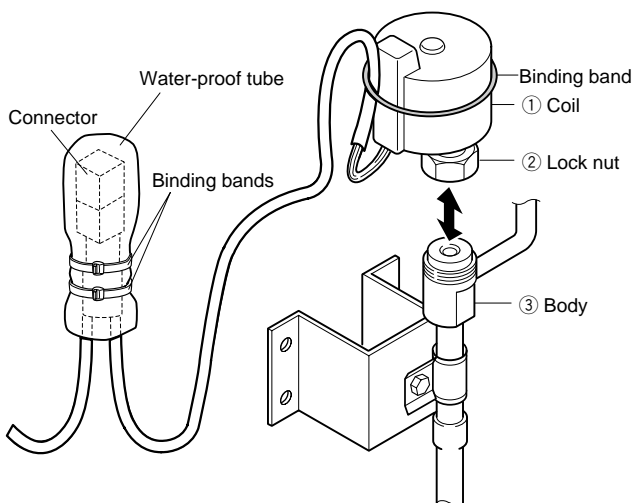

(2) Replacing the body

- ① Loosen the lock nut, then remove the coil.
- ② Remove the hexagonal head bolts, and cut the pipe on the body, then remove remaining pipes from brazing parts.
- ③ Connect a new body to the pipes. Be sure to conduct brazing work while cooling the body below 120°C (248°F) by using wet cloths.
- ④ Fix the body to the mounting base.
- ⑤ Remove the cap, and mount the coil. Apply the lock-tight to circumference of seal surface and screws for EV body. Do not apply too much lock-tight.

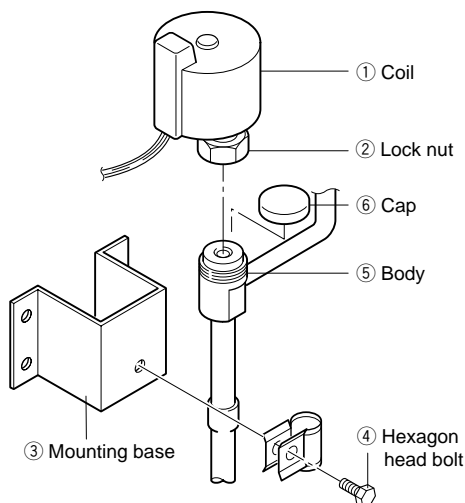

- ⑥ Apply a silicon sealant to the lock nut section.

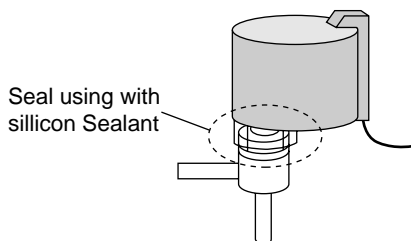

- ⑦ Clamp the lead wire to EV coil body. The edge of the wire protection vinyl tube shall be faced downward to avoid water coming into wire.

4.2.5 Thermostatic expansion valve (TEV)

● Model : VTX-3410DMS

This is an internal equalizer type of thermostatic automatic expansion valve and installed at the inlet to the heat exchanger (i.e., Economizer), which is used to detect the superheated degree of outlet refrigerant of the heat exchanger (Economizer) and make automatic adjustment of optimum refrigerant amount in response to operation conditions.

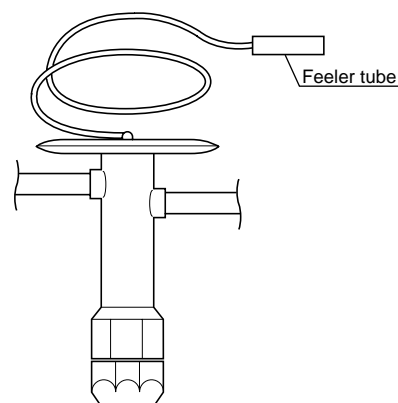

(1) Replacement procedure

- ① Remove the feeler tube and fixing bracket from the valve.
- ② Cut the pipe on TEV, then remove remaining pipes from brazing parts.
- ③ Connect a new TEV to the pipes. Be sure to conduct brazing work while cooling TEV below 120°C (248°F) by using wet cloths.
- ④ Reinstall and fix the feeler tube and capillary. As shown in the figure below, install the feeler tube directly above the pipe.

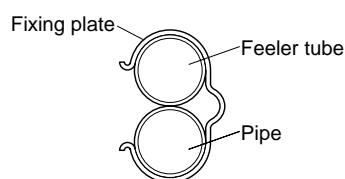

- ⑤ Cover the capillary tube with the heat shrinkable tube.

4.2.6 Suction modulation valve

The flow rate of suction gas is controlled between 3 to 100% by a stepping motor in order to conduct capacity control operation.

1. Replacing the coil

● Coil removing procedure

- (1) Disconnect the SMV lead wire connector ① from the inside of control box.
 - ① from the inside of control box.
- (2) Cut the binding band ③ at the upper rubber cover ① and lower rubber cover ②, then remove the rubber cover ①.
- (3) Remove the hose band ⑤ located above the coil ④ with screw driver.
- (4) Remove the coil ④ and the lower cover assembly ②.

● Reinstalling of coil

- (1) Mount the lower rubber cover assembly ② and the coil ④.
 - Note 1) Engage the dimple ⑧ of coil bracket ⑦ with the dimple ⑨ of coil ④, and adjust the angle.

Since the angle adjustment is important for control of suction modulating value, carry out the adjusting accurately.
 - Note 2) Set the hose band ⑤ with screw driver
 - Note 3) torque is $1 \pm 0.05 \text{ N} \cdot \text{m}$ ($10.2 \pm 0.5 \text{ kgf} \cdot \text{cm}$).

Be careful not to set the band at an angle.
- (2) Replace the upper rubber cover ①
 - Note) Set the engaging section of upper cover to fit with the rim of lower rubber cover ⑩.
- (3) Place the binding band ③ to fit the upper and lower covers
 - Note 1) Fastening is 100 to 140 N (10.2 to 14.3 kgf).
 - Note 2) Set the buckle of lower binding band within the range of $\pm 70^\circ$ on the left side and right side of the centre line at the front of valve.
 - Note 3) Fix the lead wire carefully so that water does not enter into its protecting tube ⑪. (Fix lead wire with binding band.)
- (4) Connect the connector of lead wire ① to the inside of control box.

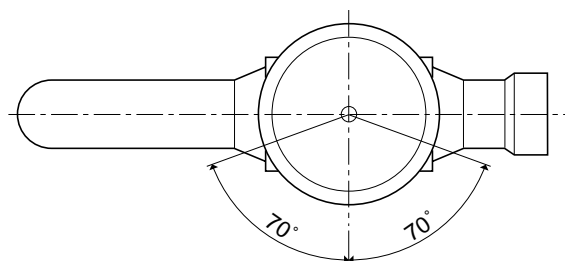
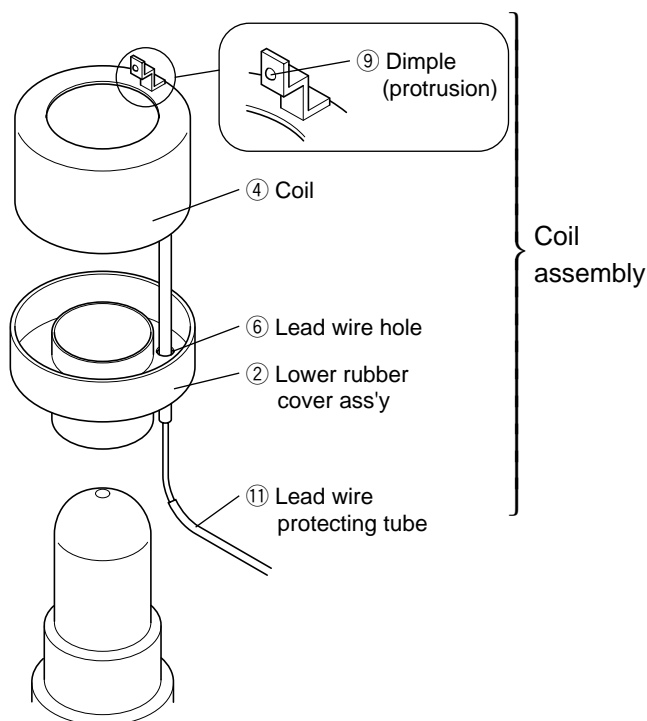
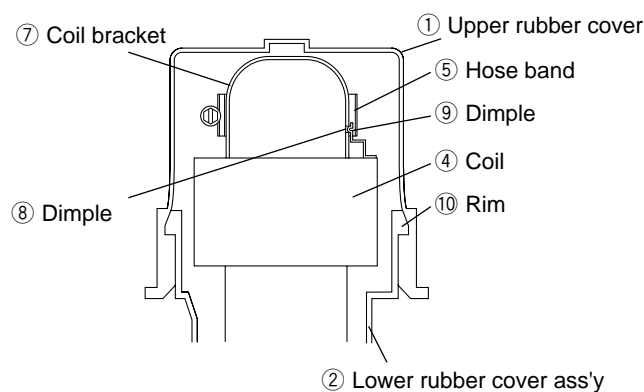
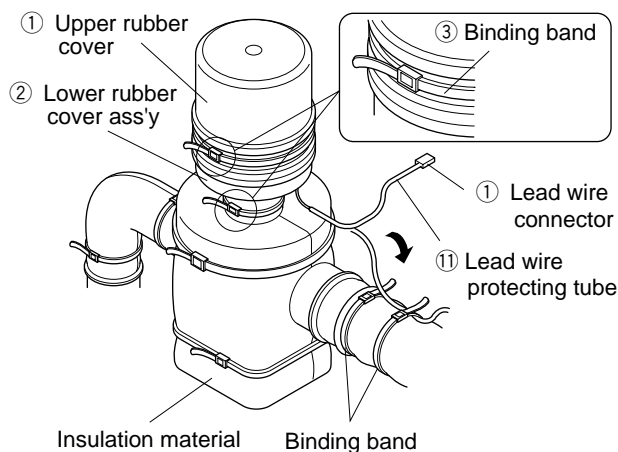

2. Replacement of body

- (1) Remove the coil. Refer to the section 1.
"Replacing the coil" for removing procedure.
- (2) Remove the heat insulator ① for the SMV after cut the binding band ②.
- (3) Heat up the brazed joint on the piping of SMV body to disconnect the pipe at brazed section.
- (4) Assemble piping of the SMV body, and conduct brazing while keeping the temperature of lower body of SMV below 120°C (248°F) by covering the body with wet cloth.
Note) When brazing, to keep the temperature of body, including value body, coil, lead wire, etc. below 120°C by supplying water.
In this work, be sure to prevent water from entering into the lead wire protection tube.
- (5) Install the heat insulator ① and fasten it with banding band ②.
- (6) Install the coil. Refer to the section 1.
"Replacing the coil" for removing procedure.

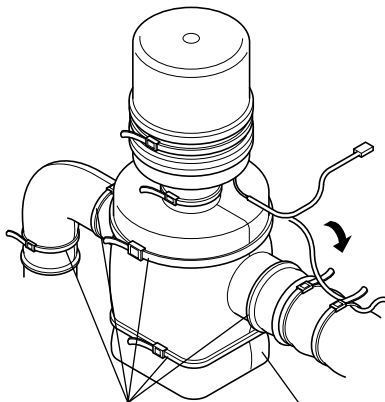

② Banding band ① Heat insulator

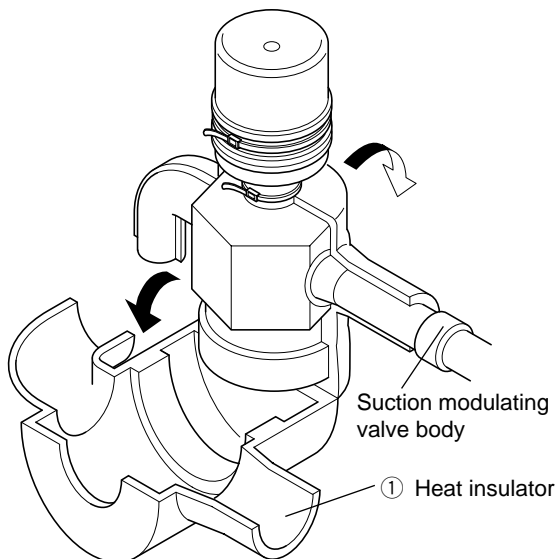

Suction modulating valve body

① Heat insulator

4.2.7 Drier

The drier automatically absorbs moisture in the refrigerant while it is circulated. It also commonly works as a filter to remove dust in the refrigerant. Replace the drier if it does not absorb moisture or if it is blocked. When installing the new drier, follow the directions given on the label and do not make any mistake about the flow direction of the drier.

(1) Replacement procedure

- ① Conduct **the automatic pump down** to collect the refrigerant in the liquid receiver. Refer to page 4-3 and 4-4 for the automatic pump down.
- ② Then, quickly replace the drier with a new one after loosening the flare nuts on the inlet and outlet side of the drier.
- ③ When the flare nuts are loosened, if no sound of gas refrigerant leakage is detected at the flare nut section, then air mixing into the refrigerant is suspected. In this case, conduct vacuum-dehydrating from the quick joint located at the inlet side of drier.
- ④ After completing of the replacement of the drier, be sure to conduct refrigerant leakage test to confirm that no refrigerant leakage is occurring.
- ⑤ Check on the green colour of the liquid / moisture indicator after system operation has started.
- ⑥ Apply a silicon sealant to the flare nut section.

Adhere some anti-corrosion tape to the flare nut section.

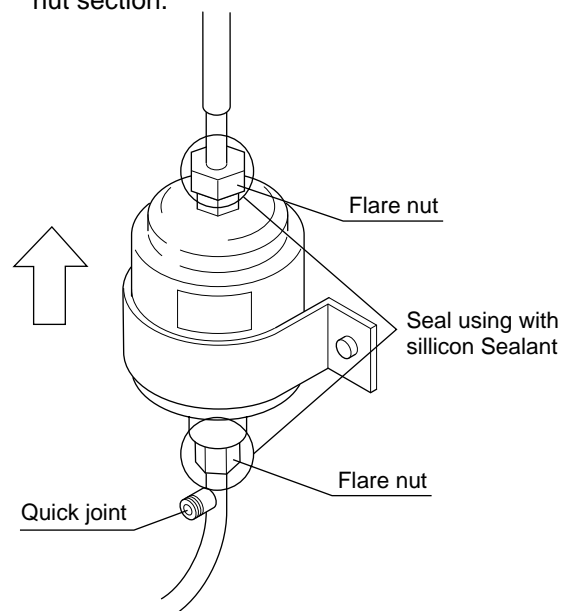

Flare nut

Seal using with silicon Sealant

Flare nut

Quick joint

4.2.8 Solenoid valve

Two kinds of solenoid valves are employed for the unit.

Coil is common and replacement procedure is also almost the same for all types of valves.

Valve name	Symbol	Valve type	Type of coil
Economizer Solenoid valve.	ESV	NEV-202DXF	NEV-MOAB507C
Injection Solenoid valve.	ISV		
Discharge gas by-pass Solenoid valve.	BSV	NEV-803DXF	
Liquid Solenoid valve.	LSV		
Defrosting Solenoid valve.	DSV		
Hot gas Solenoid valve.	HSV		
Reheat Solenoid valve.	RSV		
Capillary Solenoid valve.	CSV		

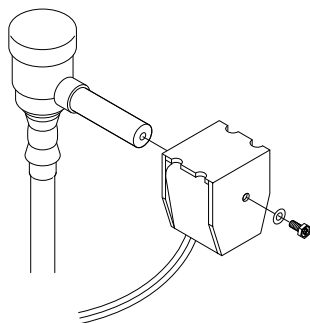

NEV-803DXF

Fig. 1

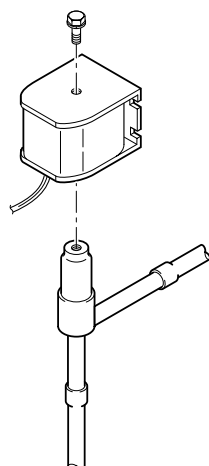

NEV-202DXF

Fig. 2

(1) Replacing the coil

- ① Remove the lead wire connector from the inside of the control box, and cut and recover the binding band which fastens the lead wire.
- ② Remove the hexagonal head bolt on the top of the coil to pull the coil out.
- ③ Replace the coil with a new one and restore the hexagonal head bolt, the binding band and connector on the original position.
When reassembling the coil, the tightening torque should be 2.9 N·m (30 kg·cm).

(2) Replacement of valve body

- ① Remove the hexagonal head bolt on the top of the coil to pull the coil out.
- ② Remove the hexagonal head bolt of the fixing plate, and cut the two pipes at the side of the valve body.
Disconnect the remaining pipes at the brazed joint sections.
- ③ Insert the new valve body into the pipe and conduct brazing while keeping the temperature of the valve body below 120 °C (248 °F) by cooling.
- ④ Install the coil and restore the hexagonal head bolt of the fixing plate and the connector into their original position.

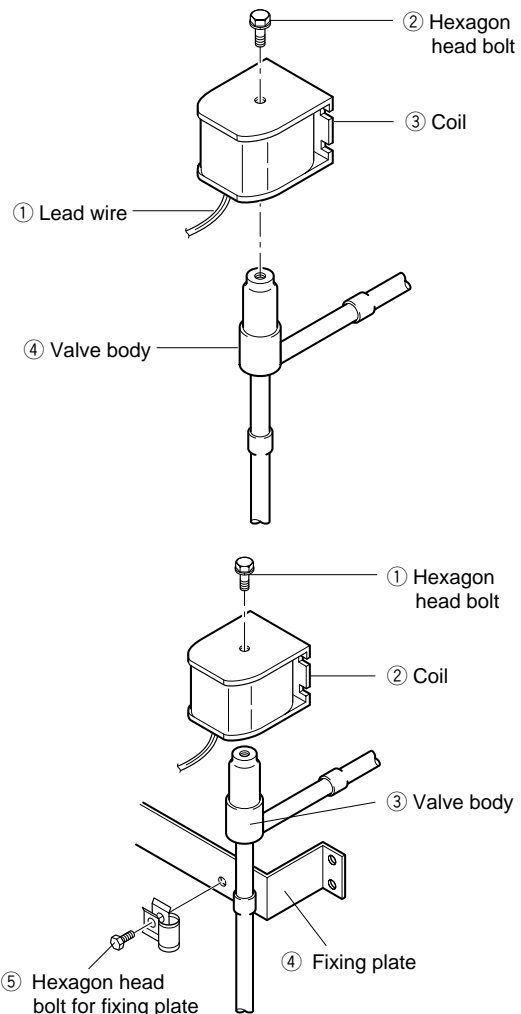

4.2.9 Discharge pressure regulating valve

- Model KVR15

(1) Replacing the valve

- ① Remove the protection cap to conduct brazing for the valve body.
Be sure not to turn the regulating screw inside the valve, since the pressure has been adjusted to 690 kPa (7.0 kg/cm²).
- ② When brazing, it is required to cool the valve body in order to keep the temperature of valve body below 140 °C by covering the body with wet cloth or the like.
- ③ After brazing work, set and tighten the protection cap.
The tightening torque should be 8 to 10 N·m.
Apply lock-tight, etc. on the screw section to avoid loosening of the cap.
- ④ After replacement, carry out refrigerant leakage check, and make sure there are no leaks.

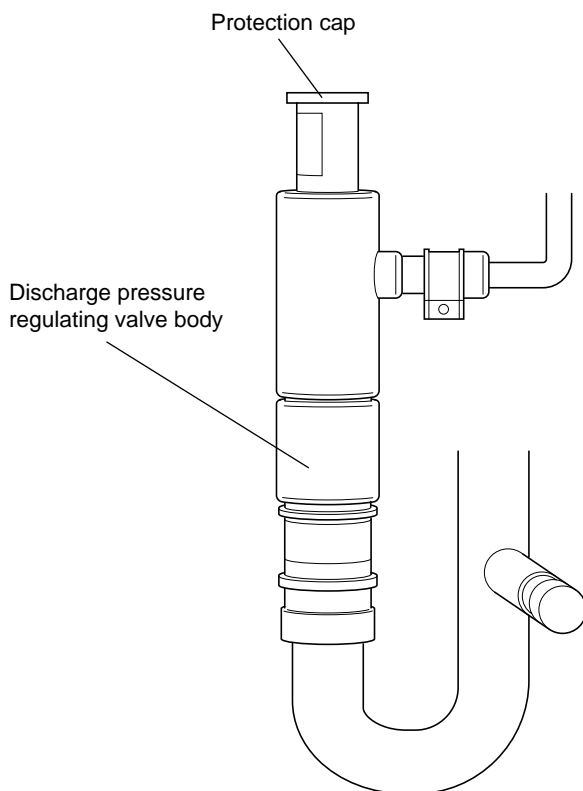

4.2.10 Check valve

- Model LCV(B)5

(1) Replacement procedure

- ① Remove the pipe clamp which fixes the check valve, then heat up the valve to disconnect the brazed joint.
- ② Install the new check valve taking care to install it in the correct direction, which is the same direction as the arrow shown in the label.
- ③ Conduct brazing while cool the center part of valve with a wet cloth to keep the temperature of the valve body below 120 °C (248 ° F)
- ④ After replacing the valve, carry out refrigerant leakage check, and make sure that there are no leaks.

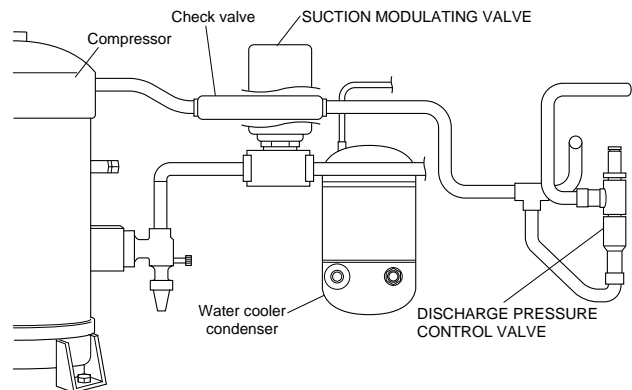

4.2.11 High-pressure switch (HPS)

- Model ACB-KB15
- Set point OFF : 2400kPa (24.47kg/cm²)
ON : 1900kPa (19.37kg/cm²)

When the refrigeration pressure of the unit rises abnormally, the compressor stops for safety. The HPS will be activated when the pressure exceeds the set point, as a result of trouble with the condenser fan.

(1) Replacement procedure

- ① Disconnect the lead wire from the control box.
- ② In order to prevent refrigerant from flowing out, disconnect the high-pressure gauge piping from the gauge joint (with check valve) **(A)** on the compressor side.
- ③ Remove the flare nut **(B)** and mounting screws of HPS on the casing at the left side of the compressor.
- ④ Replace the HPS. After tightening the flare nut **(B)**, tighten the flare nut **(A)**.
- ⑤ After tightening **(A)**, slightly loosen the flare nut **(B)**, remove air, and retighten **(B)**.
- ⑥ After replacing carry out the refrigerant leakage check, and make sure that there are no leaks.

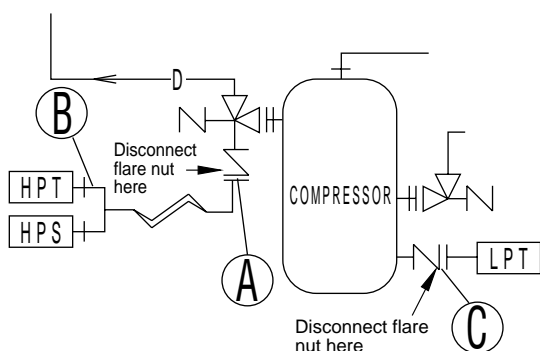

4.2.12 Low pressure transducer (LPT)

- Model SPCL02
- Colour indication: Low pressure transducer: Blue
Low pressure transducer: cable: White

The LPT is located in the refrigerant circuit.

The operating low pressure value is displayed on the controller indication panel.

(1) Replacing the transducer

- ① Disconnect the lead wire from the control box.
- ② In order to prevent refrigerant from flowing out, disconnect the low-pressure transducer piping from the gauge joint (with check valve) **(C)** on the compressor side.
- ③ Remove two screws on the clamp plate fixing low pressure transducer in place, and cut the binding bands.

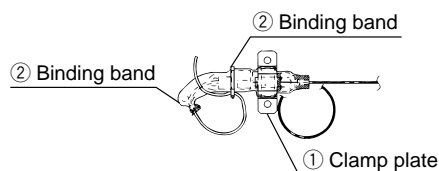

- ④ Remove the heat shrinkage tube, and disconnect the connector from the low pressure transducer, then disconnect the low pressure transducer from the flare nut.

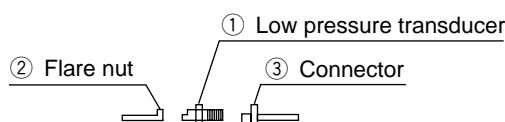

- ⑤ Insert the pressure transducer cable through the heat shrinkage tube, and connect the cable to the new low pressure transducer. If paint on the low pressure transducer is peeled off, apply clear lacquer.

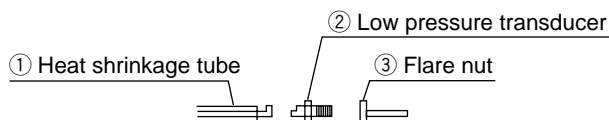

CAUTION

Do not expose the low pressure transducer to hot air of a dryer for excess time.

Otherwise, the transducer may be damaged.

- ⑥ Apply the heat shrinkage tube in the following position, then shrink it with hot air of a dryer.

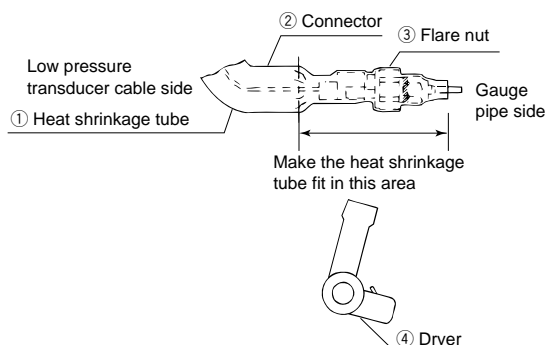

- ⑦ Apply sealer between the heat shrinkage tube and the flare nut. (Sealer :KE4898)

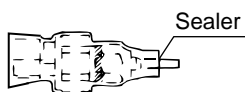

- ⑧ Fix the low pressure transducer with the clamp plate, and fix the cable with the binding band.

Fix the shrinkage tube end of the cable side downward for prevention of water entering into the tube.

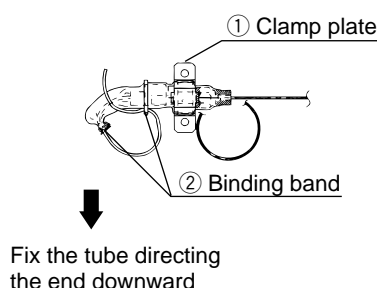

4.2.13 High pressure transducer (HPT)

- Model SPCH01
 - Colour indication: High pressure transducer: Red
High pressure transducer: cable: Red
- The HPT is located in the refrigerant circuit.
The operating high pressure value is displayed on the controller indication panel.

(1) Replacement procedure

The replacement procedure is the same as that for the low pressure transducer.
Make sure that the fixing position and the cable connection is correct.

4.2.14 Water pressure switch (WPS)

- Type: LCB-MB10
- Set value: OFF 98kPa (at 1.0-kg/cm² pressure)
ON 39kPa (at 0.4 kg/cm² pressure)

- This switch is used to select air-cooled operation or water-cooled operation. When the cooling water flows to provide an inlet water pressure of the set value or more, a contact in the switch turns OFF to stop the condenser fan, thus switching the unit to water-cooled operation.

(1) Replacement procedure

- ① Disconnect the WPS cable from the controller terminal board.
- ② Stop the cooling water pump and make sure no water pressure is applied. Then, disconnect the WPS.
- ③ Replace the WPS and wrap dry seal tape around the threaded part. Then, tighten a new WPS.

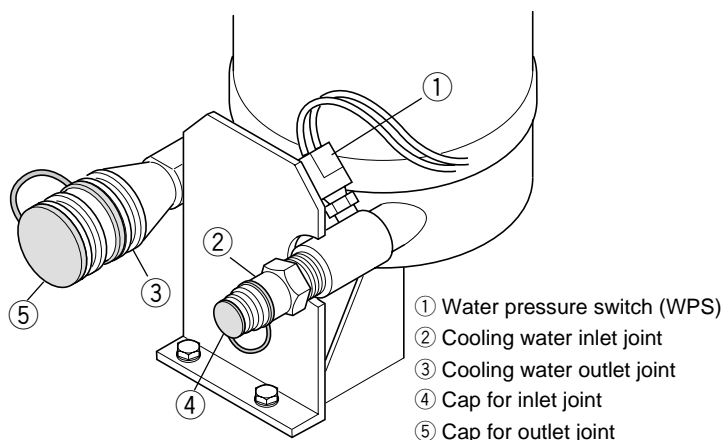

4.2.15 Humidity sensor

Please replace sensor every 2 years.
(The accuracy of sensor shall be kept within ±5%RH)

4.2.16 Ventilation opening detector (FA sensor)

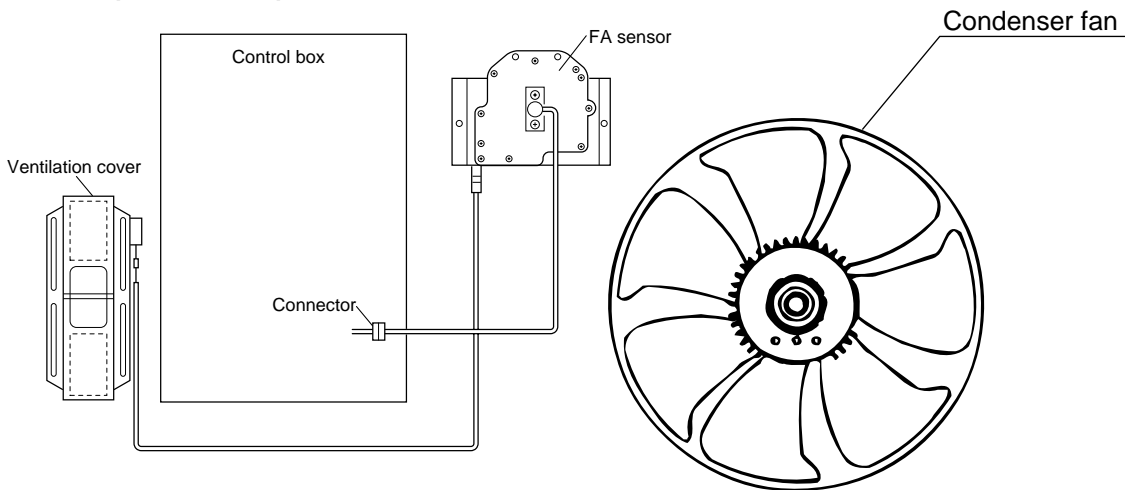

● Type: 5ZZ2157

This sensor has a main unit (i.e., wire winder block and position meter) and wire block. The wire tip is connected to the ventilation cover, which detects the opening degree of the ventilation port.

(1) Replacement procedure

- ① Disconnect the lead wire (with connector connected) in the control box.
- ② Remove the screw clamping the ventilation cover and the wire tip together.
- ③ Remove the screw fixing the main unit to the casing, and replace the one-piece sensor unit together with the wire.

Note)

Be sure to replace the one-piece sensor unit together with the wire.

- ④ After the replacement, seal the position meter fixing screw block on the sensor main unit with silicone sealant.

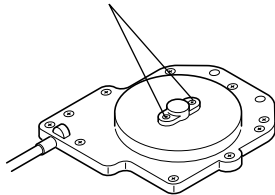

4.2.17 Air-cooled condenser and evaporator

This finned coil is compact and has uniform heat exchanging performance and high heat exchanging efficiency due to the adoption of corrugated fins.

● Washing of air-cooled condenser

Carefully flush the air-cooled condenser with fresh water after trip, although this type of condenser employs thick fins and electrodeposition coating for high corrosion resistance.

- For the maintenance of the air-cooled condenser, remove the fan grille, fan guide and temperature recorder box. For the maintenance of the evaporator, remove the rear panel of the evaporator.



Air cooled condenser

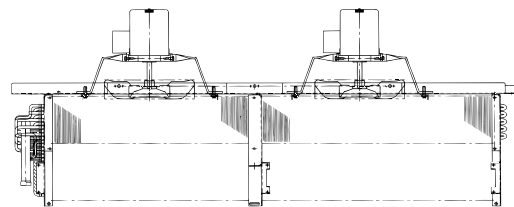

Evaporator

4.2.18 Water cooled condenser

This water cooled condenser is of shell-and-coil type that flows cooling water in the cooling pipes and refrigerant in the shell and adopt the cooling pipes with special designed fins. Thus making the condenser lightweight and compact.

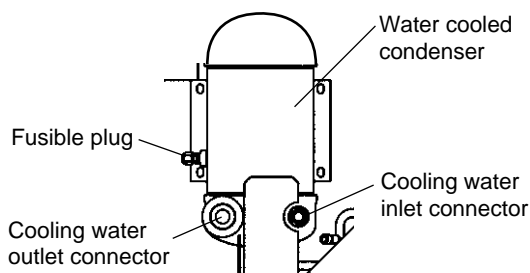

4.2.19 Fusible plug

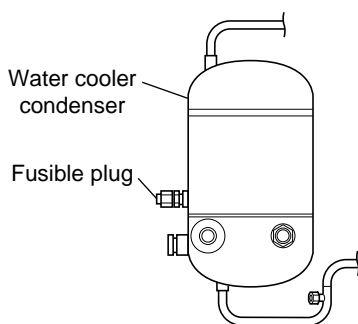

● Replacement of fusible plug

If pressure rises abnormally in the refrigeration circuit, the fusible plug is automatically activated, so, thoroughly check the possible causes if the fusible plug melts.

If the fusible plug is activated, the fusible alloy ① melts and refrigerant blow out (Melting point: 95°C ~100°C).

For replacement, ①-③ shall be replaced.

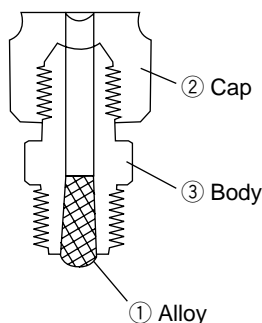

4.2.20 Liquid / Moisture indicator

This indicator permits checking of the flow of refrigerant and moisture content in the refrigerant.

(1) Moisture entering

The indicator indicates the moisture content by the colour at the centre of the window.

Check this indicator while the unit is operating.

Color	Conclusion
Green	Dry
Yellow	Wet (moisture entered)

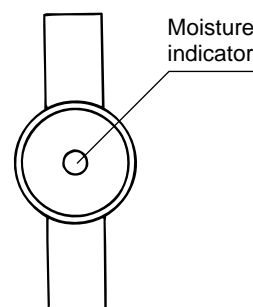

Note) 1. The indicator may appear yellow if it has been exposed to gaseous refrigerant for a long time.

2. The colour of the indicator must be checked after operation of a few hours.
3. The indicator is influenced by the temperature of the liquid refrigerant. At low temperatures, a long time is required for the indicator to change color.
4. To shorten the indication changing time, raise the temperature of the liquid refrigerant. (Block the air discharge grille of the condenser fan to increase the working pressure in order to raise the temperature.)

(2) Flow of refrigerant

When the moisture indicator is sealed with the liquid, bubbles will disappear on the moisture indicator.

- If a lot of bubbles are observed during pull-down and frozen operation, a refrigerant shortage can be suspected.
- Several bubbles may be generated soon after the operation start and chilled operation. However, it is not a refrigerant shortage.

4.2.21 Evacuation and dehydrating

After repairing the refrigerant system, vacuum-dehydrate the system before charging the refrigerant.

Vacuum-dehydrating is the process to make the circuit dry by purging the moisture (liquid) in the circuit to outside in state of vapor (gas) using the vacuum pump.

As the pressure lowers below normal atmosphere (760mmHg), the boiling point of water rapidly drops. If the boiling point drops beyond the atmospheric temperature, water will be vaporized.

Example: If the atmospheric temperature is 7.2 °C (45 °F), vacuum-dehydrating will be impossible unless the vacuum degree is lower than -752mmHg. For vacuum-dehydrating, it is important to select and maintain the vacuum pump.

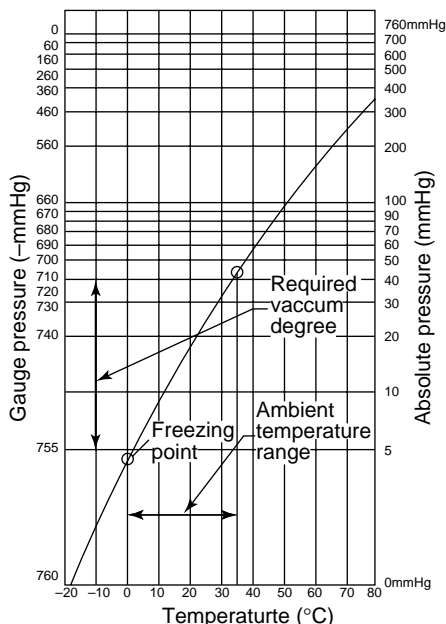

(1) Vacuum pump selection

Select a vacuum pump considering the following two points.

- ① Select a vacuum pump whose vacuum achievability is excellent.
(A vacuum degree of -755mmHg or lower can be achieved.)
- ② The displacement must be relatively large (approx. 40 ℓ /min. or more).
Before vacuum-dehydrating work, be sure to confirm that the pump achieves the vacuum degree of -755mmHg or lower by using the vacuum gauge.

Boiling point of water (°C)	Atmospheric pressure(mmHg)	Vacuum degree(mmHg)
40	55	-705
30	36	-724
26.7	25	-735
24.4	23	-737
22.2	20	-740
20.6	18	-742
17.8	15	-745
15.0	13	-747
11.7	10	-750
7.2	8	-752
0	5	-755

(Reference) Kinds of vacuum pumps and achievable vacuum degree

Type	Achievable vacuum degree Displacement	Application	
		For vacuum-dehydrating	For air exhausting
Oil rotary type (oil-necessary type)	-759.98mmHg 100 ℓ /min.	Applicable	Applicable
Oilless rotary type (oil-unnecessary type)	-750mmHg 50 ℓ /min.	Inapplicable	Inapplicable
	-759.98mmHg 40 ℓ /min.	Applicable	Applicable

Take care that this type is often used as the most convenient type.

With the pump of an oil rotary type, it is important to replace the oil and check the achievability every 1 to 2 months.

(2) Vacuum-dehydrating method

There are two method of vacuum-dehydrating of normal vacuum-dehydrating and special vacuum-dehydrating. In general, the normal vacuum-dehydrating is applied. If any moisture is enters the circuit, apply the special vacuum-dehydrating method.

[normal vacuum-dehydrating]

① Vacuum-dehydrating(first time)

Connect the gauge manifold to the service ports of the liquid line and the outlet of discharge pressure regulator. Run the vacuum pump for 2 hours or longer. (The achievable vacuum degree must be -755 mmHg or lower)

If a pressure of -755mmHg or lower can not be achieved even after pump operation of 2 hours, moisture or leakage may exist in the system. In this case, run the pump another hour or more. If a pressure of -755mmHg or lower can not be achieved even after operation of 3 hours or more, check for leakage.

Note: Evacuate the system from the service ports ④ of both liquid and outlet of the check valve ⑤, because the system is blocked on the way since the liquid solenoid valve is provided on the way of the system.

- ② Vacuum holding test
Hold the system at a pressure of -755mmHg or lower for 1 hour or longer, and confirm that the vacuum reading does not rise on the vacuum gauge. If it rises, moisture or leakage may exist in the system. However, take care not to leak air from the gauge manifold. If air enters, it is recommended to use the copper tube directly instead of gauge manifold.
- ③ Charging of refrigerant
After the vacuum-holding test, make the circuit vacuum again for approx. 10 minutes. Then, charge the specified amount of refrigerant through the service port on the liquid line using the charging cylinder.

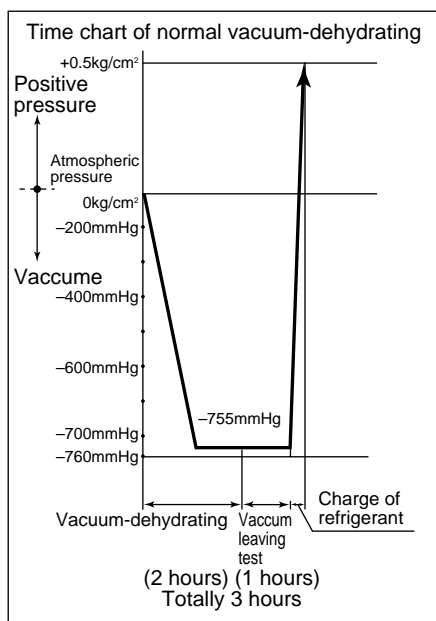

[Special vacuum-dehydrating]
This method is that the vacuum-breaking process with nitrogen gas is integrated one time or more in the same way as the normal vacuum-dehydrating process.

- ① Vacuum-dehydrating (first time) 2 hours
- ② Vacuum-breaking (first time)
Nitrogen gas is pressurized to 0.5kg/cm^2 from the service port on suction pipe. Since nitrogen gas breaks the vacuum, the effect of the vacuum-dehydrating is enhanced. However, if there is much moisture, it can not be removed by this method. Therefore, do not allow water entry or produce water during the refrigerant piping work.
- ③ Vacuum-dehydrating (second time)
Run the vacuum pump one hour or longer. (The achievable vacuum must be -755mmHg or lower.)
If pressure of -755mmHg or lower can not be achieved even after vacuuming of 2 hours, repeat step ② vacuum-breaking and ③ vacuum-dehydrating.
- ④ Vacuum holding test 1 hour } Same as normal vacuum-dehydrating
- ⑤ Additional charge of refrigerant } Same as normal vacuum-dehydrating

Note: Make sure to use nitrogen gas for vacuum-breaking. (If any oxygen gas is used, it may explode.)

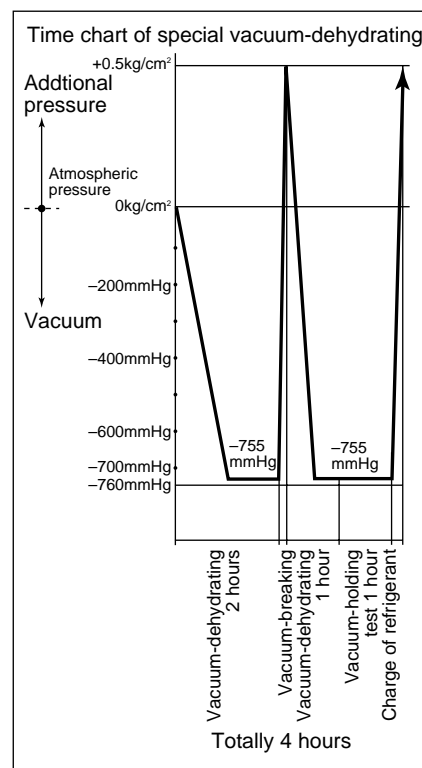

($1\text{mmHg}=0.0013\text{kg/cm}^2=0.133\text{Kpa}$)

5. Additional Devices

5.1 USDA transportation

If USDA receptacles and sensors (Optional) are provided to the unit, the unit can take USDA transportation. (Refer to arrangement of main component in 2.2.2.)

5.1.1 Type of USDA sensor/receptacle

Two types of sensors can be installed, according to the type of receptacles.

User should confirm the type of receptacles and select proper sensor in below table.

According to the model, the quantity of receptacle is different. (3 or 4)

Type	Receptacle	Sensor
1	T3107003	ST9702-1
2	HD10-3-96P	NTC type probe

*3 receptacles : USDA 1, USDA 2, USDA 3

4 receptacles : USDA 1, USDA 2, USDA 3, CTS (Cargo temperature sensor)

5.1.2 Initial setting

User should confirm initial setting of controller as below.

- 1) USDA transportation ; Initial setting mode at page 3-29.
Quantity of receptacles should be set
- 2) Type of USDA sensor
Type of USDA sensor should be set.

5.1.3 USDA sensor calibration

USDA requires sensor calibration every transportation and report each offset figure. Free-supply downloading software enable to assist this. Please refer to "Operation manual for Daikin Container Communication Software".

5.1.4 USDA transportation requirement

Cargo and refrigeration unit shall be required pre-cooling before cargo loading. As to position of USDA sensors and operation, please refer to the guidance of USDA.

5.1.5 USDA report

Free supply downloading software enables you to make document easily, which USDA local officer requires. In detail, please refer to "Operation manual for Daikin Container Communication Software".

●An example of installation of USDA receptacle inside

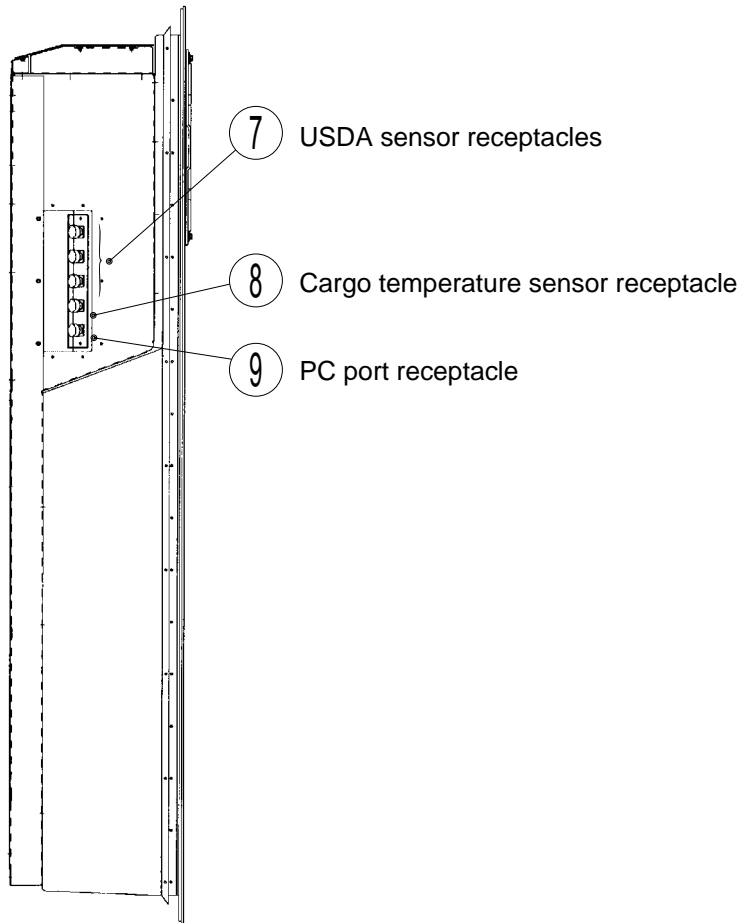

●USDA sensor (type 2)

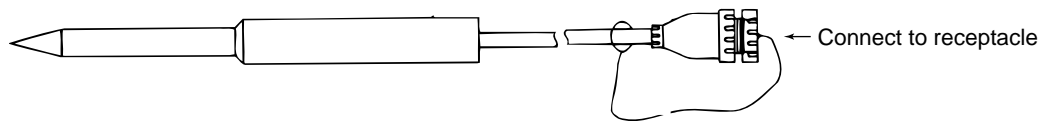

6. TROUBLESHOOTING

6.1 Refrigeration system and electrical system

If the unit does not work properly, refer to the following table to find causes of trouble and provide appropriate measures.

State	Malfunction occurrence	Abnormal point	Possible cause	
I unit does not operate	A. Neither evaporator fan, condenser fan nor compressor ran.	① No trouble with unit	Power failure	
			Equipment power supply: OFF	
			Disconnection of power plug	
			Poor contact of power plug	
		② Circuit breaker	Circuit breaker: OFF	
			Solenoid valve coil burned out or short circuit	
			Contacting coil burned out or short circuit	
		③ UNIT ON/OFF key	OFF or malfunction	
			④ Controller	Wire breakage in the control circuit transformer
		Fuse (10A) burned out		
Open phase (R or T)				
Shut down due to alarm generation				
⑤ Power transformer	Wire breakage or open phase			
B. Evaporator fan rotates, but condenser fan and compressor do not rotate.	No trouble with unit	ON/OFF control with frozen mode (Inside temperature is lower than SP.)		
		C. Condenser fan rotates, but evaporator fan and compressor do not rotate.	Overcurrent due to overload operation, etc.	
			D. Compressor rotates, but evaporator fan and condenser fan do not rotate.	Fan locked by foreign material
				Not-closing of protection thermostat contact point
			E. Compressor buzzes, but it does not operate.	① Compressor
Lock				
Low supply voltage				
Motor coil burned out or short circuit				
② Power transformer	Power transformer malfunction			
II Unit operates but soon stops	A. Unit starts but soon stops	① Activation of HPS within 30 seconds after compressor starting		High-pressure switch malfunction
			Compressor discharge side stop valve: closed	
		② Abnormal low pressure drop within 2 seconds after compressor starting	Liquid solenoid valve: closed	
			Electronic expansion valve: closed	
	③ Activation of electronic overcurrent protection devices, PT/CT board	Compressor suction side stop valve: closed		
		Overcurrent due to overload operation, etc.		
	④ Activation of compressor thermal protector	Overcurrent due to overload operation, etc.		
		B. Evaporator fan rotates, but condenser fan and compressor do not rotate.	① No trouble with unit	In ON-OFF control operation with frozen mode
	C. Condenser fan rotates, but evaporator fan and compressor do not rotate.			① Activation of high-pressure switch (Air cooled condenser type)
		Air entering in the refrigerant system		
Insufficient air flow rate in the air cooled condenser				
○ Condenser finned coil blocked				
○ Air passage blocked by foreign material				
○ Broken blade of condenser fan				
○ Condenser fan motor rotation failure				
○ Activation of condenser fan motor thermal protector				

State	Malfunction occurrence	Abnormal point	Possible cause
II Unit operates but soon stops	C. Condenser fan rotates, but evaporator fan and compressor do not rotate.	① Activation of high-pressure switch (Water cooled condenser type)	<input type="radio"/> Short circuit of condenser fan motor
			<input type="radio"/> Wrong installation of condenser fan
			<input type="radio"/> Reverse rotation of condenser fan
			Insufficient cooling water flow rate
			<input type="radio"/> Water-cooled condenser blocked with scale
		② Electronic overcurrent protection device, PT/CT board actuation	Overcurrent due to overload operation, etc.
		③ Abnormal low pressure drop	Electronic expansion valve: poor contact of connector
			Electronic expansion valve: incorrect opening
			Electronic expansion valve: blocked
			Suction modulating valve: blocked
			Dryer: blocked
		④ Abnormal discharge gas temperature	Hot gas solenoid valve: coil wire broken
			Injection solenoid valve: closed
Injection capillary tube: blocked			
High pressure increasing due to overload			
III Inside temperature does not drop.	A. Suction pressure is high	① Poor compression of compressor	Abrasion of scroll slide section
		② Hot gas solenoid valve	Valve leakage
		③ Defrosting solenoid valve	Valve leakage
		④ Discharge gas by-pass solenoid valve	Valve leakage
		⑤ Electronic expansion valve	Electronic expansion valve malfunction
			Poor contact of connector
	⑥ Injection solenoid valve	Valve leakage	
	B. Suction pressure is excessively low	① Liquid solenoid valve (Not opened)	Solenoid valve coil malfunction
		② Shortage of refrigerant charge	Refrigerant leakage
		③ Drier	Drier blocked with contamination
		④ Suction modulating valve	Coil wire breakage
			Disconnection of connector
		⑤ Electronic expansion valve	Valve blocked with moisture
Valve blocked with contamination			
Breakage of coil lead wire or disconnection of connector			
Lead wire breakage or miss-mounting of evaporator inlet or outlet sensor			
⑥ Evaporator		Electronic expansion valve malfunction	
	Abnormal frosting		
	Insufficient air flow rate in the evaporator		
	<input type="radio"/> Air passage blocked by foreign material		
	<input type="radio"/> Evaporator fan motor malfunction		
	<input type="radio"/> Evaporator fan damage or fall out		
<input type="radio"/> Air short circuit around the evaporator			
<input type="radio"/> Reverse rotation of evaporator fan motor			
C. Economizer circuit does not function	Economizer solenoid valve	Solenoid valve coil malfunction	
		Valve blocked with contamination	
		Thermostatic expansion valve is choked with moisture	
		Thermostatic expansion valve is clogged with contamination	
D. Defrosting is not initiated.	④ No trouble with unit	Gas in the feeler bulb of thermostatic expansion valve is leaked	
		① Manual defrost key	Poor contact of connector
		② Evaporator outlet sensor	Incorrect installation of sensor
		③ Defrosting solenoid valve	Valve blocked with contamination
			Valve coil malfunction
④ No trouble with unit	Defrost interval is set to 99 H (Demand/defrost setting)		

State	Malfunction occurrence	Abnormal point	Possible cause	
III Inside temperature does not drop.	E. Defrosting is operated frequently.	① No trouble with the unit	Excessive amount of moisture in cargo	
		② Defrost timer	Short setting timer	
IV Inside temperature does not rise (in the heating mode)	F. Refrigeration unit is normal	① Container	High cargo temperature Poor thermal insulation or air leakage	
	A. Discharge pressure is low.	① Poor compression of compressor	Abrasion of scroll slide section	
		② Hot gas solenoid valve	Not open	
		③ Defrosting solenoid valve	Not open	
		④ Injection solenoid valve	Valve blocked with contamination	
B. Discharge pressure is high	① Evaporator fan	Damages on fan blade		
		Rotation failure of fan motor		
		Actuation of fan motor thermal protector		
V Control is unstable	A. Hunting	① Suction modulating valve	Valve blocked with contamination	
		② Electronic expansion valve	Valve blocked with contamination	
	B. Temperature continues dropping.	① Suction modulating valve	Valve blocked with contamination	
			Magnetic coil malfunction	
			Wire breakage	
	C. Temperature continues rising.	① Suction modulating valve	Valve blocked with contamination	
		② Electronic expansion valve	Valve blocked with contamination	
		③ Evaporator	Insufficient evaporator air flow rate (Refer to III -B-(6).)	
		④ Drier	Drier blocked with contamination	
		⑤ Shortage of refrigerant charging amount	Refrigerant leakage	
	VI Abnormal noise or abnormal vibration.	A. Abnormal noise is generated	① Compressor	Worn-out of bearing
				Abrasion of scroll slide section
Loose-tightened bolt				
② Evaporator fan			Loose fan motor set bolt	
			Deformation of fan motor set leg or loose-tightened bolt	
			Bending of fan motor shaft	
			Worn-out of fan motor bearing	
			Deformation of fan guide	
			Contact between fan and fan guide	
③ Condenser fan			Loose-tightened fan motor set bolt	
			Bending of fan motor shaft	
			Worn-out of fan motor bearing	
		Deformation of fan guide		
		Deformation of condenser front panel		
B. Abnormal vibration generates	① Compressor	Loose-tightened set bolt		
	② Piping	Loose-tightened or missing of clamp bolt		
VII Abnormal frosting on compressor	Frosting area is less than one third of compressor surface.	It is normal, since the unit is controlled to make superheat degree small by electronic expansion valve.		
	Frosting area is more than one third of compressor surface.	Suction gas temperature sensor	Defective contact of sensing section Deviation from specified sensor characteristics	
		Discharge gas temperature sensor	Defective contact of sensing section Deviation from specified sensor characteristics	
		Evaporator inlet sensor	In back-up operation due to faulty sensor	
		Evaporator outlet sensor	In back-up operation due to faulty sensor	
		Electronic Expansion valve	Valve blocked with contamination	
VIII Water-cooled operation is impossible	Although water coupling are connected, condenser fan continues rotating.	① No actuation of water pressure switch	Insufficient cooling water flow rate Water pressure switch malfunction	
		② No trouble with the unit	To prevent temperature in the control box from rising, the condenser fan rotates at CBS of 59°C or higher.	
		③ Refrigerant over charged	Condenser fan is operating due to abnormal high pressure caused by refrigerant over charged	

State	Malfunction occurrence	Abnormal point	Possible cause
IX "Abnormal Ventilator Opening" indicating light	"Abnormal Ventilator Opening" display	Displayed ventilator opening value remains the same even by sliding the ventilator cover.	The ventilator opening detector (VOD) is short-circuited.
			The fixing screws of the VOD's wire or the ventilator cover are loose or come off.
		No ventilator opening value is displayed.	The connector for VOD use is disconnected.

6.2 Alarm codes on electronic controller

If any alarm occurs, search its cause and repair it referring to the following table.

Be sure to check the connectors in the electronic controller as the poor contact of them may cause the controller alarm codes.

Alarm code	Content	Possible cause		
F101	The high-pressure switch (HPS) activates within 30 seconds after the compressor start or the protection devices activates five times at unit start-up.	Discharge pressure regulation valve is defective.		
		Check valve is blocked.		
		Lead wire of the high-pressure switch is broken.		
		High-pressure switch contact is defective.		
		High-pressure switch is defective.		
		Condenser fan motor is in abnormal stop.		
F109	Low pressure lowers abnormally within 2 seconds after compressor started.	Liquid solenoid valve coil is broken.		
		Low-pressure transducer (LPT) value is abnormal.	CPU board is faulty. The low-pressure transducer is faulty.	
F111	High-pressure switch (HPS) does not activate at set value.	High-pressure switch lead wire is broken.		
		High-pressure transducer lead wire is broken.		
F301	Temperature setting request	Set point temperature is not set.		
		Failure of SRAM (on CPU board)		
F401 F403	In the chilled or partial frozen mode, the supply air sensor (SS) and return air sensor (RS) is defective.	Short circuit or breakage of both sensor lead wires		
		Wrong wiring connection on both sensors		
		Both sensors defective		
		CPU board malfunction		
F603	The suction modulating valve does not fully close although it is set to be full-close.	Suction modulating valve coil is broken.		
		Suction modulating valve malfunctions.		
F701	Abnormal power voltage Note) 1.	The voltage is too high.		
		S phase is open.		
		Power supply waveform is not sinusoidal.		
F705	S phase is open phase	The voltage selector is in poor contact.		
		The circuit breaker is in poor contact.		
		Power plug is in poor contact.		
		Power cable is broken		
		Open phase of power supply		
F803	Any following malfunction codes are counted 10 times E101 · E103 · E107 E109 · E203 · E707	Refer to the possible cause of the left mentioned malfunction codes.		
E101	High-pressure switch (HPS) activated during operation.	Refrigerant is overcharged		
		Wrong refrigerant is charged. (i.e. HCFC22)		
		Air entered in the refrigerant system		
		Insufficient air flow rate	Fins are blocked	
			Air passage is blocked by some foreign materials	
			Short circuit of condenser cooling air	
			Wrong installation of condenser fan	
			Condenser fan rotates reverse.	
			Condenser fan breakage.	
		Condenser fan fell out.		
		Ambient temperature is abnormally high		
		Condenser fan motor running is abnormal	Motor stops due to thermal protector actuation.	Blocked finned coil. Air passage is blocked by some foreign materials
			Motor does not run	Wrong wiring
			Water-cooled condenser capacity is decreased	Shortage of cooling-water
		Cooling-water temperature high.		
		Blocked with scale		
HPS malfunction				
Wiring lead breakage				
Poor connection with terminal block board				
Wrong wiring of high pressure switch				
CPU board malfunction				
Power I/O board malfunction				
E103	Electronic overcurrent protection device (electronic OC) actuates.	Compressor lock		
		CPU board malfunction		
		Power I/O board malfunction		
		PT/CT board malfunction		

Note1: If S phase is open, F701 may occur. When F701 and F705 are displayed together, inspect the S phase for opening.

Alarm code	Content	Possible cause			
E103	Compressor thermal protector (CTP) activates.	Shortage of refrigerant amount	Refrigerant leakage		
			Injection solenoid valve is not opened.	Wiring lead breakage	
				Defective wiring	
				Coil burned out	
				Coil fell out	
		Injection capillary is blocked			
	Compressor thermal protector (CTP) malfunction				
	Compressor lock				
E105	Micro-computerized overcurrent protection device (Micro-computerized OC) activates.	Compressor lock			
		Excessive refrigerant supply during defrosting and metering heating	Injection solenoid valve is not closed due to foreign materials caught.		
		The current sensor (CT2) value is abnormal.	CPU board malfunction		
			Current sensor malfunction		
E107	Discharge gas temperature sensor (DCHS) becomes abnormally high during operation.	Injection solenoid valve operates improperly.	Valve is blocked with contamination		
			Wire lead breakage		
			Wrong wiring		
			Coil burned out		
			Coil fell out		
		Injection capillary is blocked			
		High pressure is abnormally high.	Overcharge of refrigerant		
		Compressor burnt			
		Refrigerant shortage			
		Drier is blocked			
		Excessive frost on the evaporator			
		Discharge gas temperature sensor value is abnormal	CPU board malfunction		
			Sensor failure		
Evaporator outlet sensor failure during defrosting					
E109	Low pressure continues to lower abnormally for 2 seconds or longer.	Insufficient refrigerant amount	Shortage of refrigerant amount		
			Refrigerant leakage		
		Liquid solenoid valve is not opened.	Valve blocked with contamination		
			Wiring lead breakage		
			Wrong wiring		
			Coil burned out		
			Coil fell out		
		Electronic expansion valve does not activate.	Valve blocked with moisture		
			Valve blocked with contamination		
			Coil wiring lead breakage or connector disconnection		
			Evaporator inlet or outlet sensor wiring breakage or wrong installation		
			Electronic expansion valve malfunction		
		Drier is blocked			
		Excessive frost on evaporator	Evaporator fan insufficient air circulation	Air passage is blocked by foreign material	
				Evaporator fan breakage	
				Air-short circuit around evaporator	
				Reverse rotation of evaporator fan	
			Fan motor does not run	Evaporator fan fell out	
				Wrong wiring	
				Fan motor thermal protector actuates.	Wiring lead breakage
					Wrong wiring
		Air leaks on the access panel.	Air passage is blocked by foreign materials		
			Ventilator is open.		
Low-pressure transducer value is abnormal	CPU board malfunction				
	Sensor malfunction				
E201	Pump-down does not end within 60 seconds.	Liquid solenoid valve does not close.	Valve blocked with contamination		
			Lead wire breakage		
			Wrong wiring		
			Coil burned out		
			Coil fell out		
			Compressor valve breakage		
		Abrasion of compressor scroll			
		Injection solenoid valve does not close.	Valve blocked with contamination		
			Lead wire breakage		

Alarm code	Content	Possible cause	
E201	Pump-down does not end within 60 seconds.	Injection solenoid valve does not close.	Wrong wiring
			Coil burned out
			Coil fell out
		Leakage of hot gas solenoid valve	Valve blocked with contamination
		Defrosting solenoid valve	Valve blocked with contamination
Discharge gas by-pass solenoid valve	Valve blocked with contamination		
E203	Overcool protection function actuate (control sensor \leq SP- 3.0) in the chilled or partial frozen mode for 3 minutes or longer.	Suction modulating valve does not operate.	Lead wire breakage
			Wrong wiring
			Coil burned out
			Adopter PCB is defective
		Insufficient evaporator fan air flow rate (Only for partial frozen mode)	Air passage is blocked by foreign materials
			Evaporator fan damaged
			Air short circuit around evaporator
		Evaporator fan motor thermal protector activates	Evaporator fan interferes with guide
			Lead wire breakage
			Air passage is blocked by foreign material
E207	Defrosting time is 90 minutes long	Evaporator outlet sensor gets off from the evaporator outlet tube.	
		Insulation pipe cover of evaporator outlet sensor is improperly installed.	
		Evaporator outlet sensor is defective.	
		Defrosting solenoid valve does not open	Lead wire breakage
			Coil burned out
			Valve blocked with contamination
		Hot gas solenoid valve does not open.	Lead wire breakage
			Coil burned out
			Valve blocked with contamination
		Injection solenoid valve does not open	Lead wire breakage
			Wrong wiring
			Coil burned out
			Coil fell out
High-pressure transducer or low-pressure transducer malfunction.			
Evaporator outlet sensor value is abnormal	Printed-circuit board malfunction		
	Sensor malfunction		
Excessive frosting			
E303	Humidity setting request	CPU board (SRAM) malfunction	Resetting
E305	Defrosting interval setting request		
E307	Calendar setting request		
E311	Trip start setting request		
E401	Supply air temperature sensor (SS) malfunction	Line breakage	
		Short circuit	
		Wrong wiring	
		Sensor value is abnormal	Printed-circuit board malfunction
E402	Data recorder supply air temperature sensor (DSS) malfunction	Line breakage	
		Short circuit	
		Wrong wiring	
		Sensor value is abnormal	Printed-circuit board malfunction
E403	Return air temperature sensor (RS) malfunction	Line breakage	
		Short circuit	
		Wrong wiring	
		CPU board malfunction	
E404	Data recorder return air temperature sensor (DRS) malfunction	Line breakage	
		Short circuit	
		Wrong wiring	
		CPU board malfunction	
E405	Discharge temperature sensor (DCHS) malfunction	Line breakage	
		Short circuit	
		Wrong wiring	
		CPU board malfunction	
E406	Suction gas sensor (SGS) malfunction	Line breakage	
		Short circuit	
		Wrong wiring	
		CPU board malfunction	

Alarm code	Content	Possible cause
E407	Evaporator inlet sensor (EIS) malfunction	Line breakage
		Short circuit
		Wrong wiring
		CPU board malfunction
E409	Evaporator outlet sensor (EOS) malfunction	Line breakage
		Short circuit
		Wrong wiring
		CPU board malfunction
E411	Ambient sensor (AMBS) malfunction	Line breakage
		Short circuit
		Wrong wiring
		CPU board malfunction
E413	Low pressure transducer (LPT) malfunction	Line breakage
		Short circuit
		Wrong wiring
		CPU board malfunction
E415	High pressure transducer (HPT) malfunction	Line breakage
		Short circuit
		Wrong wiring
		CPU board malfunction
E417	Voltage sensor (PT1) malfunction	Sensor malfunction
		CPU board malfunction
E419	Voltage sensor (PT2) malfunction	Sensor malfunction
		CPU board malfunction
E421	Current sensor (CT1) malfunction	Sensor malfunction
		CPU board malfunction
E423	Current sensor (CT2) malfunction	Sensor malfunction
		CPU board malfunction
E425 E427 E429	Pulp temperature sensor (USDA1 to 3) malfunction	Wrong wiring in the USDA receptacle.
		Line breakage in the USDA receptacle.
		Short circuit in the USDA receptacle.
		Junction cable breakage
		Junction cable poor contact
		Wrong wiring in the control box
		Short circuit in the control box
		Pulp temperature sensor malfunction
CPU board malfunction		
E431	Humidity sensor (HuS) malfunction	Lead wire breakage
		Wrong wiring
		Humidity sensor malfunction
		CPU board malfunction
E603	Line breakage of suction modulating valve (SMV) or drive circuit malfunction or wrong setting of controller	Lead wire breakage
		Wrong wiring
		CPU board malfunction
		Wrong setting of initial setting of controller (DECOS a, b, c)
E607	Abnormal contact point of manual defrost key (sheet key)	Switch malfunction
		Short circuit
		CPU board malfunction
E707	Momentally power failure	Commercial power supply stops for 40 to 300msec.
E807	Lower ventilator is opened	Lower ventilator is opened during frozen operation

Malfunction and Alarm

when the socket is disconnected or loosened.

Location	Socket No.	Malfunction or Alarm when the socket is disconnected or loosened.
SMV Board (EC6)	CN81 (White)	No Alarm.....No power supply to Controller
	CN82 (Red)	No Alarm.....No power supply to Controller
	CN83 (Yellow)	F803
	CN84 (Blue)	F603
PT/CT Board (EC6)	CN1	F705
	CN2	F705 E315 E417 E421 E423
I/O Board (EC2)	CN26	No Alarm.....No power supply to recorder
CPU Board (CN1)	CN13	No Alarm.....No power supply to Controller
	CN15	No Alarm.....No communication to cpmputer for data down loading
	CN16	No Alarm.....No power supply to MODEM
	CN18	No Alarm.....No "signal" power supply to EV
Terminal Board (TB1)	CN1	E109 → F109 (F803)
	CN2	F101
	CN3	No Alarm.....No power to PCC (No operation)
	CN4	No Alarm.....No power supply to Controller
Terminal Board (TB1)	CN6	F803, E401, E403, E409, E411, E413, E415 ("E" displayed in SS, RS temperature indication for E401, E403)
	CN7	F406 E407 E402 E404 ("E" displayed in DRS, DSS, EIS, SGS temperature indication)

Location	Fuse No.	Malfunction or Alarm when the fuse is broken.
Terminal Board (TB1)	Fu1	F101
	Fu2	BSV
	Fu3	E109 → F109 (F803).....No power to LSV (LSV close)
	Fu4	F603, E315, E417, E421, E423
	Fu5	No Alarm.....No power supply to Controller
	Fu6	No Alarm.....No power supply to Monitoring Cirt

6.3 Troubleshooting for automatic PTI (J-code)

Step	Content	Alarm code	Conclusion	Possible cause	Check method
P00	Basic data record	No indication	No judgment		
P02	Alarm check on all sensor	Same as normal operation	Same as normal operation	Same as normal operation	Same as normal operation
P04	Power supply check	No indication	Same as normal operation	Same as normal operation	Same as normal operation
P05	Compressor start running Check	J051	Same as normal operation	Same as normal operation	Same as normal operation
P06	HPS check	J061	Abnormal OFF point	(1) HPS malfunction (2) High pressure transducer (HPT) malfunction (3) Gas leak from Gauge manifold (No unit malfunction)	(1) Check HPS (2) Compare to Gauge manifold (3) Remove Gauge manifold.
		J062	Not return		
		J064	High pressure does not rise.		
		J065	High pressure does not drop.		
P08	Pump down check	J081	Pump down requires too long time.	Blocked with contamination of liquid solenoid valve	Try again S-PTI
				Leakage of hot gas by-pass solenoid valve	Touch the outlet pipe of the solenoid valve.
				Leakage of defrosting solenoid valve	Touch the outlet pipe of the solenoid valve.
				Leakage of discharge gas by-pass solenoid valve	Touch the outlet pipe of the solenoid valve.
P10	Solenoid valve check	J101	Excessive leakage of solenoid valve	Liquid solenoid valve malfunction	Check Liquid solenoid valve
				Suction modulating valve malfunction	Check Suction modulating valve
				Injection valve malfunction	Check Injection valve
P12	RS, SS accuracy check	J121	Excessively large temperature difference between RS and DRS Excessively large temperature difference between SS and DSS	SS malfunction	Compare the SS with the DSS on the controller panel.
				RS malfunction	Compare the RS with the DS on the controller panel.
P14	HPT, LPT accuracy check	J141	Excessively large pressure difference between HPT and LPT	HPT malfunction	Compare the high pressure valve with the gauge manifold of HPT (on the controller panel).
				LPT malfunction	Compare the low pressure valve with the gauge manifold of LPT (on the controller panel)
P16	Evaporator fan Hi/Lo speed operation check	J161	Abnormal operation of evaporator fan speed	Evaporator fan and motor malfunction. Magnetic contactor (EFH/L) and wiring malfunction.	Check Evaporator fan and motor. Check magnetic contactor (EFH/L) and wiring.
P20	Check on economizer solenoid valve (ESV)	J201	ESV does not open.	ESV coil malfunction	Check on ESV coil, wiring and terminals.
				ESV malfunction	Check on capillary tube temperature on ESV outlet.

Step	Content	Alarm code	Conclusion	Possible cause	Check method
P22	Check on discharge gas by-pass solenoid valve (BSV)	J221	BSV does not open.	BSV coil malfunction	Check on BSV coil, wiring and terminals.
				BSV malfunction	Check on outlet piping temperature of BSV
P24	Check on defrosting solenoid valve (DSV)	J241	DSV does not open.	DSV coil failure	Check on DSV coil, wiring and terminals.
				DSV malfunction	Check on outlet piping temperature of DSV
P26	Standard Pull down operation	No indication			
P28	SMV function check (Open SMV to 3%)	J281	(LPT : decrease 20Kpa)	SMV coil failure SMV malfunction	Refer 4.2.5. Check appearance (Replace coil bracket)
P29	Electronic expansion valve check	J291	Pump down time is too long.	Electronic expansion valve wiring malfunction	Check knocking sound of the coil Disconnect and connect the connector of the coil
				Electronic expansion valve coil burn out.	Check on knocking sound of coil.
				Leakage of hot gas by-pass solenoid valve	Touch the outlet pipe of the solenoid valve.
				Leakage of defrosting solenoid valve	Touch the outlet pipe of the solenoid valve.
				Leakage of discharge gas by-pass solenoid valve	Touch the outlet pipe of the solenoid valve.
P30	ISV opening or closing check	J301	ISV does not open.	ISV coil malfunction	Check on ISV coil, wiring and terminals.
				ISV malfunction	Check on capillary tube temperature on ISV outlet.
P32	HSV opening or closing check	J321	HSV does not open.	HSV coil malfunction	Check on HSV coil, wiring and terminals.
				HSV malfunction	Check on outlet piping temperature of HSV
P50	Pull-down cooling capacity	J501	Out of ambient temperature condition	No unit malfunction Ambient temperature is lower than -10°C Ambient temperature is higher than 43°C	Check ambient temperature.
		J502	Pull down time is too long.	Same as normal operation	Same as normal operation
P60	0°C control	No indication	No judgement		
P70	Defrosting operation check	J701	Out of starting condition. (EOS is 20°C or more.)	Wrong installation of EOS.	Check the installation of EOS.
				Leakage of hot gas solenoid valve	Touch the outlet pipe of the solenoid valve.
		J702	Defrost time is too long.	Wrong installation of EOS. EOS malfunction.	Check the installation of EOS. Check EOS.
P80	Pull-down cooling capacity	J801	Pull down time is too long.	Same as normal operation	Same as normal operation
P90	-18°C control	No indication	No judgement		

Note : "Same as normal operation" means that it is same as judgement, countermeasure and check method at normal operation.

6.4 Emergency operation

6.4.1 Emergency operation of controller

In case of the controller malfunction, emergency operation can be executed by using emergency operation kit.

(1) Components to be prepared (emergency operation kit)

- Short circuit connector --- Stored on the back of CPU/IO board case in the control box.
- Electronic expansion valve emergency cap --- Stored in the spare parts kit.
- Suction modulating valve emergency magnet --- Stored in the spare parts kit.

(2) On-site work

The on-site work is requested as follows for Emergency Operation

- ① Wiring change for short circuit operation
 - '1) Wiring change for cutting off the power to CPU board
 - '2) Wiring change for making the forced running of Compressor, Condenser Fan and Evaporator Fans.
 - * Connect the short circuit connector stored on the back of controller.
 - * For the details, refer to the section 6.4.2 "Short Circuit Operation"
- ② Electronic Expansion Valve opening adjustment for 1/4 opening.
 - * Use Emergency Cap for the for 1/4 opening.
 - * For the details, refer to the section 6.4.3 "Opening Adjustment"
- ③ Suction Modulation Valve opening adjustment for full opening.
 - * Use Emergency Magnet for full the opening.
 - * For the details, refer to the section 6.4.4 "Emergency operation of suction modulating valve"

(3) Operating condition at emergency

Temperature can not be controlled. Turn the circuit breaker on or off to maintain the target temperature.

Mode	Available function of protection devices	Operating condition of unit
Cooling operation	RPP : Reverse phase protection device HPS : High pressure switch CTP : Compressor thermal protector	<ul style="list-style-type: none"> ○ Compressor runs continuously. ○ Evaporator fan runs at low speed continuously. ○ Condenser fan runs continuously. ○ Electronic expansion valve operates with fixed opening by the emergency cap. ○ Suction modulating valve operates with full opening by emergency magnet.
Heat operation	—————	<ul style="list-style-type: none"> ○ Compressor stops. ○ Evaporator fan runs at high speed continuously. ○ Condenser fan stops.

6.4.2 Short circuit operation of controller

For cutting off the power to CPU board

① Turn the circuit breaker OFF.

For making the forced running of CFM and EFM.

③ Remove Short Circuit Connector SCC1-1(Blue), SCC1-2(Red) and SCC2(Blue) stored on back of controller.

④ Connect the Short Circuit Connector SCC1-2(Red) to CN8 and SCC2(Blue) to CN10 on terminal board.

For checking reverse phase power

⑤ Turn the circuit breaker ON. If the power is in reverse phase, EFM runs reversely with high speed. Then fresh air is sucked to Outlet Hole and discharged from Inlet Hole at the lower ventilator.

For correction of reverse phase power

⑥ If it is in reverse phase, turn the circuit breaker OFF and replace the reverse phase correction socket to opposite side. ("Lower socket CN-C1 to Upper CN-C2" or "Upper CN-C2 to Lower CN-C1")

Operate continuously for heating operation.

For cooling operation, go to next step ⑦.

For cooling operation

⑦ Connect Short Circuit Connector SCC1-1(Blue) to CN8 and SCC2(Blue) to CN9 on terminal board.

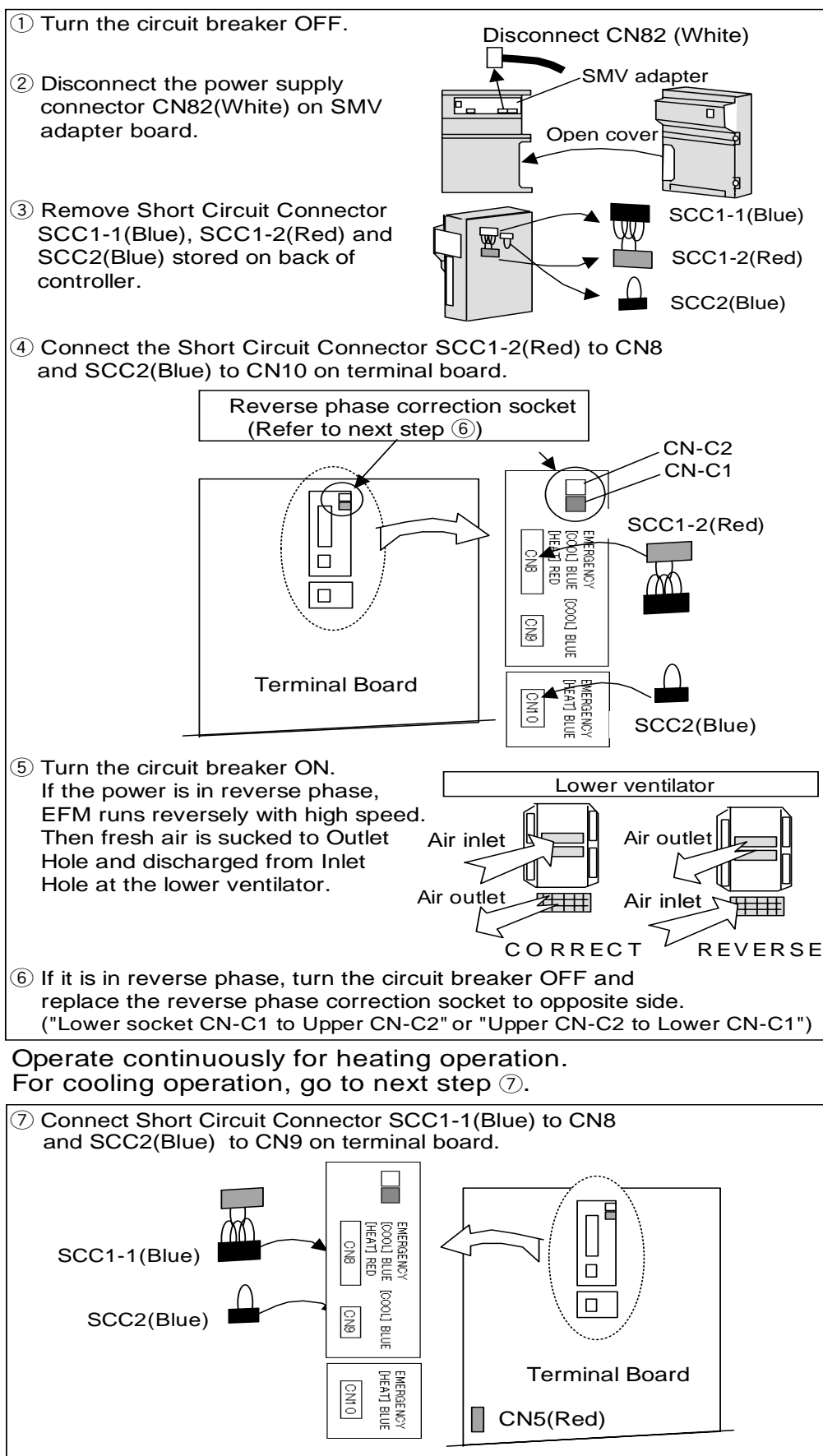

6.4.3 Opening adjustment of electronic expansion valve

In case of the controller malfunction or faulty electronic expansion valve coil, electronic expansion valve can be operated with fixed valve opening by using emergency cap.

Caution

If the electronic expansion valve is energized while the coil is removed from valve body, the coil driver with which the valve needle is pushed protrude excessively. In this state, when the valve is restored from emergency operation, the needle may be caught with the driver resulting the valve fully closed.

Therefore, be sure not to energize the coil before emergency operation.

[Disenergizing of coil]

- When controller malfunction
Disconnect the red power supply connector (red : CN5) on the terminal board when removing of controller short circuit connector (SCC1-1 or SCC1-2) to disenergize the electronic expansion valve.(described in the section 6.4.2)
- When only electronic expansion valve is conducted emergency operation.
Disconnect CN18 on the controller CPU board to disenergize the electronic expansion valve.

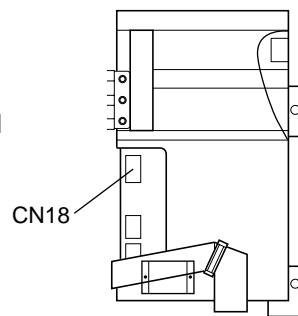

- ① Remove the coil.
- ② Set the emergency cap on the electronic expansion valve body.
- ③ Fully close the electronic expansion valve by turning the minus recessed screw of emergency cap clockwise with miniature driver.
(Tightening torque: approx. 1 kgf · cm The torque is required to tighten the valve softly until the driver stops turning)
- ④ Then slightly open the electronic expansion valve by turning the minus recessed screw of emergency cap counter clockwise for 60°
- ⑤ Apply a loose-free adhesive on the screw.

- ① Remove the coil. ② Set the emergency coil cap. ③ Fully close. ④ Slightly open.

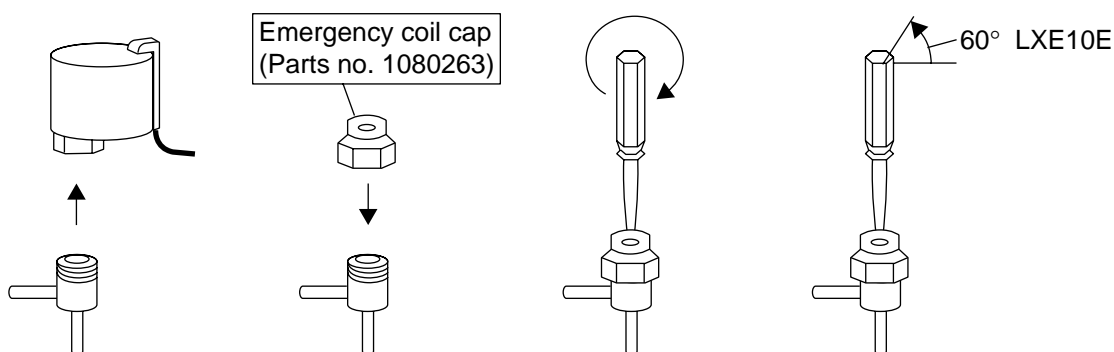

Recommendation

*EV opening adjustment during pull-down operation

To shorten the operation hours, it is recommended that the opening be adjusted up to max. 50%. However if the frost is observed around the comp. body or the super heat is insufficient due to wet operation, close slightly the opening.

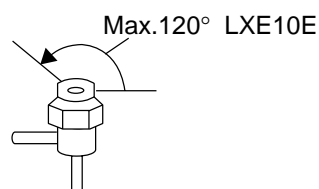

6.4.4 Emergency operation of suction modulation valve:

In case of emergency, there are two ways to open the suction modulating valve manually. It is important to follow these steps in this sequence. Use step 1 first. If this is not working, then use step 2.

Step 1. Fully open the valve by using the dip switch on the adopter PCB.

In case of controller malfunction while the suction modulating valve and adopter PCB are normal, turn the No. 1 dip switch ON to open the valve automatically. At the same time the dip switch is switched, a clicking sound can be heard that the valve fully opens. If nothing will be heard, continue to step 2.

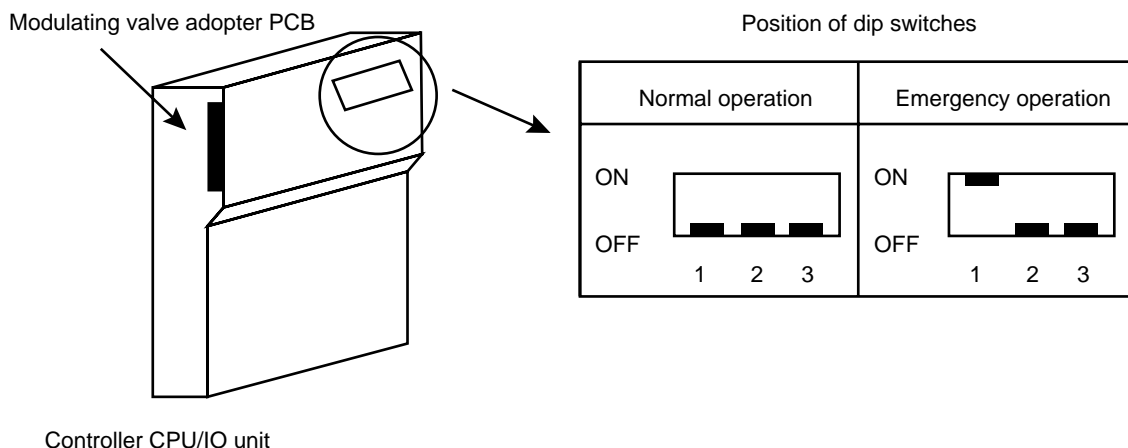

Step 2. Fully open the valve by using an emergency magnet.

If the method of step 1 was not working, use this step to open the valve.

In case of the suction modulating valve or adopter PCB malfunction, the valve can be opened by using an emergency magnet.

- ① Prepare Emergency Magnet
- ② Remove the coil of the modulating valve.
- ③ Contact the emergency magnet to the coil mounting section of the valve with the "UPSIDE" up. (the emergency magnet is attracted to the coil installing section by magnetic force of the inside driving magnet)
- ④ Rotate the emergency magnet counter clockwise to open the valve fully. (when the valve is fully opened, the inside driving magnet will be inactive and the emergency magnet can be removed)

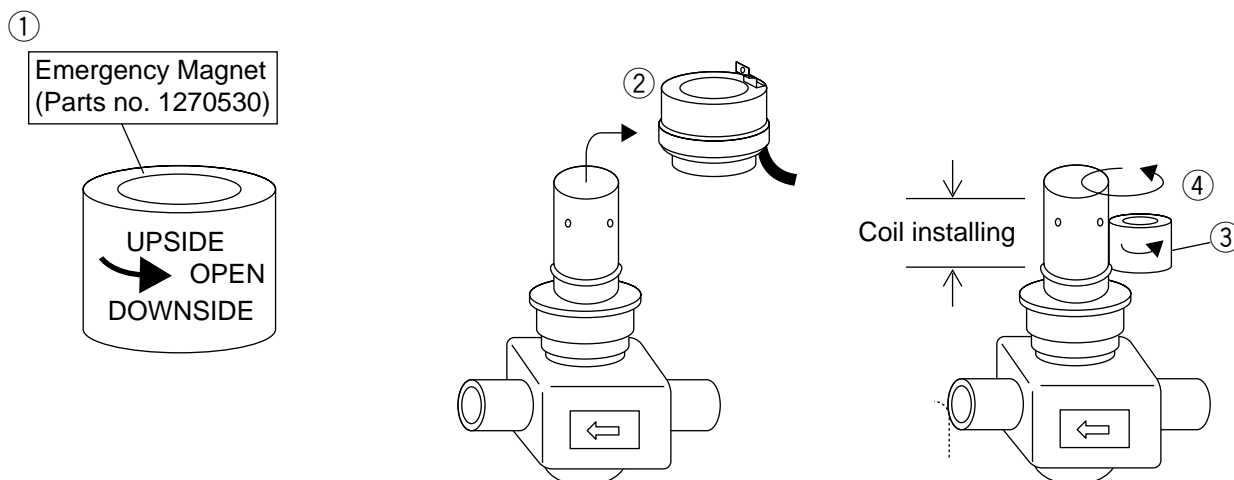

6.4.5 Automatic Back up for supply / return air temperature sensors

When the unit is equipped with the data recorder sensors, the following emergency operations are available.

When the DRS and DSS are used for the emergency operation, DATA RECORDER SENSOR ON/OFF SETTING to be set OFF. (Refer to page 3-27, basic function setting mode.)

RS: Return air temperature sensor DRS: Data recorder return air temperature sensor

SS: Supply air temperature sensor DSS: Data recorder supply air temperature sensor

Malfunction code	Abnormal point	Unit back-up operation
E401	SS Supply air temperature sensor (SS) for control malfunction	Chilled mode: Back-up operation with DSS Frozen mode: only malfunction code indication
E402	DSS Data recorder supply air temperature sensor (DSS) malfunction	Only malfunction code indication
E401 E402	Both SS and DSS malfunction	Chilled mode: Back-up operation with RS -2°C . Frozen mode: only malfunction code indication
E403	RS Return air temperature sensor (RS) for control malfunction	Chilled mode: only malfunction code indication Frozen mode: Back-up operation with DRS
E404	DRS Data recorder supply air temperature sensor (DRS) malfunction	Only malfunction code indication
E403 E404	Both RS and DRS malfunction	Chilled mode: only malfunction code indication Frozen mode: Back-up operation with SS $+5^{\circ}\text{C}$
H006	Chilled mode: Temperature difference is 2°C or more between SS and DSS or more than one hour.	Only malfunction code indication
	Frozen mode: Temperature difference is 2°C or more between RS and DRS or more than one hour.	Only malfunction code indication

7. APPENDIX

7.1 Standard tightening torques for bolts

	Bolt size	Main part	Tightening torque		
			N · m	kgf · cm	lbf · ft
Stainless steel	M4	Small parts	1.6	16	1.2
	M5	Solenoid valve	3.0	31	2.2
	M6	Access panel	5.2	53	3.8
	M8	Evaporator fan motor Condenser fan motor Control box Service door	12.3	125	9.1
	M10	Evaporator fan motor mounting base Compressor suction flange Compressor discharge flange	25.2	257	18.6
	M12	Compressor	42.7	435	31.5

Note: Tolerance of tightening torque is within $\pm 10\%$.

7.2 Standard tightening torque for flare nut

Pipe size		Main part	Tighten torque		
mm	in.		N · m	kgf · cm	lbf · ft
$\phi 6.4$	2/8	Compressor pressure port	15.7	160	11.3
$\phi 9.5$	3/8	–	36.3	370	26.8
$\phi 12.7$	4/8	Except Dryer	54.9	500	40.5
$\phi 12.7$	4/8	Only Dryer	28.0	286	20.7

Note: Tolerance of tightening torque is within $\pm 10\%$.

7.3 Standard tightening torque for stop valve

	Discharge side stop valve			Suction side stop valve		
	N · m	kg · cm	lbf · ft	N · m	kg · cm	lbf · ft
Backseat torque	20	204	14.8	35	357	25.8
Grand torque	15	153	11.8	15	153	11.8

Note: Tolerance of tightening torque is within $\pm 10\%$.

7.4 Resistance of motor coil and solenoid valve coil

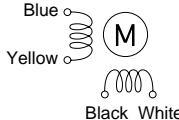
Symbol	Parts name	Value of resistance Ω	Remarks
CM	Compressor motor coil	1.780 Ω (@75°C)	
CFM	Condenser fan motor coil	57.2 Ω	
EFM	Evaporator fan motor coil	19.4 Ω	
LSV	Liquid solenoid valve coil	15.2 \pm 1.1 Ω (common)	
HSV	Hot gas solenoid valve coil		
DSV	Defrosting solenoid valve coil		
ISV	Injection solenoid valve coil		
ESV	Economizer solenoid valve coil		
BSV	Hot gas by-pass solenoid valve coil		
RSV	Reheat coil solenoid valve coil		
CSV	Capillary solenoid valve coil		
EV	Electronic expansion valve coil		
SMV	Suction modulation valve coil	Blue - Yellow : 113 Ω Black - White : 113 Ω	

※The values of resistance are at room temperature excluding those of compressor.

7.5 Standard tightening torque for electronic expansion valve coil (EV coil)

N · m	kgf · cm	lbf · ft
13.7 to 15.7	134 to 164	10.1 to 11.6

7.6 HFC134a, temperature - vapor pressure characteristics table

Temperature		Vapor pressure		Temperature		Vapor pressure	
°C	kPa	kg/cm ² · G		°C	kPa	kg/cm ² · G	
-40.0	-49	-0.5015		20.0	470	4.7977	
-39.0	-46	-0.4734		21.0	488	4.9795	
-38.0	-44	-0.4440		22.0	507	5.1656	
-37.0	-41	-0.4135		23.0	525	5.3560	
-36.0	-37	-0.3817		24.0	544	5.5508	
-35.0	-34	-0.3486		25.0	564	5.7500	
-34.0	-31	-0.3141		26.0	584	5.9538	
-33.0	-27	-0.2783		27.0	604	6.1621	
-32.0	-24	-0.2410		28.0	625	6.3751	
-31.0	-20	-0.2023		29.0	647	6.5929	
-30.0	-16	-0.1621		30.0	668	6.8154	
-29.0	-12	-0.1204		31.0	691	7.0428	
-28.0	-8	-0.0771		32.0	713	7.2751	
-27.0	-3	-0.0322		33.0	737	7.5124	
-26.0	1	0.0144		34.0	760	7.7548	
-25.0	6	0.0627		35.0	785	8.0023	
-24.0	11	0.1128		36.0	810	8.2551	
-23.0	16	0.1646		37.0	835	8.5131	
-22.0	21	0.2183		38.0	861	8.7765	
-21.0	27	0.2739		39.0	887	9.0453	
-20.0	32	0.3314		40.0	914	9.3196	
-19.0	38	0.3908		41.0	941	9.5994	
-18.0	44	0.4523		42.0	969	9.8849	
-17.0	51	0.5159		43.0	998	10.1762	
-16.0	57	0.5816		44.0	1027	10.4732	
-15.0	64	0.6494		45.0	1057	10.7761	
-14.0	71	0.7195		46.0	1087	11.0850	
-13.0	78	0.7918		47.0	1118	11.3999	
-12.0	85	0.8664		48.0	1149	11.7209	
-11.0	93	0.9434		49.0	1182	12.0481	
-10.0	100	1.0229		50.0	1214	12.3815	
-9.0	108	1.1048		51.0	1248	12.7213	
-8.0	117	1.1892		52.0	1281	13.0676	
-7.0	125	1.2761		53.0	1316	13.4203	
-6.0	134	1.3657		54.0	1351	13.7797	
-5.0	143	1.4580		55.0	1387	14.1457	
-4.0	152	1.5530		56.0	1424	14.5185	
-3.0	162	1.6508		57.0	1461	14.8982	
-2.0	172	1.7514		58.0	1499	15.2848	
-1.0	182	1.8549		59.0	1538	15.6785	
0.0	192	1.9613		60.0	1577	16.0793	
1.0	203	2.0708		61.0	1617	16.4873	
2.0	214	2.1833		62.0	1658	16.9027	
3.0	225	2.2989		63.0	1699	17.3254	
4.0	237	2.4177		64.0	1741	17.7557	
5.0	249	2.5398		65.0	1784	18.1936	
6.0	261	2.6651		66.0	1828	18.6391	
7.0	274	2.7937		67.0	1872	19.0925	
8.0	287	2.9258		68.0	1918	19.5539	
9.0	300	3.0613		69.0	1964	20.0232	
10.0	314	3.2004		70.0	2010	20.5007	
11.0	328	3.3430		71.0	2058	20.9864	
12.0	342	3.4892		72.0	2107	21.4805	
13.0	357	3.6392		73.0	2156	21.9831	
14.0	372	3.7929		74.0	2206	22.4943	
15.0	387	3.9505		75.0	2257	23.0142	
16.0	403	4.1119		76.0	2309	23.5430	
17.0	419	4.2773		77.0	2362	24.0807	
18.0	436	4.4467		78.0	2415	24.6276	
19.0	453	4.6201		79.0	2470	25.1837	
				80.0	2525	25.7492	

Conversion rate : 1kg · f/cm² · G=98.0665kPa

**7.7 Temperature sensor characteristics table
(SS/RS/DSS/DRS/RSS/RRS/EIS/EOS/SGS/AMBS)**

Temperature(°C)	Temperature(°F)	Resistance(kΩ)	Temperature(°C)	Temperature(°F)	Resistance(kΩ)
+ 50	+ 122	0.985	+ 0	+ 32	6.860
+ 49	+ 120.2	1.018	- 1	+ 30.2	7.176
+ 48	+ 118.4	1.054	- 2	+ 28.4	7.508
+ 47	+ 116.6	1.090	- 3	+ 26.6	7.857
+ 46	+ 114.8	1.128	- 4	+ 24.8	8.226
+ 45	+ 113	1.167	- 5	+ 23	8.614
+ 44	+ 111.2	1.208	- 6	+ 21.2	9.023
+ 43	+ 109.4	1.251	- 7	+ 19.4	9.454
+ 42	+ 107.6	1.296	- 8	+ 17.6	9.909
+ 41	+ 105.8	1.342	- 9	+ 15.8	10.39
+ 40	+ 104	1.390	- 10	+ 14	10.89
+ 39	+ 102.2	1.441	- 11	+ 12.2	11.43
+ 38	+ 100.4	1.493	- 12	+ 10.4	11.99
+ 37	+ 98.6	1.548	- 13	+ 8.6	12.59
+ 36	+ 97	1.605	- 14	+ 6.8	13.22
+ 35	+ 95	1.665	- 15	+ 5	13.88
+ 34	+ 93.2	1.727	- 16	+ 3.2	14.59
+ 33	+ 91.4	1.791	- 17	+ 1.4	15.33
+ 32	+ 89.6	1.859	- 18	- 0.4	16.12
+ 31	+ 87.8	1.929	- 19	- 2.2	16.95
+ 30	+ 86	2.003	- 20	- 4	17.83
+ 29	+ 84.2	2.080	- 21	- 5.8	18.76
+ 28	+ 82.4	2.160	- 22	- 7.6	19.75
+ 27	+ 80.6	2.244	- 23	- 9.4	20.80
+ 26	+ 78.8	2.331	- 24	- 11.2	21.91
+ 25	+ 77	2.423	- 25	- 13	23.08
+ 24	+ 75.2	2.519	- 26	- 14.8	24.33
+ 23	+ 73.4	2.619	- 27	- 16.6	25.66
+ 22	+ 71.6	2.724	- 28	- 18.4	27.06
+ 21	+ 69.8	2.833	- 29	- 20.2	28.56
+ 20	+ 68	2.948	- 30	- 22	30.15
+ 19	+ 66.2	3.068	- 31	- 23.8	31.83
+ 18	+ 64.4	3.193	- 32	- 25.6	33.63
+ 17	+ 62.6	3.325	- 33	- 27.4	35.53
+ 16	+ 60.8	3.463	- 34	- 29.2	37.56
+ 15	+ 59	3.607	- 35	- 31.0	39.72
+ 14	+ 57.2	3.758	- 36	- 32.8	42.02
+ 13	+ 55.4	3.917	- 37	- 34.6	44.46
+ 12	+ 53.6	4.083	- 38	- 36.4	47.07
+ 11	+ 51.8	4.258	- 39	- 38.2	49.85
+ 10	+ 50	4.441	- 40	- 40	52.81
+ 9	+ 48.2	4.633			
+ 8	+ 46.4	4.834			
+ 7	+ 44.6	5.046			
+ 6	+ 42.8	5.268			
+ 5	+ 41	5.501			
+ 4	+ 39.2	5.747			
+ 3	+ 37.4	6.004			
+ 2	+ 35.6	6.275			
+ 1	+ 33.8	6.560			

7.8 Temperature sensor characteristics table (DCHS)

Temperature(°C)	Temperature(°F)	Resistance(kΩ)	Temperature(°C)	Temperature(°F)	Resistance(kΩ)
72	162	32.783	102	216	12.566
74	165	30.629	104	219	11.835
76	169	28.635	106	223	11.153
78	172	26.787	108	226	10.515
80	176	25.073	110	230	9.919
82	180	23.482	112	234	9.361
84	183	22.005	114	237	8.840
86	187	20.633	116	241	8.351
88	190	19.358	118	244	7.894
90	194	18.171	120	248	7.465
92	198	17.066	122	252	7.063
94	201	16.037	124	255	6.685
96	205	15.078	126	258	6.331
98	208	14.184	128	262	5.998
100	212	13.350	130	266	5.686

7.9 High pressure transducer characteristics table

Pressure (kPa · G)	Out put (V)	Pressure (kPa · G)	Out put (V)
0	0.50	1100	1.62
100	0.60	1200	1.72
200	0.70	1300	1.83
300	0.81	1400	1.93
400	0.91	1500	2.03
500	1.01	1600	2.13
600	1.11	1700	2.23
700	1.21	1800	2.34
800	1.32	1900	2.44
900	1.42	2000	2.54
1000	1.52	2100	2.64

7.10 Low pressure transducer characteristics table

Pressure (kPa · G)	Out put (V)
- 500	- 1.03
- 400	- 0.72
- 300	- 0.42
- 200	- 0.11
- 100	0.19
0	0.50
100	0.81
200	1.11
300	1.42
400	1.72
500	2.03
600	2.34
700	2.64
800	2.95
900	3.25
1000	3.56

7.11 Piping diagram

●LXE10E

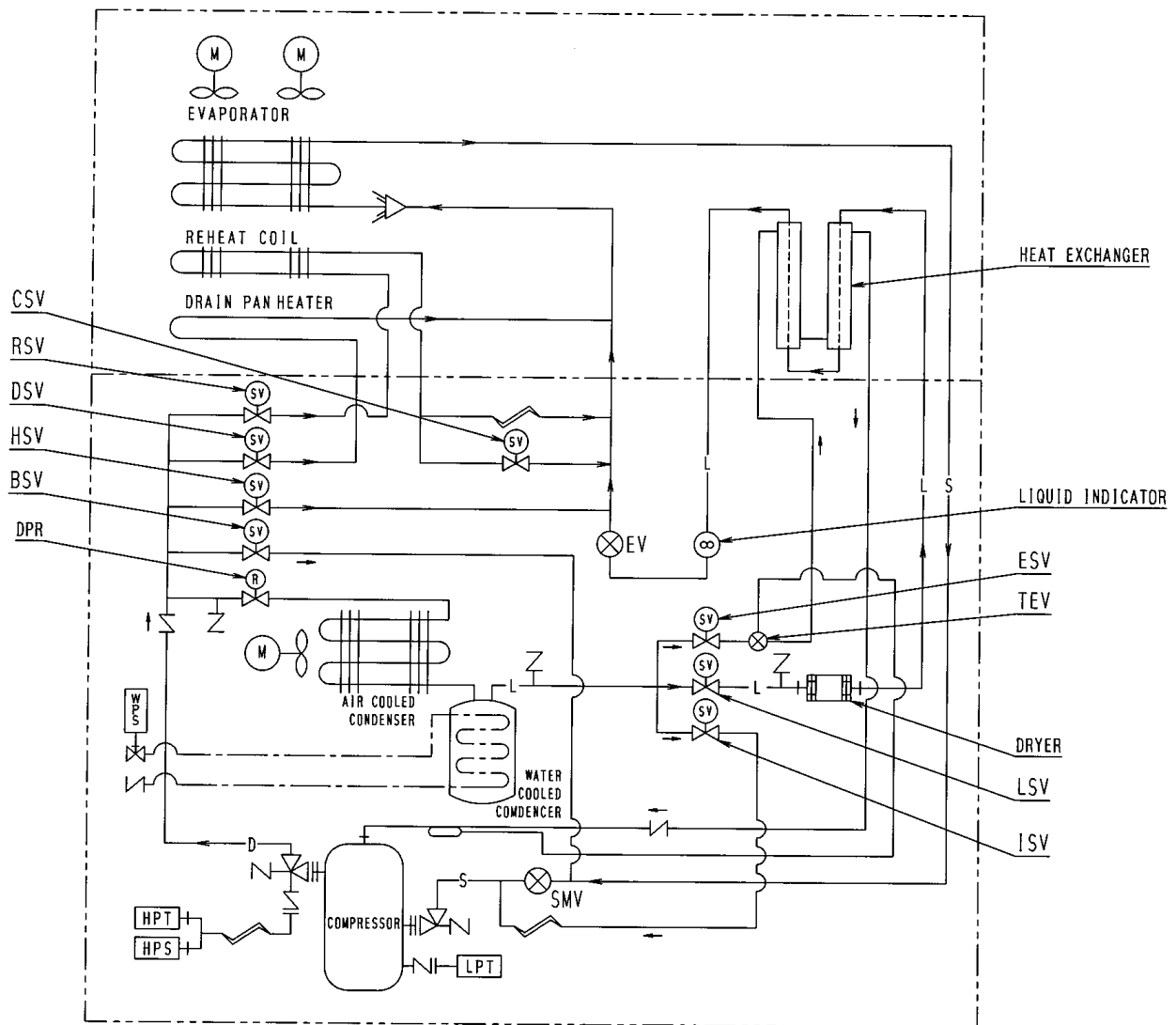

- | | | |
|-------------------------------|---|----------------------------------|
| EV:Electronic Expansion Valve | SMV:Suction Modulation Valve | DPR:Discharge pressure regulator |
| LSV:Liquid Solenoid Valve | HSV:Hot Gas Solenoid Valve | |
| DSV:Defrost Solenoid Valve | ISV:Injection Solenoid Valve | |
| ESV:Economizer Solenoid Valve | BSV:Discharge Gas Bypass Solenoid Valve | |
| WPS:Water pressure switch | CSV:Capillary Solenoid Valve | |

7.12 Pilot lamps

Four pilot lamps which indicate operating mode are mounted on the controller in the control box.

Pilot lamp	Color	Operating condition
COMP.	Green	The compressor is running
DEFROST	Red	The unit is under defrosting operation
IN RANGE	Orange	The inside temperature is within the proper range (within $\pm 2.0^{\circ}\text{C}$ ($\pm 3.6^{\circ}\text{F}$) of the preset temperature).
DE-HUMID.	Red	The unit is set to the dehumidification control operation. (optional)

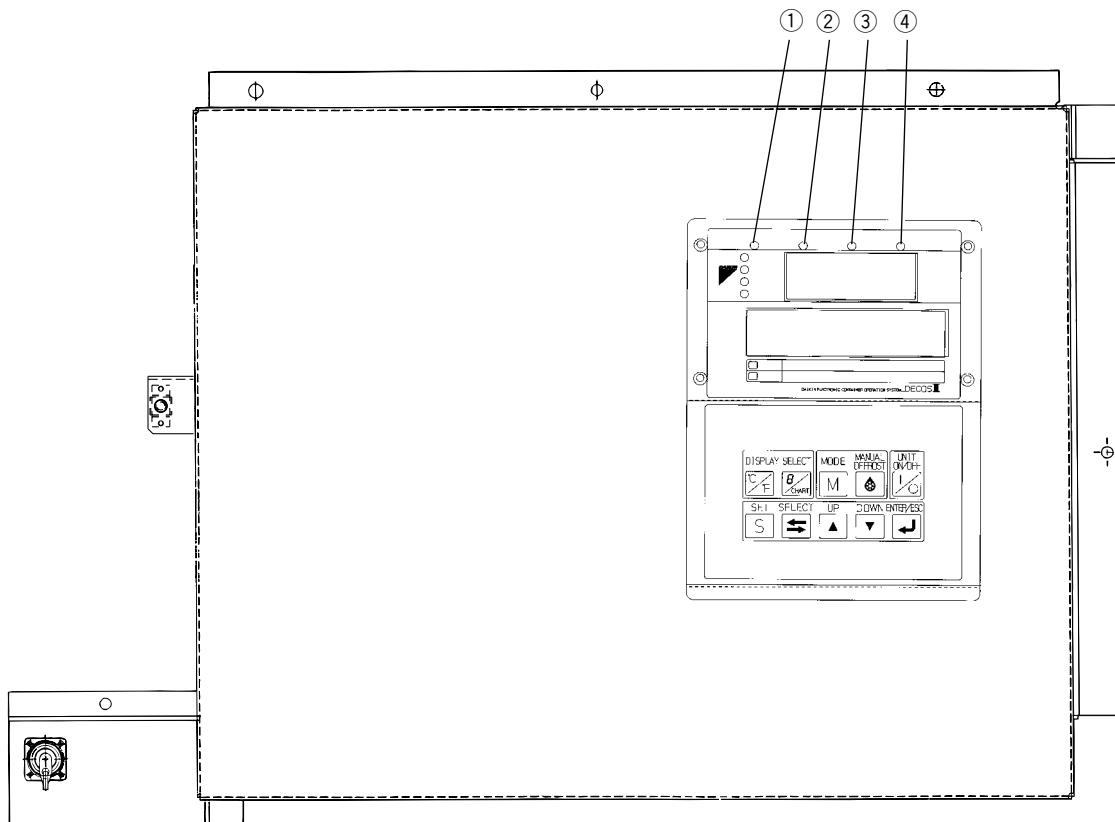

- ① COMP. (green)
- ② DEFROST (red)
- ③ IN RANGE (orange)
- ④ DE-HUMID. (yellow)

7.13 Fuse protection table

	Protection of:	Wiring diagram:
Fuse 1 (250V, 10A)	<ul style="list-style-type: none">• High pressure switch (HPS)• Compressor contactor (CC)• Evaporator fan contactor high speed (EFH)• Evaporator fan contactor low speed (EFL)• Condensor fan contactor (CFC)• Compressor terminal protector (CTP)• Phase correction contactor (PCC1, PCC2)	Drawing 7.14 at TB1 print board page 7-10
Fuse 2 (250V, 10A)	<ul style="list-style-type: none">• Gas bypass solenoid valve (BSV)• Defrost solenoid valve (DSV)	Drawing 7.14 at TB1 print board page 7-10
Fuse 3 (250V, 10A)	<ul style="list-style-type: none">• Hot gas solenoid valve (HSV)• Liquid solenoid valve (LSV)• Injection solenoid valve (ISV)• Economizer solenoid valve (ESV)	Drawing 7.14 at TB1 print board page 7-10
Fuse 4 (250V, 10A)	<ul style="list-style-type: none">• Electronic expansion valve (EV)• PT and CT board	Drawing 7.14 at TB1 print board page 7-10
Fuse 5 (250V, 10A)	<ul style="list-style-type: none">• Recorder• LED indication• LCD display	Drawing 7.14 at TB1 print board page 7-10
Fuse 6 (250V, 10A)	<ul style="list-style-type: none">• Remote monitoring receptacle (RM)	Drawing 7.14 at TB1 print board page 7-10
Fuse 7 (250V, 5A)	<ul style="list-style-type: none">• Suction modulating valve (SMV)	Drawing 7.14 at EC6 print board page 7-10

<https://daikin-p.ru>

7.15 Stereoscopic wiring diagram

●LXE10E-1

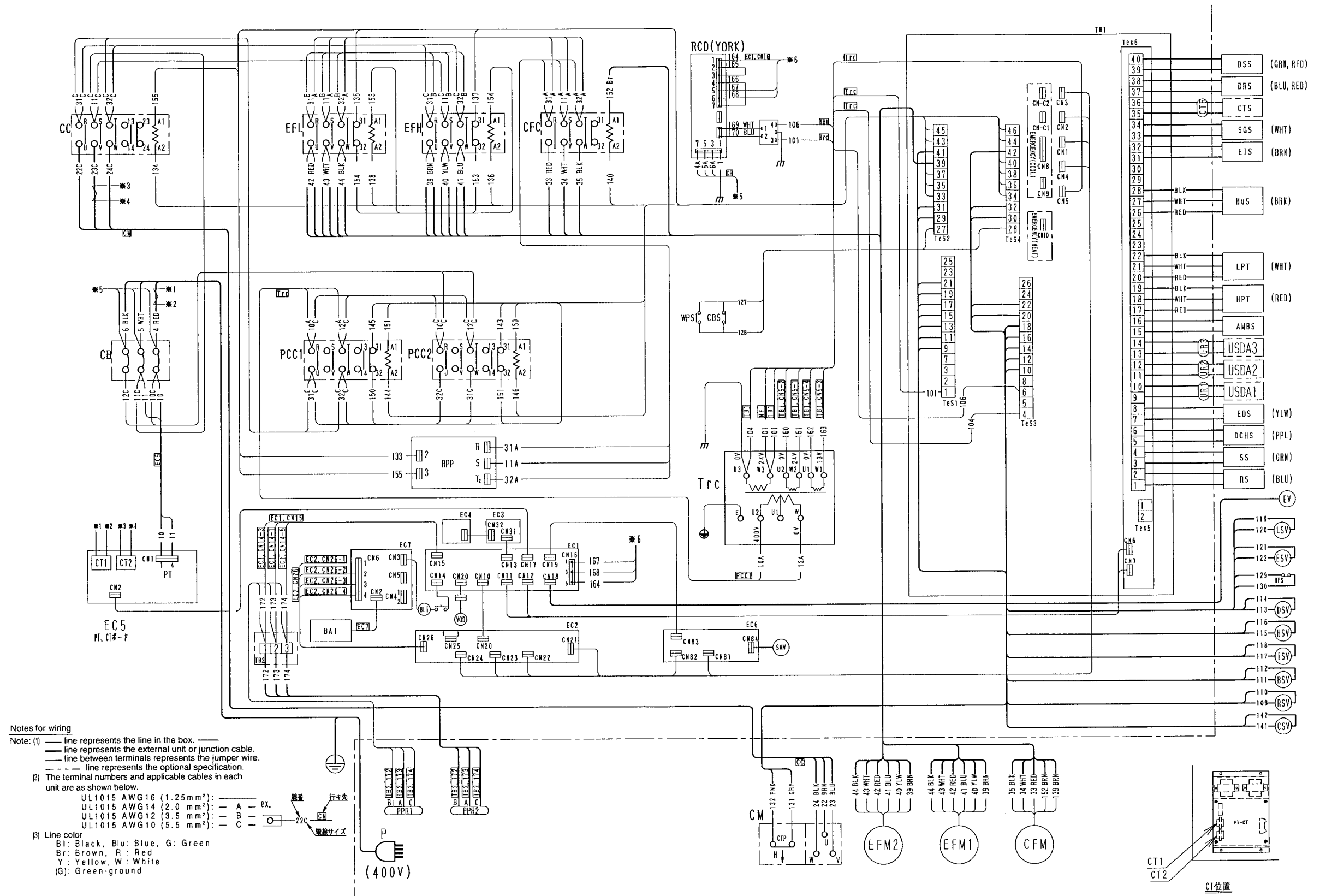

<https://daikin-p.ru>

DAIKIN INDUSTRIES, LTD.

Head Office. Umeda Center Bldg., 4-12, Nakazakinishi 2-chome, Kita-ku, Osaka, 530-8323 Japan.

Tel: 06-6373-4338 (From overseas 81-6-6373-4338)

Fax: 06-6373-7297 (From overseas 81-6-6373-7297)

Tokyo Office. Tokyo Opera City Tower 12F. 3-20-2 Nishi-Shinjuku, Shinjuku-ku, Tokyo 163-1412, Japan.

Tel: 03-5353-7860 (From overseas 81-3-5353-7860)

Fax: 03-5353-7913 (From overseas 81-3-5353-7913)