

<https://daikin-p.ru>

DAIKIN



Marine type Container Refrigeration Unit

船用集装箱制冷机组

Service Manual · Parts List

维修操作手册 · 零部件表

Optional Functions · 选购件功能编

LXE10E-A15F

LXE10E-A15G

LXE10E-A15H

DAIKIN INDUSTRIES, LTD.

大金工业株式会社

TR06-12A

Covered Models

Regarding the features, operation and after servicing, please refer to the service manual(TR02-14).

记载机型

关于本装置的特点，使用以及售后服务等内容，请参阅维护说明书 TR03-01。

<https://daikin-p.ru>

CONTENTS

1. Names of components	4
2. Transducer	5
3. Initial setting table into spare controller	6
4. Refrigerant piping diagram	7
5. Schematic wiring diagram	8
6. Stereoscopic wiring diagram	9

目 次

1. 部件名称	11
2. 传感器	12
3. 备用控制器的初始设定表	13
4. 系统管路图	14
5. 配线示意图	15
6. 配线立体图	16

1. Names of components

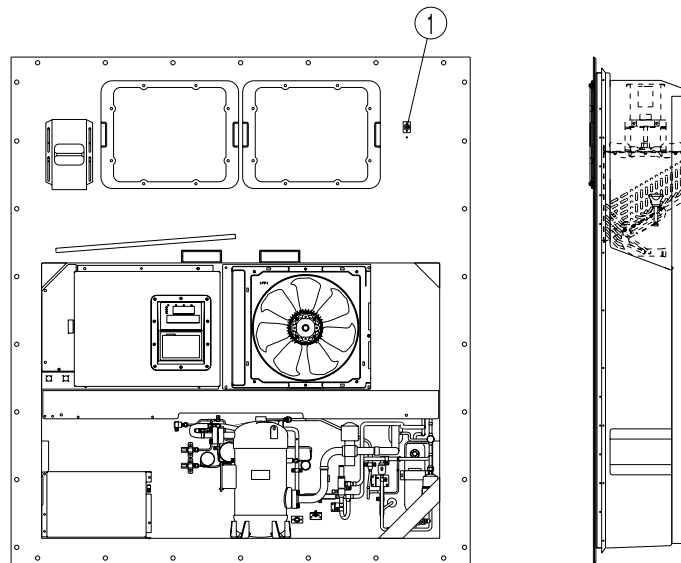

- ① Sampling port (Return) (Optional:Not equipped for A15F)

2. Transducer

2.1 Low pressure transducer (LPT)

	Transducer type	NSK-BC010F
Identification color	Transducer	Black body
	Connector	Nothing

The LPT is located in the refrigerant circuit.
The operating low pressure value is displayed on the controller indication panel.

(1) Replacing the transducer

- ① Disconnect the lead wire from the control box.
- ② In order to prevent refrigerant from flowing out, disconnect the low-pressure transducer piping from the gauge joint (with check valve) on the compressor side.
- ③ Remove two screws on the clamp plate fixing low pressure transducer in place, and cut the binding bands.

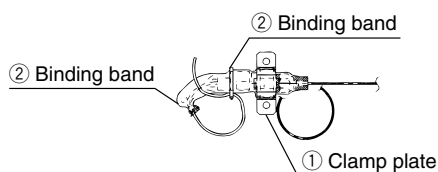

- ④ Remove the heat shrinkage tube, and disconnect the connector from the low pressure transducer.

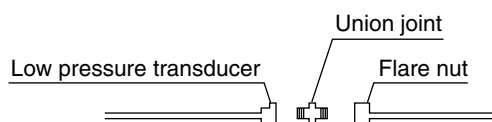

- ⑤ Insert the pressure transducer cable through the heat shrinkage tube, and connect the union joint and connector to the new low pressure transducer. If paint on the low pressure transducer is peeled off, apply clear lacquer.

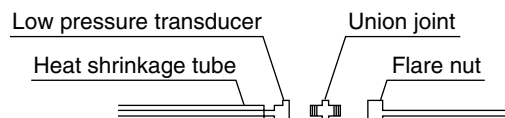

CAUTION

Do not expose the low pressure transducer to hot air of a dryer for excess time.

Otherwise, the transducer may be damaged.

- ⑥ Apply the heat shrinkage tube in the following position, then shrink it with hot air of a dryer.

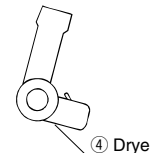
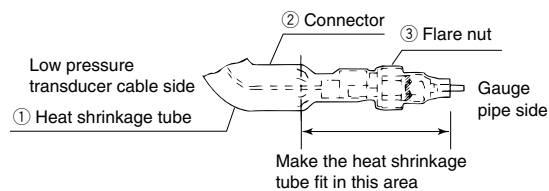

- ⑦ Apply sealer between the heat shrinkage tube and the flare nut. (Sealer :KE4898)



- ⑧ Fix the low pressure transducer with the clamp plate, and fix the cable with the binding band.

Fix the shrinkage tube end of the cable side downward for prevention of water entering into the tube.

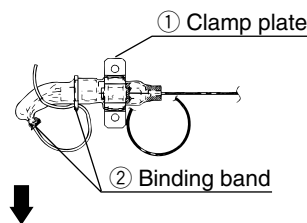

Fix the tube directing the end downward

2.2 High pressure transducer (HPT)

	Transducer type	NSK-BC030F
Identification color	Transducer	Red & Brown body
	Connector	Nothing

The HPT is located in the refrigerant circuit.
The operating high pressure value is displayed on the controller indication panel.

(1) Replacement procedure

The replacement procedure is the same as that for the low pressure transducer.
Make sure that the fixing position and the cable connection is correct.

3. Initial setting table into spare controller

MODEL NAME Note 1	※7. Optional function setting mode				※8. Basic function mode										※9. Optional Condition setting mode										※10. Input Data		
	USdA	dHu	DECOS-3	LOG INT	REC SEN	OC-SET	HP	dISP	COMP	REHEAT	FA SEN	CHARTLS	USdA1/2	H001	H002	H003	H004	H005	H006	D1--	D2--	D3--	D-1-	D-2-	C/F	SET Id	SET TIME
LXE10E	USdA	dHu	DECOS-3	LOG INT	REC SEN	OC-SET	HP	dISP	COMP	REHEAT	FA SEN	CHARTLS	USdA1/2	H001	H002	H003	H004	H005	H006	D1--	D2--	D3--	D-1-	D-2-	C/F	SET Id	SET TIME
-A15F	USdA	dHu	DECOS-3	LOG INT	REC SEN	OC-SET	HP	dISP	COMP	REHEAT	FA SEN	CHARTLS	USdA1/2	H001	H002	H003	H004	H005	H006	D1--	D2--	D3--	D-1-	D-2-	C/F	SET Id	SET TIME
-A15G	USdA	dHu	DECOS-3	LOG INT	REC SEN	OC-SET	HP	dISP	COMP	REHEAT	FA SEN	CHARTLS	USdA1/2	H001	H002	H003	H004	H005	H006	D1--	D2--	D3--	D-1-	D-2-	C/F	SET Id	SET TIME
-A15H	USdA	dHu	DECOS-3	LOG INT	REC SEN	OC-SET	HP	dISP	COMP	REHEAT	FA SEN	CHARTLS	USdA1/2	H001	H002	H003	H004	H005	H006	D1--	D2--	D3--	D-1-	D-2-	C/F	SET Id	SET TIME
Spare controller	blank	blank	blank	blank	blank	blank	blank	blank	blank	blank	blank	blank	1	3	2	2	2	3	3	1	1	1	1	1	C	blank	01/1/1

- Notes
1. Confirm MODEL NAME mentioned in the name plate mounted on the reefer unit.
 2. It is possible to input Container I.D. and Controller Time with both the panel operation and the personal computer installed DCCS's software.
 3. When inputting the container I.D. by the panel operation, take care not to enter any of the following pairs of alphabet and numeral(i-1),(O-0),(S-5).
 4. If you don't input container I.D., it is impossible to download the logger data with the personal computer.
 5. If you don't input the controller set time, it starts from 2001.1.1, 0:00.

4. Refrigerant piping diagram

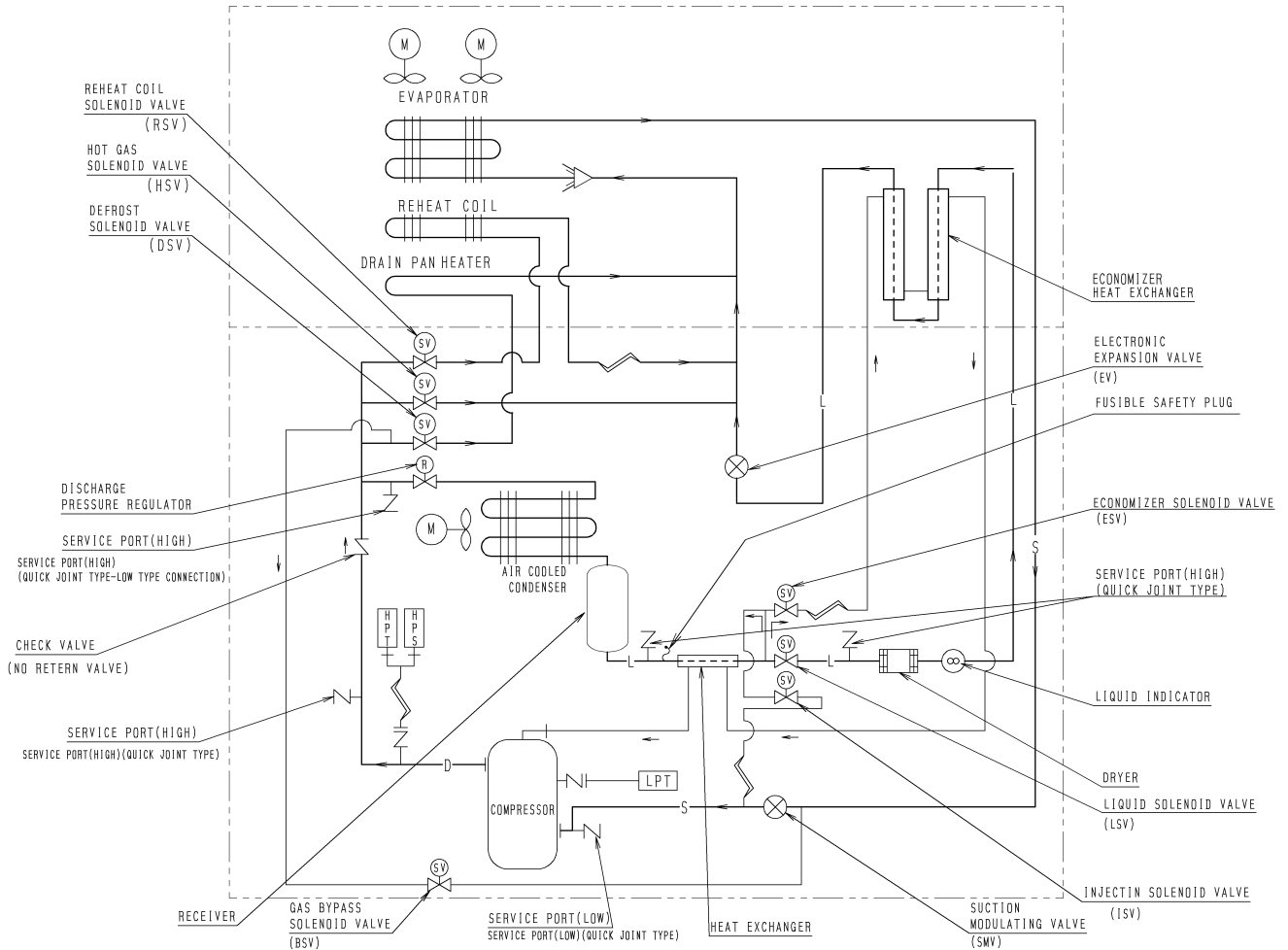

HPS	HIGH PRESSURE SWITCH
HPT	HIGH PRESSURE TRANSDUCER
LPT	LOW PRESSURE TRANSDUCER

— L —	LIQUID PIPE
— S —	SUCTION PIPE
— D —	DISCHARGE PIPE
— H —	FLANGE CONNECTION
+	FLARE CONNECTION
~	CAPILLARY TUBE

<https://daikin-p.ru>

5. Schematic wiring diagram

CONTAINER REFRIGERATION UNIT WIRING DIAGRAM

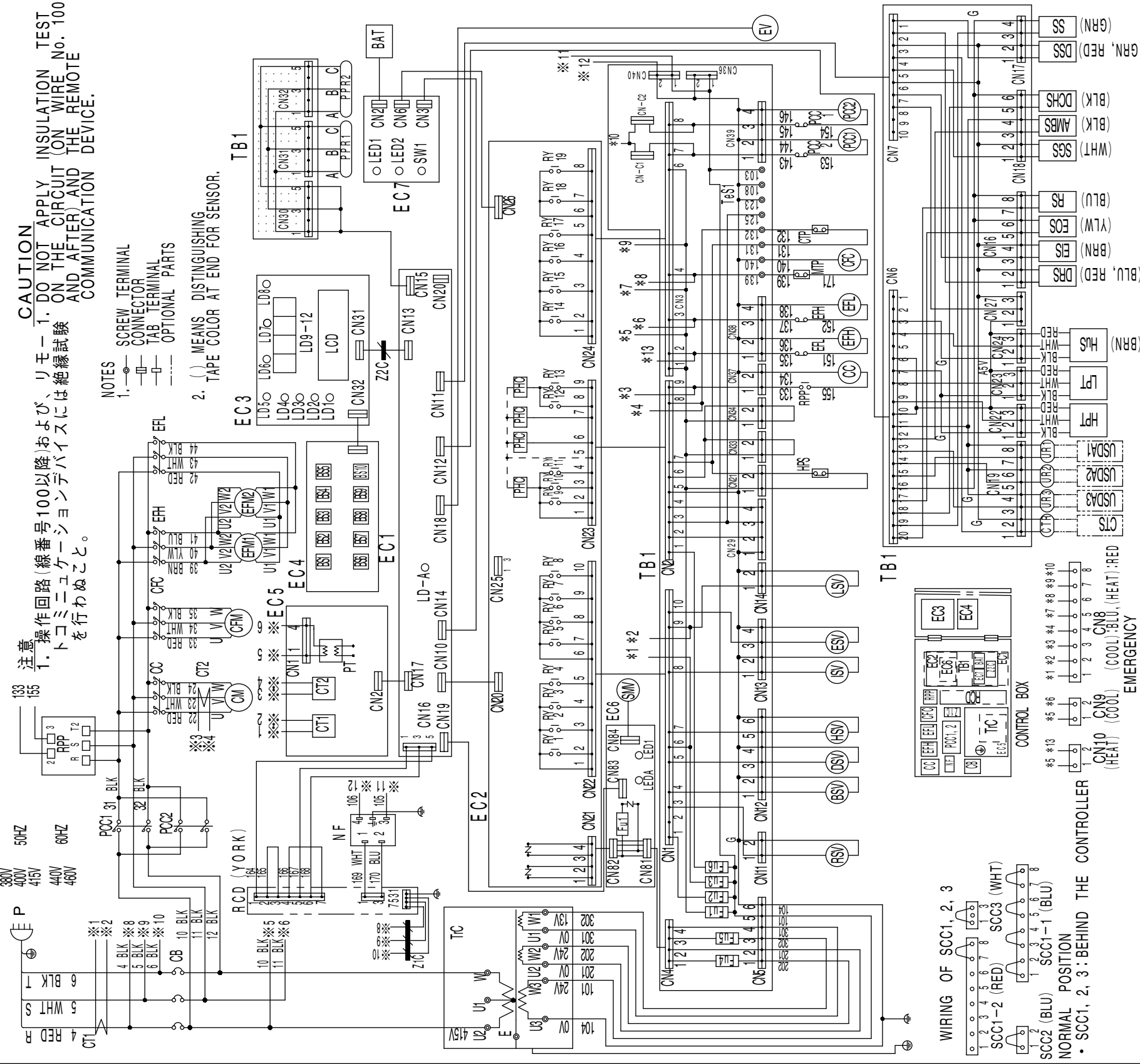

AMBS	AMBIENT TEMP. SENSOR	EC7	POWER SUPPLY BOARD	D6	LIGHT-EMITTING DIODE (DEFROST)	SCC2	SHORT CIRCUIT CONNECTOR
BAT	BATTERY	EH	HIGH SPEED EVAPORATOR FAN CONTACTOR	D7	LIGHT-EMITTING DIODE (IN RANGE)	SCC3	SHORT CIRCUIT CONNECTOR
BSV	GAS BYPASS SOLENOID VALVE	EFL	LOW SPEED EVAPORATOR FAN CONTACTOR	D8	LIGHT-EMITTING DIODE (DE-HUMID)	SGS	SUCTION GAS SENSOR
BS1-10	PUSH BUTTON SWITCH	EFM1, 2	EVAPORATOR FAN MOTOR	D9-12	LIGHT-EMITTING DIODE	SNV	SUCTION MODULATING VALVE
CB	CIRCUIT BREAKER (30A)	EIS	EVAPORATOR INLET SENSOR	LEDA	SERVICE MONITOR-GREEN (EC6)	SS	SUPPLY AIR SENSOR
CC	COMPRESSOR CONTACTOR	EOS	EVAPORATOR OUTLET SENSOR	LED1	LIGHT-EMITTING DIODE (EC6)	SW1	SWITCH BATTERY LEVEL INDICATOR
CFC	CONDENSER FAN CONTACTOR	ESV	ECONOMIZER SOLENOID VALVE	LED2	BATTERY INDICATOR (EC7)	TB1	TERMINAL BOARD
CFM	CONDENSER FAN MOTOR	EV	ELECTRONIC EXPANSION VALVE	LPT	LOW PRESSURE TRANSDUCER	TC	CONTROL TRANSFORMER
CM	COMPRESSOR MOTOR	Fu1-6	FUSE (C) (250V, 10A) (TB1)	LSV	LOW PRESSURE TRANSDUCER	URI-3	USDA RECEPTACLE
CT1, 2	CURRENT TRANSFORMER	Fu1	FUSE (C) (250V, 5A) (EC6)	MTP	COND. MOTOR THERMAL PROTECTOR	Z1C	FERRITE CORE
CTP	COMPRESSOR THERMAL PROTECTOR	HPS	HIGH PRESSURE SWITCH	NF	NOISE FILTER	Z2C	FERRITE CORE
DCHS	COMPRESSOR DISCHARGE SENSOR	HPT	HIGH PRESSURE TRANSDUCER	P	POWER PLUG		
DSS	DATA RECORDER RETURN AIR SENSOR	HSV	HOT GAS SOLENOID VALVE	PCC1, 2	PHASE CORRECTION CONTACTOR		
DSV	DATA RECORDER SUPPLY AIR SENSOR	HUS	HUMIDITY SENSOR	PHC	PHOTO COUPLER	CTS	CARGO TEMP. SENSOR
EC1	DEFROST SOLENOID VALVE	ISV	INJECTION SENSOR	PPR1, 2	PC PORT RECEPTACLE	RCD	REMOTE COMMUNICATION DEVICE (YORK) 2
EC2	L/O BOARD (DECOS)	LCD	LIQUID CRYSTAL DISPLAY	PT	POTENTIAL TRANSFORMER	USDAM1-3	USDA SENSOR
EC3	DISPLAY BOARD (DECOS)	LD-A	SERVICE MONITOR-GREEN (EC1)	RPP	REVERSE PHASE PROTECTOR		
EC4	SHEET KEY (DECOS)	LD1	LIGHT-EMITTING DIODE (R. H.)	RSV	RETURN AIR SENSOR		
EC5	PRINTED CIRCUIT BOARD (PT, CT)	LD2	LIGHT-EMITTING DIODE (ALARIM)	RS	REHEAT COIL SOLENOID VALVE		
EC6	ADAPTER BOARD	LD3	LIGHT-EMITTING DIODE (RETURN)	RY-19	RELAY		
		LD4	LIGHT-EMITTING DIODE (SUPPLY)	SCC1-1, 2	SHORT CIRCUIT CONNECTOR		
		LD5	LIGHT-EMITTING DIODE (COMP)				

OPTIONAL SPECIFICATION
 CTS CARGO TEMP. SENSOR
 RCD REMOTE COMMUNICATION DEVICE (YORK) 2
 USDAM1-3 USDA SENSOR

EACH MODEL TO EQUIP FOLLOWING OPTIONS.
 • LXE10E-A15: NONE
 • LXE10E-AS1: NO. 2

LXE10E-A15, A31

6. Stereoscopic wiring diagram

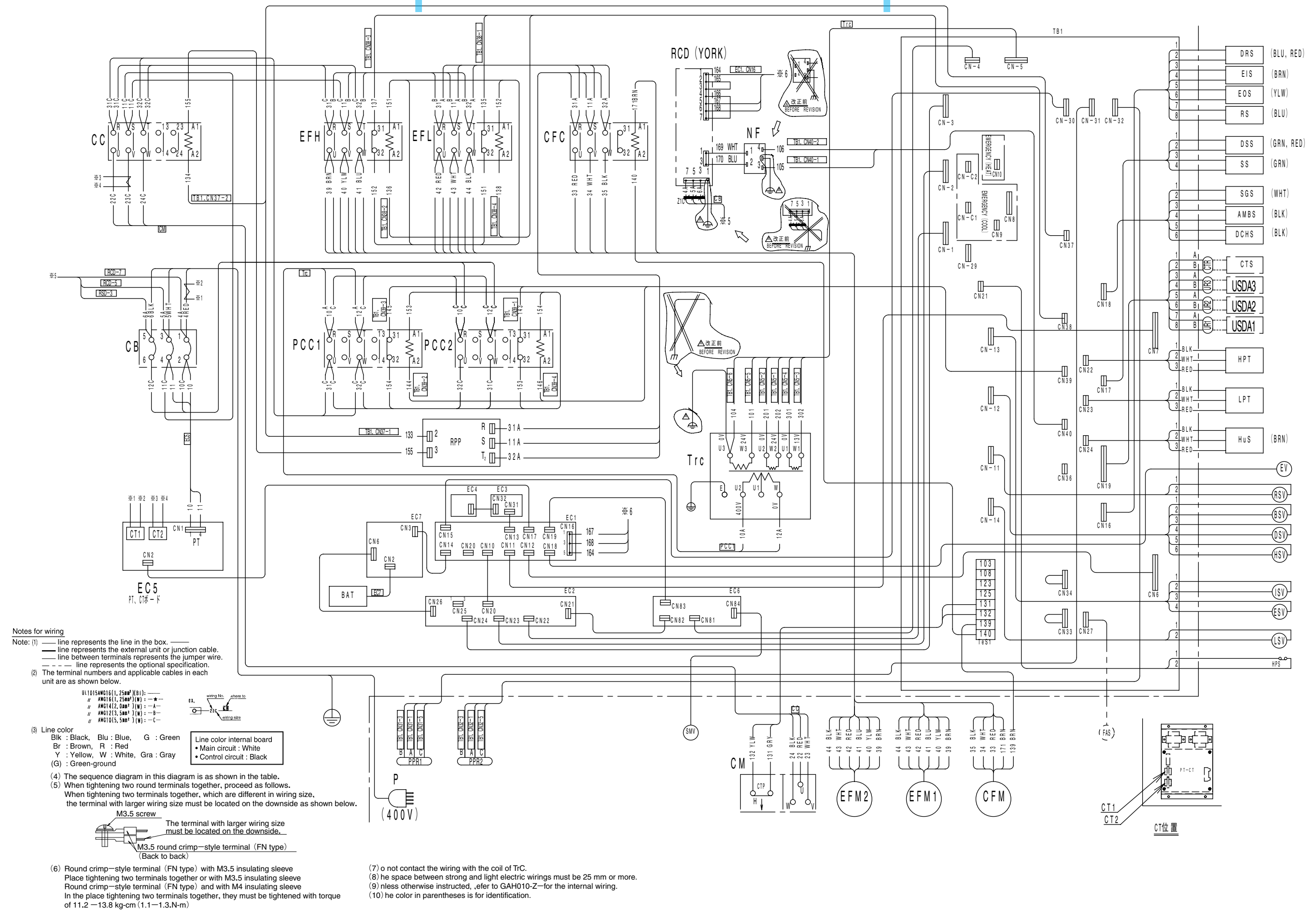

1. 部件名称

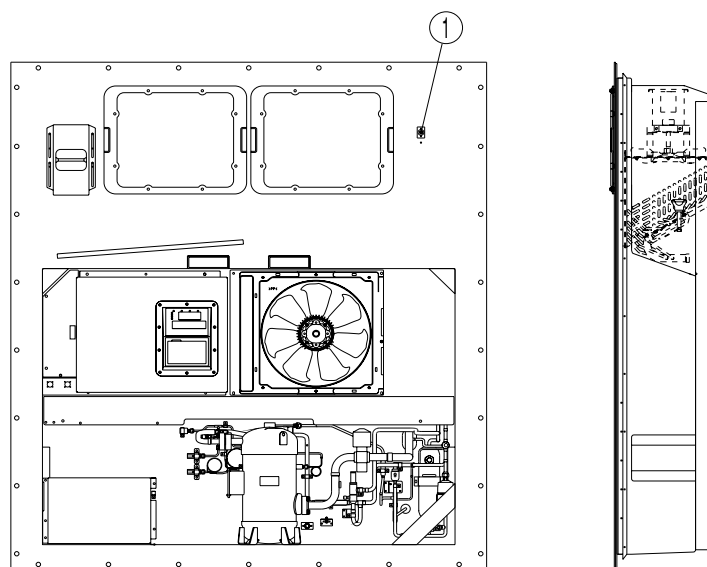

① 温度计检测口 (可选:A15F未配置)

2. 传感器

2.1 低压传感器 (LPT)

传感器型		NSK-BC010F
颜色指示	传感器	黑
	接头	没有

低压传感器位于制冷剂回路中。

运行时的低压值显示在控制器的指示面板上。

(1) 传感器的更换

- ① 断开控制箱中的引线。
- ② 为了防止制冷剂流出，应在压缩机一侧将低压传感器管与仪表接头(带止回阀)③断开。
- ③ 卸下用来固定低压传感器的夹板上的两个螺丝，接着切断绑扎带。

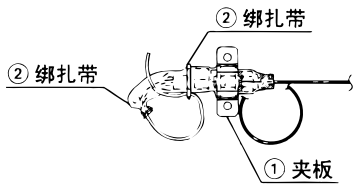

- ④ 卸下热缩管，断开接头与低压传感器的连接。

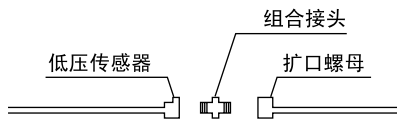

- ⑤ 将压力传感器电缆插入热缩管，接着将组合接头在新的低压传感器上。如果低压传感器上的涂层已经脱落，则应重新涂上透明漆。

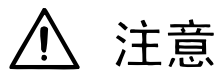
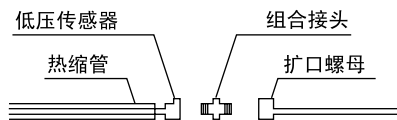

注意

请勿将低压传感器暴露在干燥器的热气中过长时间，否则会损坏传感器。

- ⑥ 将热缩管放在如下位置，接着用干燥器的热气使之收缩。

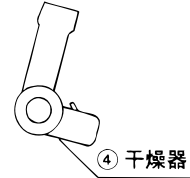
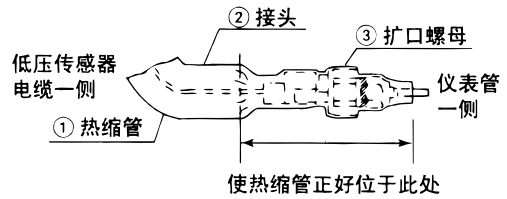

- ⑦ 将密封件放在热缩管与扩口螺母之间。(密封件：KE4898)

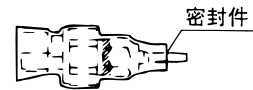

- ⑧ 用夹板固定住低压传感器，接着用绑扎带固定住电缆。应使电缆一侧的热缩管端头朝下以防止水进入管中。

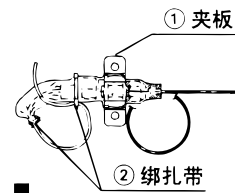

固定热缩管时应使其端头朝下

2.2 高压传感器 (HPT)

传感器型		NSK-BC030F
颜色指示	传感器	红、茶
	接头	没有

高压传感器位于制冷剂回路中。

运行时的高压值显示在控制器的指示面板上。

(1) 更换步骤

更换步骤与低压传感器相同。

应确保固定位置及电缆连接正确。

3. 备用控制器的初始设定表

型号名称 注1	※7. 选项功能 设定模式			※8. 基本功能模式										※9. 选项条件设定模式										※10. 输入数据					
	USdA	dHu		DECO3	LOG INT	REC SEN	OC-SET	HP	dlSP	COMP	REHEAT	FASEN	CHARTLS	USdA1/2	H001	H002	H003	H004	H005	H006	D1--	D2--	D3--	D-1-	D-2-	CF	SET Id	SET TIME	
LXE10E	USdA	除湿 控制		控制器 设定	记录 间隔	数据记 录器传 感器	输入 电源	马力	面板指 示灯 OFF	压缩机 /卸载 设定	再热盘 管设定		D/H代 码报警 显示	USdA传 感器 类型														集装箱 箱号	控制器 设定 时间
-A15F														2	3	2	2	2	3	3	1	1	1	1	1		*	GMT	
-A15G	OFF	OFF	D	60	ON	ON	单相	10	OFF	100	ON	ON																	
-A15H																													
备用控 制器	空白	空白	空白	空白	空白	空白	空白	空白	空白	空白	空白	空白	空白	1	3	2	2	2	3	3	1	1	1	1	1	C	空白	01/1/1	

注 1. 确认制冷机组铭牌(安装在机组上)上的型号名称。
 2. 可通过面板操作和个人电脑安装的DCCS软件输入集装箱号和控制器时间。
 3. 通过操作面板输入集装箱号时, 注意不要输入下述字符: (i-1)、(O-0)、(S-5)。
 4. 如果不输入集装箱号, 则无法用个人电脑下载记录的数据。
 5. 如果不输入控制器设定时间, 则从2001年1月1日0:00开始。

4. 系统管路图

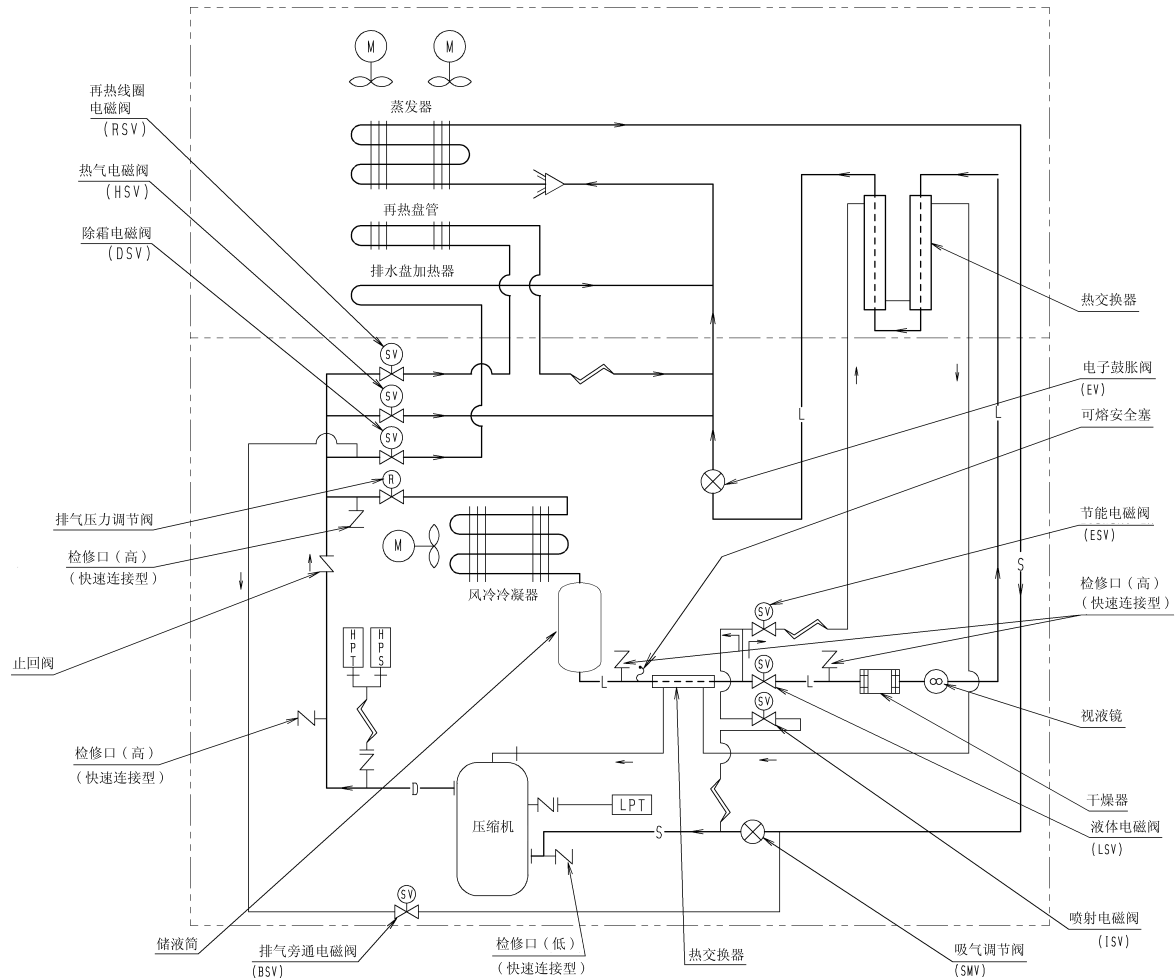

HPS	高压开关
HPT	高压传感器
LPT	低压传感器

— L —	液体管
— S —	吸水管
— D —	排水管
— H —	法兰连接
— + —	扩口管连接
— 〰 —	毛细管

集装箱制冷机组配线图

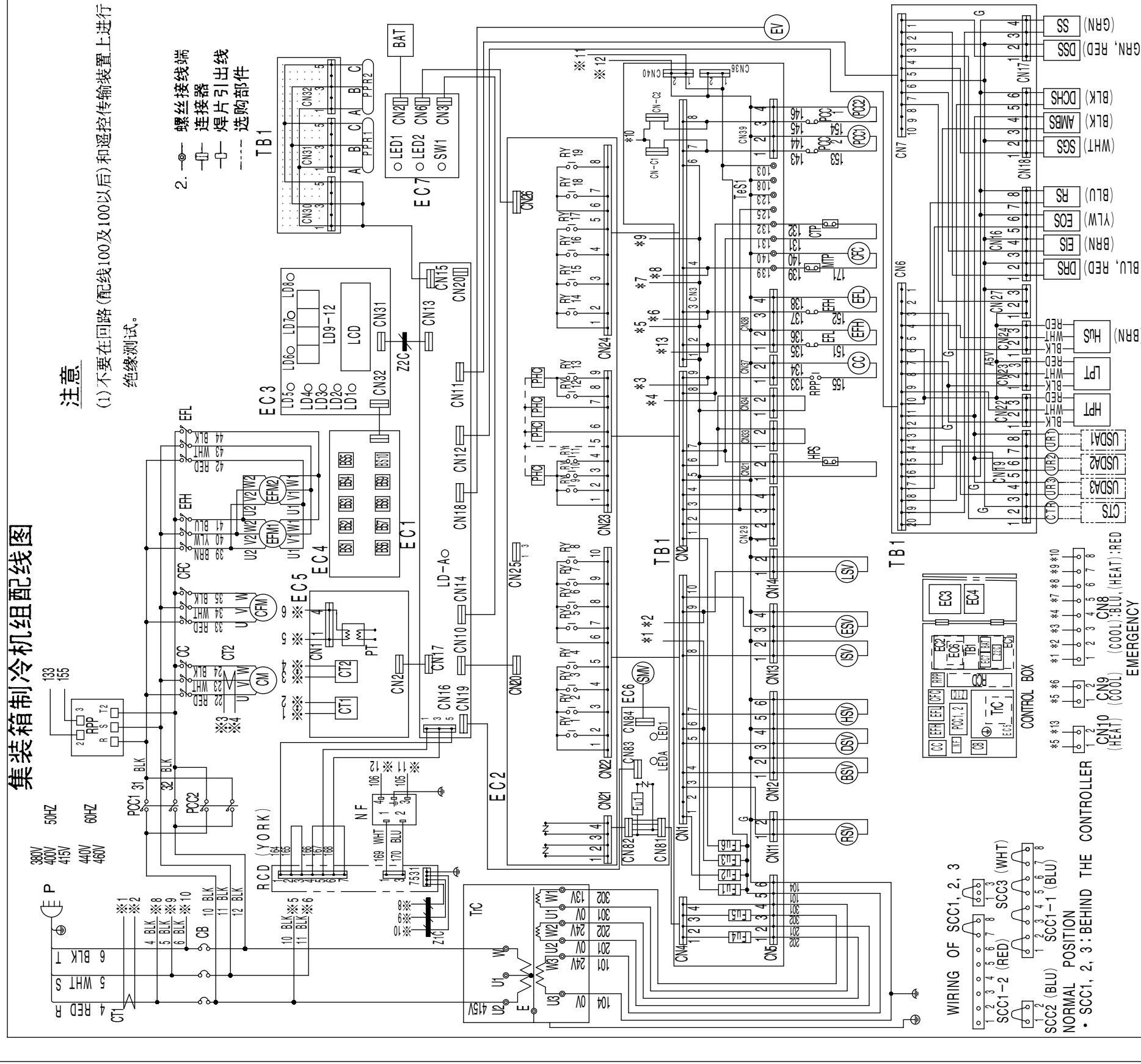

注意

(1) 不要在回路(配线100及100以后)和遥控传输装置上进行绝缘测试。

2. 螺丝接线端
 连接器
 焊片引出线
 选购部件

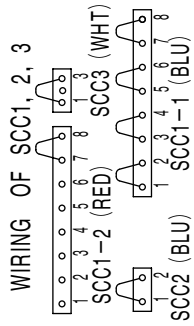

AMS	AMBIENT TEMP. SENSOR	D6	LIGHT-EMITTING DIODE (DEFROST)
BAT	BATTERY	D7	LIGHT-EMITTING DIODE (IN RANGE)
BSV	GAS BYPASS SOLENOID VALVE	D8	LIGHT-EMITTING DIODE (DE-HUMID)
BS1-10	PUSH BUTTON SWITCH	LD9-12	LIGHT-EMITTING DIODE
CB	CIRCUIT BREAKER (3A)	LEDA	SERVICE MONITOR-GREEN (EC6)
CC	COMPRESSOR CONTACTOR	LED1	LIGHT-EMITTING DIODE (EC6)
CFM	CONDENSER FAN MOTOR	LED2	BATTERY INDICATOR (EC7)
CM	COMPRESSOR MOTOR	LPT	LOW PRESSURE TRANSDUCER
CT1, 2	CURRENT TRANSFORMER	LSV	LIQUID SOLENOID VALVE
CTP	COMPRESSOR THERMAL PROTECTOR	MTP	COND. MOTOR THERMAL PROTECTOR
CTS	CARGO TEMP. RECEPTACLE	NF	NOISE FLIER
DCHS	COMPRESSOR DISCHARGE SENSOR	P	POWER PLUG
DRS	DATA RECORDER RETURN AIR SENSOR	PCC1, 2	PHASE CORRECTION CONTACTOR
DSV	DATA RECORDER SUPPLY AIR SENSOR	PHC	PHOTO COUPLER
DSV	DEFROST SOLENOID VALVE	PPR1, 2	PC PORT RECEPTACLE
EC1	CPU BOARD (DECOS)	PT	POTENTIAL TRANSFORMER
EC2	I/O BOARD (DECOS)	RPP	REVERSE PHASE PROTECTOR
EC3	DISPLAY BOARD (DECOS)	RS	RETURN AIR SENSOR
EC4	SHEET KEY (DECOS)	RSV	REFEAT COIL SOLENOID VALVE
EC5	PRINTED CIRCUIT BOARD (PT. CT)	Rvt-19	RELAY
EC6	ADAPTER BOARD	SCC1-1-2	SHORT CIRCUIT CONNECTOR
		SCC2	SHORT CIRCUIT CONNECTOR
		SCC3	SHORT CIRCUIT CONNECTOR
		SGS	SUCTION GAS SENSOR
		SNV	SUCTION MODULATING VALVE
		SS	SUPPLY AIR SENSOR
		SW1	SWITCH BATTERY LEVEL INDICATOR
		TB1	TERMINAL BOARD
		TIC	CONTROL TRANSFORMER
		URI-3	USDA RECEPTACLE
		Z1C	FERRITE CORE
		Z2C	FERRITE CORE
			OPTIONAL SPECIFICATION
		CTS	CARGO TEMP. SENSOR
		RCD	REMOTE COMMUNICATION DEVICE (YORK)
		USDM1-3	USDA SENSOR
			OPTIONAL ITEM NO.
			EACH MODEL TO EQUIP FOLLOWING OPTIONS.
			• LXE10E-A15: NONE
			• LXE10E-AS1: NO. 2
			LXE10E-A15, A31

2 D 0 3 2 9 3 - 1 B

6. 配线立体图

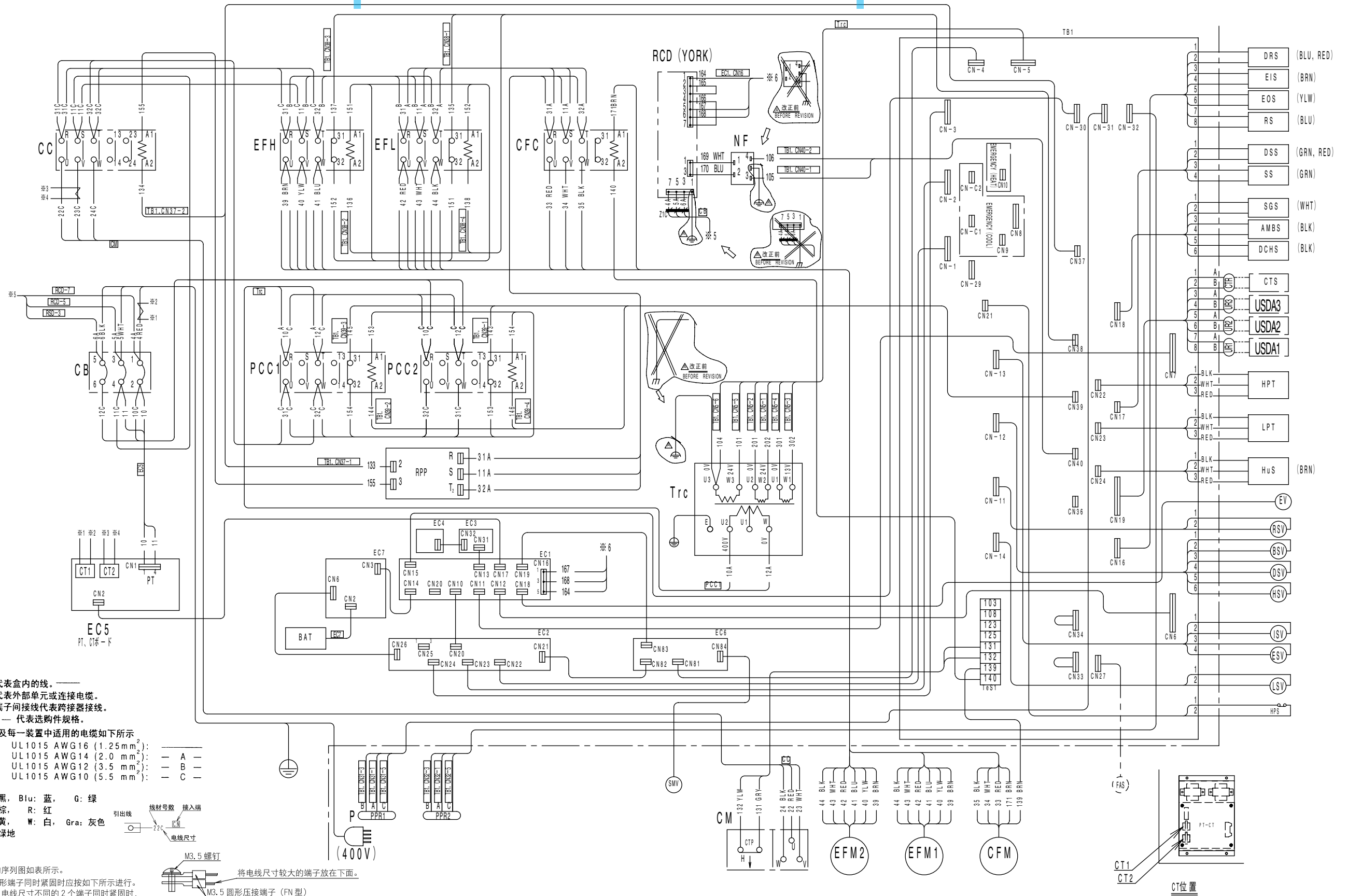

配线注解

- 注(1) ——— 代表盒内的线。
 ——— 代表外部单元或连接电缆。
 ——— 端子间接线代表跨接器接线。
 - - - - 代表选配件规格。

- (2) 端子号及每一装置中适用的电缆如下所示
 UL1015 AWG16 (1.25mm²): — A —
 UL1015 AWG14 (2.0mm²): — B —
 UL1015 AWG12 (3.5mm²): — C —
 UL1015 AWG10 (5.5mm²): — C —

- (3) 线颜色
 Bl: 黑, Blu: 蓝, G: 绿
 Br: 棕, R: 红
 Y: 黄, W: 白, Gra: 灰色
 (G): 绿地

- (4) 该图的序列图如表所示。
 (5) 2个圆形端子同时紧固时应按如下所示进行。
 另外, 电线尺寸不同的2个端子同时紧固时,
 应按如下所示将电线尺寸较大的端子放在下面。
 (6) 在2个M3.5带绝缘套圆形压接端子(FN型)同时紧固部位, 或1个M3.5带绝缘套圆形压接端子(FN型)
 和1个M4带绝缘套圆形压接端子(FN型)同时紧固部位, 应以扭矩11.2~13.8kg·cm(1.1~1.3N·m)进行紧固。
 (7) 配线不可接触TrC的线圈。
 (8) 强电配线与弱电配线之间应间隔25mm以上。
 (9) 无指示部位的装置内配线按GAHO10-Z规格进行。
 (10) () 内的颜色代表识别色。

ORDERING INSTRUCTIONS

The parts list contains the parts of the DAIKIN Marine Type Container Refrigeration Units. Please read the following items before using the list.

1. When ordering the parts, be sure to specify the model No., the name of part and the type of part. When ordering the parts for which no parts NO. is shown in the PARTS NO. column, be sure to describe DWG.NO..
2. The list shows the parts only for replacement or repairing at the job site. Certain parts require a production lead time or are supplied as a set, so please contact with the nearest DAIKIN PARTS CENTRE.

3. Index symbols;

Meaning of the ranking A,B and C are as follows;

A. The most important spare parts

1. The parts whose malfunction cause fatal damage to the unit.
2. The parts with high risk of malfunction.
3. The parts that are worn out after an extended service period.

B. The important spare parts next to A, but the risk of malfunction is not so high.

C. The parts with low risk of malfunction, but recommendable to stock to cope with damage during handling of container box and long delivery time, etc.

The parts without A, B and C mark is the parts whose necessity is not so high under normal operation.

パーツリスト使用上の注意

このパーツリストはダイキン海上コンテナ冷凍装置の部品を集録してあります。パーツリスト使用にあたっては、必ず次の注意事項をご一読の上使用していただくようお願いいたします。

1. 部品のご注文の際は機種名、部品番号、および部品名、形式を必ずご指定ください。
なお、部品番号欄が空白になっている部品は、図面番号で指示願います。
2. 掲載部品の範囲は、あくまでも現地にて分解修理できるところまで記載しております。
一部部品につき納期のかかるものおよびセット単位となるものもありますので、お近くのダイキンパーツセンター又はサービスステーションに相談願います。
3. INDEXの説明
INDEXのA、B、Cの意味は下記の通りです。
A. 最も重要な部品
 1. 故障した場合に最も重大な損害を与えると思われる部品
 2. 故障の確率が高いと思われる部品
 3. 長期の使用で摩耗して使用できなくなる部品
B. 故障発生の確率は高くはないが、Aについて重要な部品
C. 故障発生の確率は低いですが、コンテナボックスの運搬中の事故や、部品の納期が長期になるとと思われる等の理由で、在庫をお勧めする部品
A,B,Cマークの無い部品は、通常の運転では必要性は高くない部品です。

Denomination of Model Name

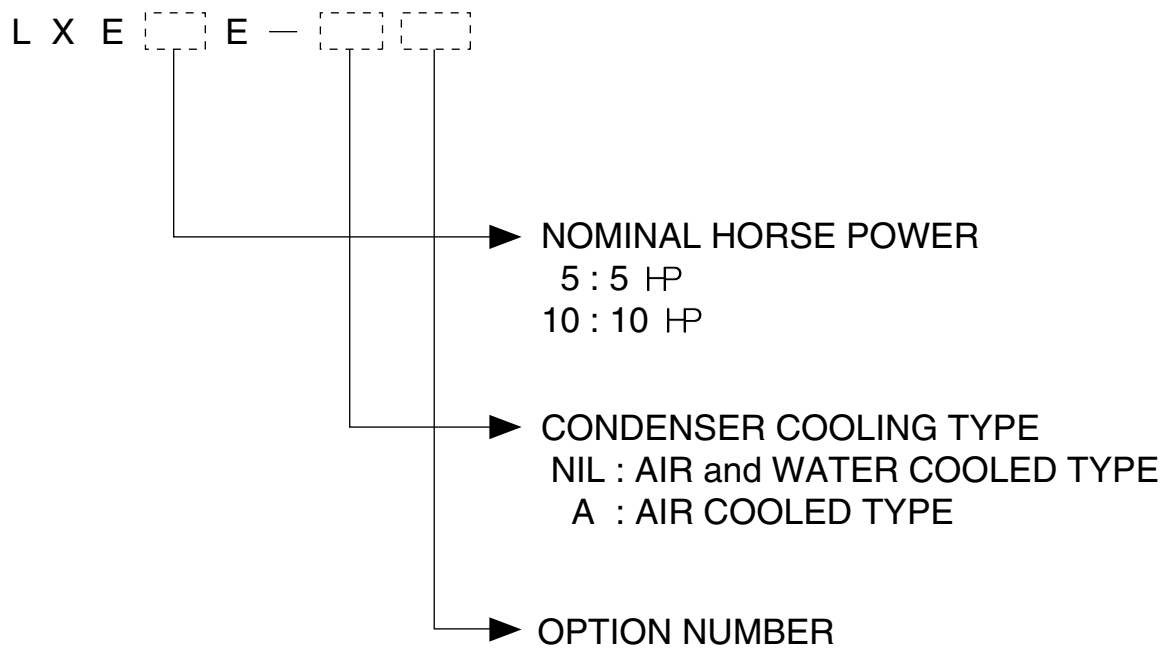

Note) "R" GIVEN AFTER OPTION NUMBER STANDS FOR "REVISION" AND IT IS GIVEN FOR THE UNIT WHICH IS SPECIALLY MODIFIED.

機種名について

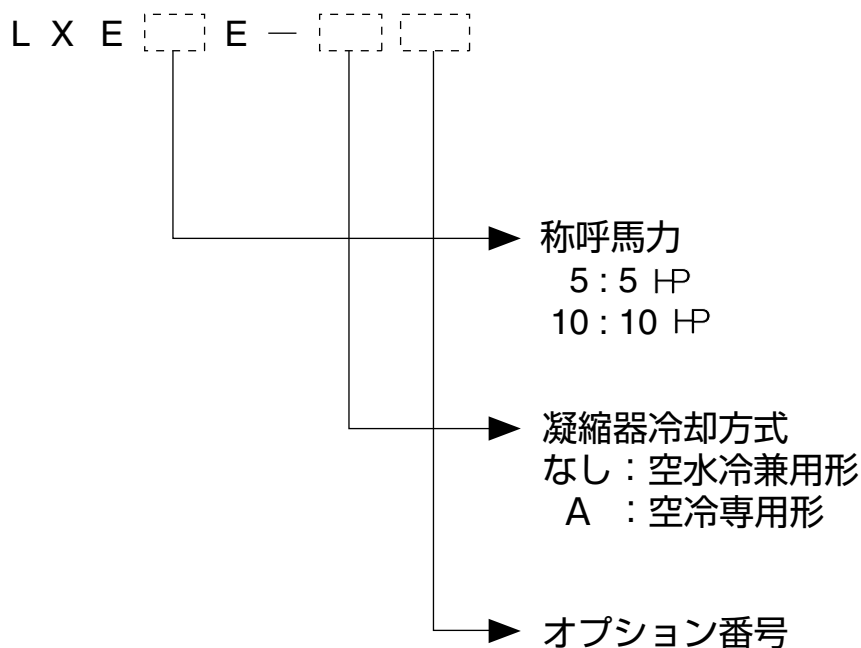

注) オプション番号の後に R がつく機種は、改造機で、特別な仕様が加えられていることを意味します。

	Page
A. Parts related with the unit(outside)	20
庫外関連部品	
B. Parts related with refrigerant piping(outside)	22
庫外冷媒配管関連部品	
C. Parts related with the unit(inside)	26
庫内関連部品	
D. Parts related with refrigerant piping(inside)	30
庫内冷媒配管関連部品	
E. Other parts(Pipe clamp, sealing and insulation material etc.)	32
その他部品 (配管固定具、シール材、防熱材等)	
F. Control box	40
コントローラボックス	
G. Parts related with name plate	48
銘板関連	
I. Parts related with option 1 – USDA	50
オプション関連部品 1 - USDA関連	
J. Parts related with option 2 – MODEM	52
オプション関連部品 2 - モデム	
K. Parts related with option 3 – Others	54
オプション関連部品 3 - その他	
1. Indoor fan guard 庫内ファンガード	
2. Evaporator coil 蒸発器コイル組立品	
L. List of size for standard pipe clamp	56
配管固定具サイズ表	
1. Resin clamp 樹脂バンド	
2. Tube clamp 管止金	
3. Cushion rubber for pipe clamp 管止金用緩衝ゴム	
M. Note for ordering spare parts	58
部品発注の際の注意事項	
1. Parts recommended to be ordered together with packing, gasket, sealing material and name plate	
発注の際にパッキングやシール材、銘板等の同時発注を推奨する部品	
2. Order for motorized valve, solenoid valve and pressure regulating valve	
電動弁・電磁弁・圧力調整弁の発注	
3. Order for pressure transducer 圧力センサーの発注	
4. Order for temperature sensor 温度センサーの発注	
N. Measuring and adjusting tools	63
測定調整用工具	
1. Tools for emergency operation 緊急運転用工具	
2. Personal computer cable (for DCCS) パソコンケーブル(DCCS用)	

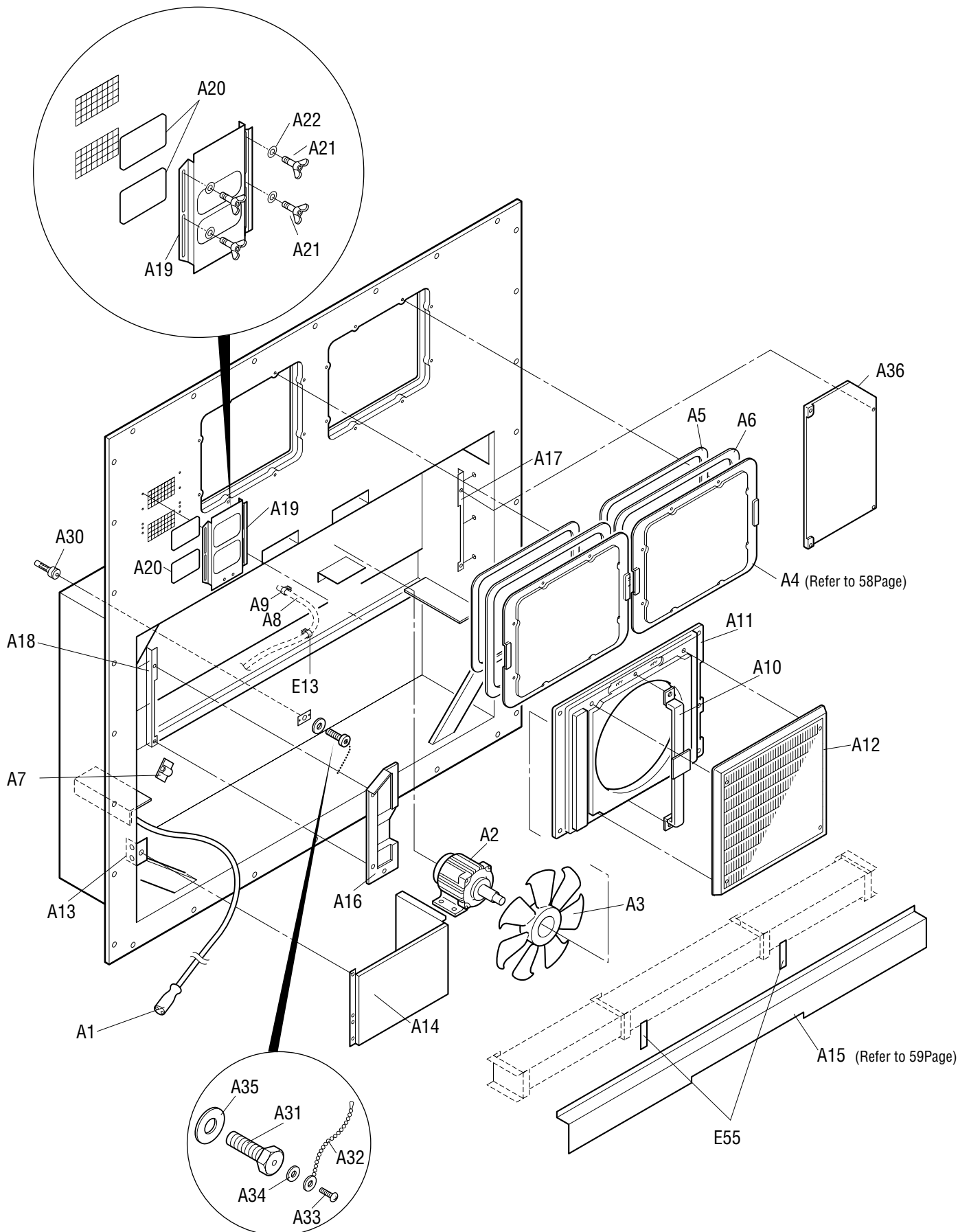

NO. 符号	INDEX	PARTS NO. 部品番号	PARTS NAME	部品名称	DWG. NO. 図面番号	TYPE SPECIFICATION 形式 仕様	QTY/UNIT			REMARKS 備考
							LXE10E-			
							A15F	A15G	A15H	
A1		1448270	Power plug	電源プラグ	3P109727-1		1	1	1	
A2	A	0954936	Condenser fan motor	凝縮器電動機	3P005566-1		1	1	1	
A3	B	0980618	Fan Brade(outside)	プロペラファン (庫外側)	2P004956-1	P44H11S	1	1	1	
A4	C	1612576	Access panel(FRP)	サービス扉組立品	1P006678-5		2	2	2	Refer to Page58
A5		1266207	Cushion material(access panel)	クッション材 (サービス扉)	3P033608-1		2	2	2	Refer to Page58
A6		1196113	Sealing material(access panel)	シール材 (サービス扉)	3P001640-2		2	2	2	Refer to Page58
A7		1326705	Wire clamp	電線止め金	4P090422-1		1	1	1	
A8	C	1266199	Drain hose	ドレンホース	3P011299-1	For trap type	1	1	1	
A9		537320	Hose band	ホースバンド	R4716528-3		2	2	2	
A10		1266137	Fan guide stay ass'y(outside)	ファンガイドステー組立品(庫外側)	3P027891-1		1	1	1	
A11		1588356	Fan guide(outside)	ファンガイド (庫外側)	1P050906-6		1	1	1	
A12	C	1588349	Discharge grill	吹出グリル	1PA53427-6		1	1	1	
A13		1369663	Mounting plate 2, cable storage	ケーブル収納部取付板 2	4P006981-2		1	1	1	
A14		1564660	Cabel holding sheet metal	ケーブル収納部板金(圧縮機前板:有/無共用)	3P128458-1		1	1	1	
A15	C	1661299	Front plate(CA)	前板 (C A)	2P165976-1		1			Refer to Page59
A15		1739286	Front plate(CA)	前板 (C A)	2P173133-1			1	1	Refer to Page59
A16		1600504	C,BOX Front plate	コントロールボックス前板(左)	2P093861-5		1	1	1	
A17		1661338	Fixing plate	外板取付板 (1)	3P170539-1		1	1	1	
A18		1661321	Fixing plate	外板取付板 (2)	3P170535-1		1	1	1	
A19	B	0981060	Ventilation cover	換気口蓋	3P003175-1		1	1	1	Refer to Page59
A20		1266221	Sealing material(ventilator)	シール材 (換気口)	4P016185-1		2	2	2	Refer to Page59
A21		1775446	Wing bolt	蝶ボルト	4P048681-2		4	4	4	
A22		0275145	Plain washer(Woods round type)	平座金 (木材用丸)	4SK07006-6	M6	4	15	15	
A30		1496820	Protection cover(2)	温度計挿入口保護カバー (2)	4P085921-2		1	1	1	
A31		1266238	Hexagon head bolt	P C六角ボルト	R4290921-125	M12X25	1	1	1	
A32		1386930	Latch(victor chain)	掛金 (ビクターチェーン)	4P063801-1		1	1	1	
A33		1775453	Tapping screw	タッピンネジ	4SK05064-10		1	1	1	
A34		844012S	Plain washer	平座金	4SK07005-3	M3SUS	1	22	22	
A35		1267084	Gasket, resin bolt	パッキン樹脂ボルト用	4PA63573-1		1	1	1	
A36		1679416	Front panel(right)	前板 (右)	3P173348-1		1	1	1	
E13		1266788	Resin clamp	樹脂バンド	NE41015-12	MILK WHITE	6	6	6	
E55		1267077	Packing for prevention of vibration	C A前板ビビリ防止パッキン	4P050050-1		2	2	2	

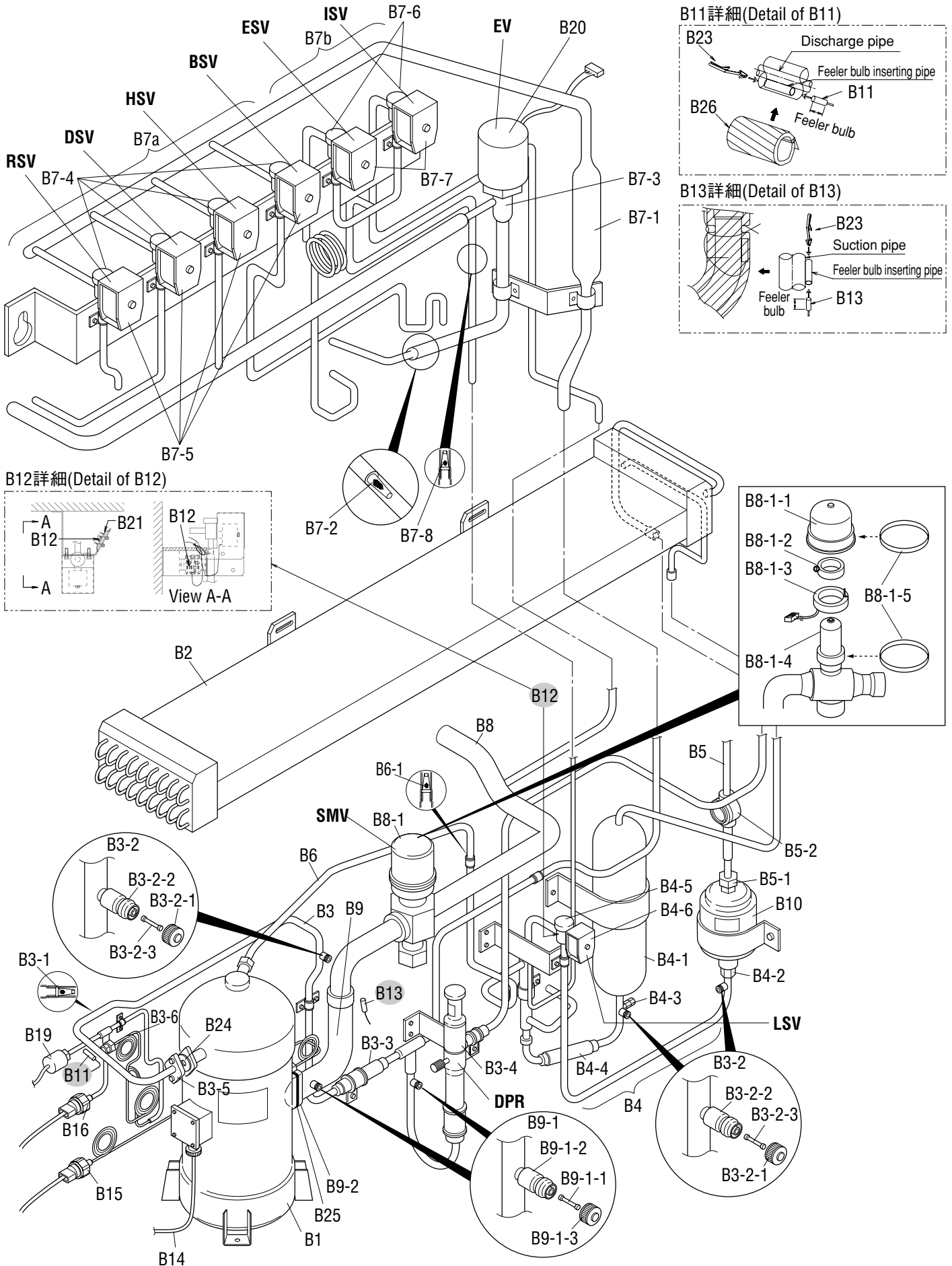

NO. 符号	INDEX	PARTS NO. 部品番号	PARTS NAME 部品名称		DWG. NO. 図面番号	TYPE SPECIFICATION 形式 仕様	QTY/UNIT			REMARKS 備考
							LXE10E-			
							A15F	A15G	A15H	
B1	A	1199415	Compressor	圧縮機	JT224D-NYR		1	1	1	
B2	C	1387173	Air cooled condenser	空冷凝縮器	2P089486-1	CA-LXE10E1	1	1	1	
B3			Discharge pipe ass'y	吐出配管組立品	2P117329-1		1	1	1	
B3-1	C	1199167	Strainer	ストレーナ	4P051389-1		1	1	1	
B3-2	C	1178920	Service valve ass'y	サービスバルブ組立品	3P048905-1		3	3	3	
B3-2-1	B	117592J	Service valve cap	キャップ	3P048905-1-KU		3	3	3	
B3-2-2	B		Service valve body	本体	3P048905-1-KA		3	3	3	
B3-2-3	B	1178850	Valve core	バルブコア	3P048905-1-KI		3	3	3	
B3-3	B	0684220	Check valve	逆止弁	3SA27008-1		1	1	1	
B3-4	A	1241361	Discharge pressure regulating valve	吐出圧力調整弁	3P074558-1		1	1	1	Refer to Page60
B3-5		1266276	Flange(convex)	吐出管フランジ (凸)	4P065933-1		1	1	1	
B3-6	B	292011	Gauge joint(with check valve)	逆止弁付ゲージ接手	2PF00177-1	VCG2DA	1	1	1	
B4			Liquid receiver ass'y	受液器組立品	2P162878-2		1	1	1	
B4-1		1266283	Liquid receiver	受液器レシーバ	4P081428-1	φ 90×t1.8	1	1	1	
B4-2		013785J	Flare nut	フレアナット	4SK23011-4	FNS4 φ 12.7	1	1	1	
B4-3	A	1498035	Fusible plug	可熔栓	3SA27103-1		1	1	1	
B4-4		0299134	Filter	フィルタ	3SA26004-2		1	1	1	
B4-5	B	1787247	Solenoid valve body	電磁弁本体	3P198486-1	VPV-803DQ52	1	1	1	Refer to Page60
B4-6	A	0955287	Solenoid valve coil	電磁弁コイル	3P010453-1		1	1	1	Refer to Page60
B5			Liquid pipe ass'y	液配管組立品	3P162887-1		1	1	1	
B5-1		013785J	Flare nut	フレアナット	4SK23011-4	FNS4 φ 12.7	1	1	1	
B5-2	A	0622107	Liquid moisture indicator	モイスタチャーインジケーター	3PA51270-3	SGN12S	1	1	1	
B6			Injection tube ass'y	インジェクション管組立品	3P162892-1		1	1	1	
B6-1	C	0085296	Strainer	ストレーナ (100メッシュ)	R4697892		1	1	1	
B7a			Expansion valve pipe ass'y	膨張弁配管組立品	2P163079-3		1	1	1	
B7-1	C	1505748	Filter	フィルタ	3P011071-1		1	1	1	
B7-2	C	1490846	Strainer	ストレーナ	4P051958-1		1	1	1	
B7-3	A	125649J	Electronic expansion valve body ass'y	電子膨張弁本体組立品	2SA50010-2-KU		1	1	1	Refer to Page60
B7-4	B	1787247	Solenoid valve body	電磁弁本体	3P198486-1	VPV-803DQ52	4	4	4	Refer to Page60
B7-5	A	1266290	Solenoid valve coil	電磁弁コイル	3P010453-2		4	4	4	Refer to Page60
B7b			ISV,ESV pipe ass'y	I S V ・ E S V 配管組立品 (標準・P&O)	3P163059-2		1			
B7b			ISV,ESV pipe ass'y	I S V ・ E S V 配管組立品	3P178353-2			1	1	
B7-6	A	0088738	Nev type solenoid valve body	N E V 型電磁弁本体	R3305099-1-KI	NEV-202DXF	2	2	2	Refer to Page60
B7-7	A	1266290	Solenoid valve coil	電磁弁コイル	3P010453-2		2	2	2	Refer to Page60
B7-8	C	0964166	Strainer	ストレーナ	4P012568-1		1	1	1	
B8		1496781	Suction pipe ass'y(inside)	吸入配管組立品 (庫内)	3P071569-2		1	1	1	
B8-1	A	1254538	Suction modulating valve ass'y	吸入比例弁組立品	2P078385-1		1	1	1	Refer to Page60
B8-1-1		1270376	Upper cover, suction modulating valve	吸入比例弁カバー上	2P078385-1-KA		1	1	1	
B8-1-2		1496914	Clamp, suction modulating valve	吸入比例弁クランプ	2P078385-1-KI		1	1	1	
B8-1-3		1270390	Coil, suction modulating valve	吸入比例弁コイル	2P078385-1-KU		1	1	1	

● When ordering the parts whose No. are not shown in the PARTS NO. column, be sure to describe DWG. NO..

● 部品番号欄が空白になっている部品は、図面番号で、指示願います。

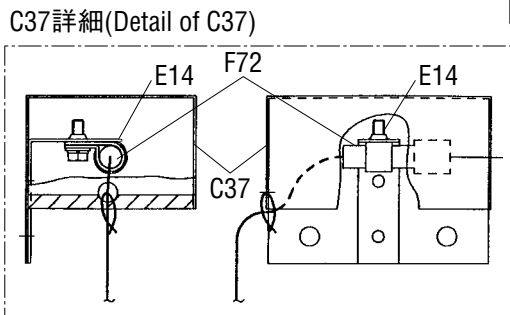
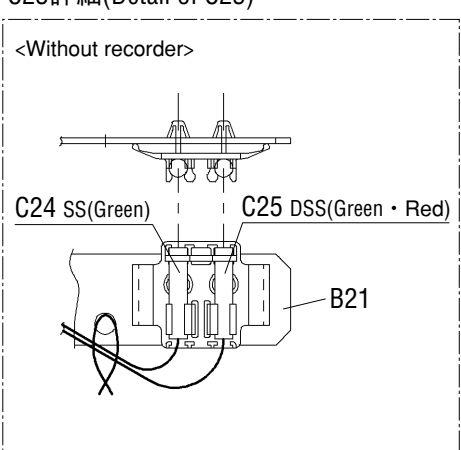
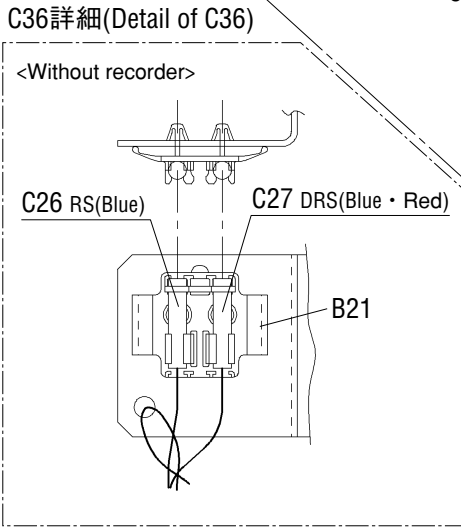
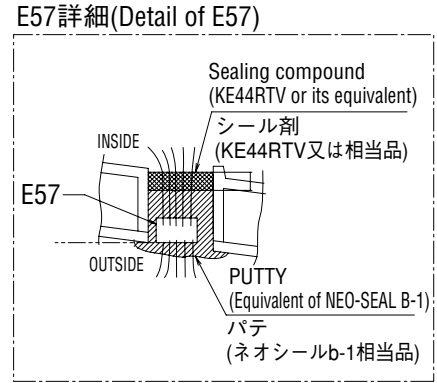
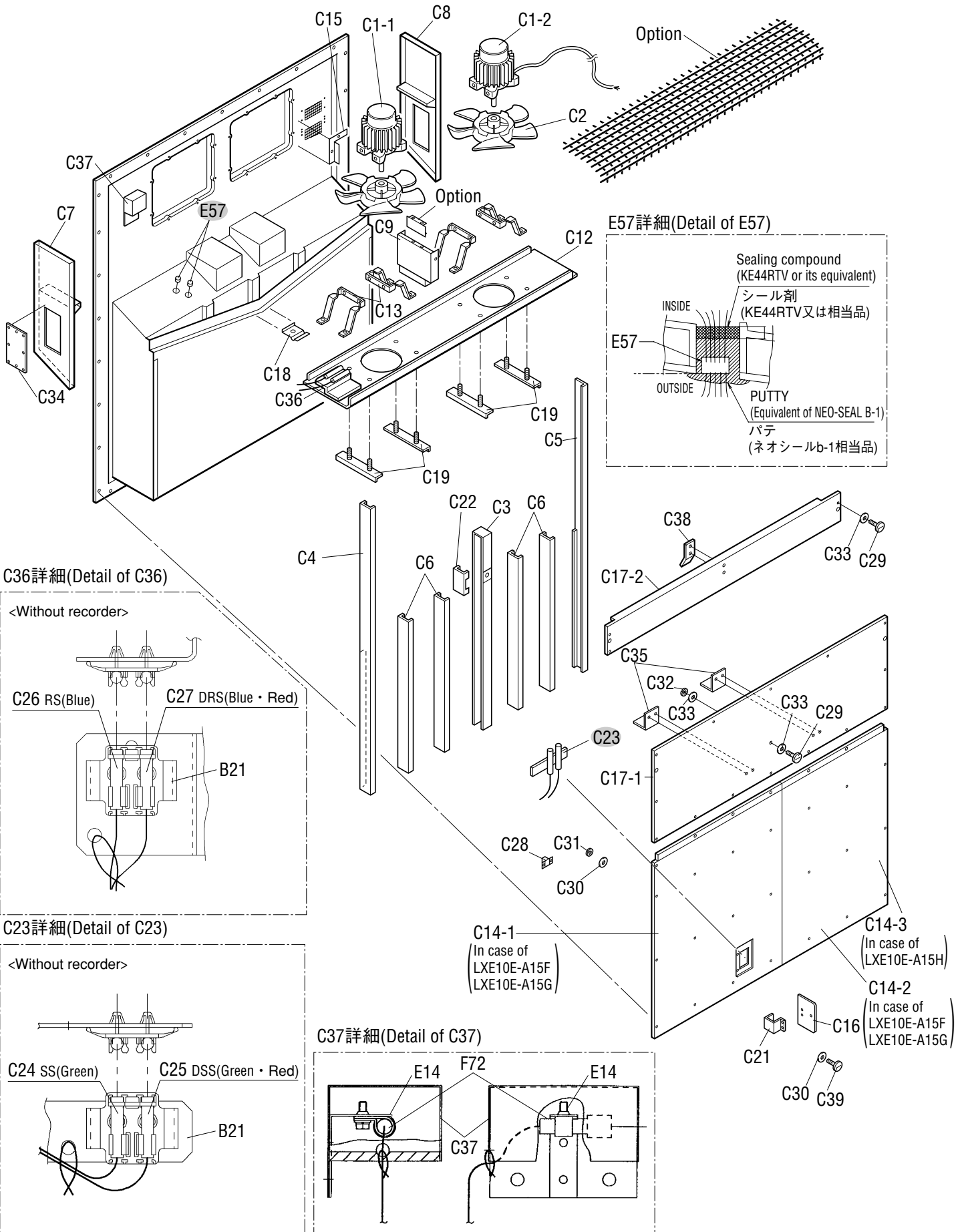

NO. 符号	INDEX	PARTS NO. 部品番号	PARTS NAME	部品名称	DWG. NO. 図面番号	TYPE SPECIFICATION 形式 仕様	QTY/UNIT			REMARKS 備考
							LXE10E-			
							A15F	A15G	A15H	
C1-1	A	0955340	Three phase AC fan motor	三相交流ファン電動機	3PA07524-5	SPRK91A-42	1	1	1	
C1-2	A	0955333	Three phase AC fan motor	三相交流ファン電動機	3PA07524-4		1	1	1	
C2	B	0777519	Fan brade(inside)	プロペラファン (庫内側)	P32P11F		2	2	2	
C3		1656019	Center stay	中央ステー	3P167260-1		1	1		
C3		1686584	Center stay	中央ステー (裏板SUS 0.8t仕様)	3P164565-1				1	
C4		1679315	Side stay	サイドステー (1) 裏板SUS仕様	3P168538-1		1	1		
C4		1686577	Side stay	サイドステー (1) (裏板SUS t0.8仕様)	3P164449-1				1	
C5		1679409	Side stay(2)	サイドステー (2) 裏板SUS仕様	3P172409-1		1	1		
C5		1701159	Side stay(2)	サイドステー (2) (裏板SUS t0.8仕様)	3P164450-1				1	
C6		1667141	Rear stay	背面ステー (裏板SUS仕様)	3P167261-2		4	4		
C6		1686591	Rear stay	背面ステー (型材・裏板SUS t0.8仕様)	3P165208-1				4	
C7		1666838	Casing frame, evaporator	蒸発器枠 (1) 裏板SUS仕様	2P170293-1		1	1		
C7		1700930	Casing frame, evaporator	蒸発器枠 (1) ファンカバーSUS t0.8仕様	2P164446-1				1	
C8		1666845	Casing frame, evaporator	蒸発器枠 (2) 裏板SUS仕様	2P170293-2		1	1		
C8		1700947	Casing frame, evaporator	蒸発器枠 (2) ファンカバー t0.8SUS仕様	2P164446-2				1	
C9		1667165	Fan guide fixing plate	ファンガイド固定板(裏板SUS仕様)	3P168540-1		1	1		
C9		1726569	Fan guide fixing plate	ファンガイド固定板(ファンカバーSUS t0.8仕様)	3P165414-1				1	
C12		1667088	Fan guide ass'y	ファンガイド組立品(レヒート・樹脂製サームスタ)	3P166890-3		1	1	1	
C13		1667172	Set plate, fan motor	電動機取付脚	3P171676-1		4	4	4	
C14-1		1622434	Rear plate(lower/left)	裏板 (下/左)	2P144516-1		1	1		
C14-2		1622441	Rear plate(lower/right)	裏板 (下/右)	2P144517-1		1	1		
C14-3		1686197	Rear plate(lower)	裏板 (下) (裏板SUS t0.8仕様)	2P163839-2				1	
C15		1496990	Shield plate	遮蔽板	4P123922-1		1	1	1	
C16		1622458	Supply sensor inspection door	サプライセンサ点検蓋	4P148634-1		1	1		
C16		1686926	Supply sensor inspection door	サプライセンサ点検蓋 (裏板SUS t0.8仕様)	4P166062-1				1	
C17-1		1622465	Rear plate(middle)	裏板 (中)	2P144515-1		1	1		
C17-2		1622472	Rear plate(upper)	裏板 (上)	2P144514-1		1	1		
C17-2		1686205	Rear plate(upper)	裏板 (上) (裏板SUS t0.8仕様)	2P163840-2				1	
C18		1266485	Partition plate(drain outlet)	仕切板 (ドレン出口)	4P011317-1		1	1	1	
C19		1135978	Reinforce plate, fan motor	補強板 (ファン電動機台)	4P011316-1		4	4	4	
C21		1135125	Hinge	蝶番	3P043374-1		1	1	1	
C22		1266524	Support plate	支柱補強柱	4P061342-1		1	1		
C23		1605466	Mounting plate	サプライセンサ取付板	4P144433-1		1	1	1	
C24	A	1713330	Sensor(SS)	センサー (SS)	3PA61769-16		1	1	1	Refer to Page62
C25	A	1713347	Sensor(DSS)	センサー (DSS)	3PA61769-17		1	1	1	Refer to Page62
C26	A	1713354	Sensor(RS)	センサー (RS)	3PA61769-18		1	1	1	Refer to Page62
C27	A	1713361	Sensor(DRS)	センサー (DRS)	3PA61769-19		1	1	1	Refer to Page62
C28		860015	Universal nut	自在ナット	R4713188-1		1	1	1	
C29		1685170	Pan head screw	ナベ小ネジM5SUS (±穴付)	4P167690-1		18	18	20	
C30		860005	Washer, speed bolt	スピードボルト用座金	R4713334		2	2	2	

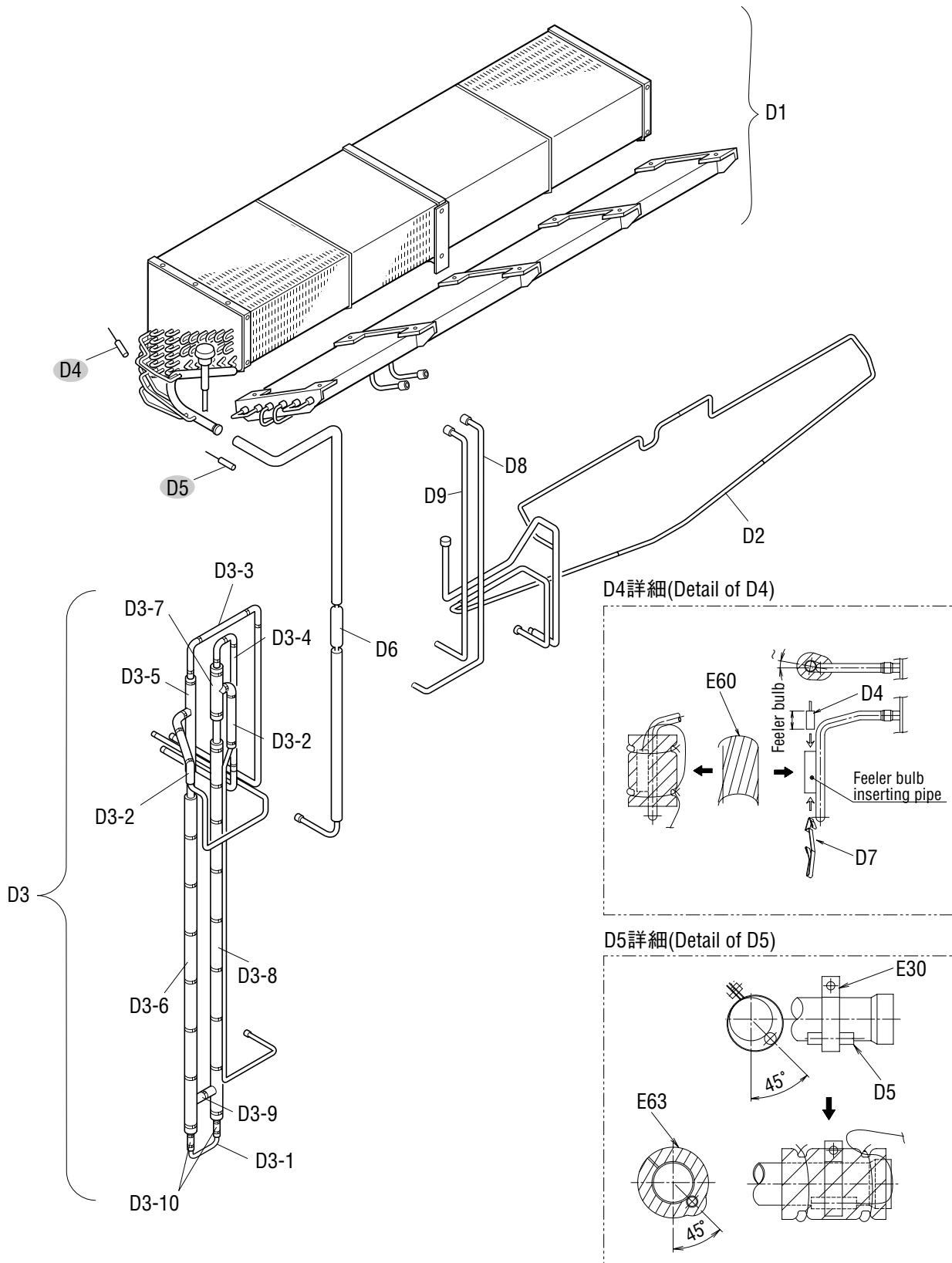

Other parts(Pipe clamp, sealing and insulation material etc.)
 その他部品 (配管固定具、シール材、防熱材等)

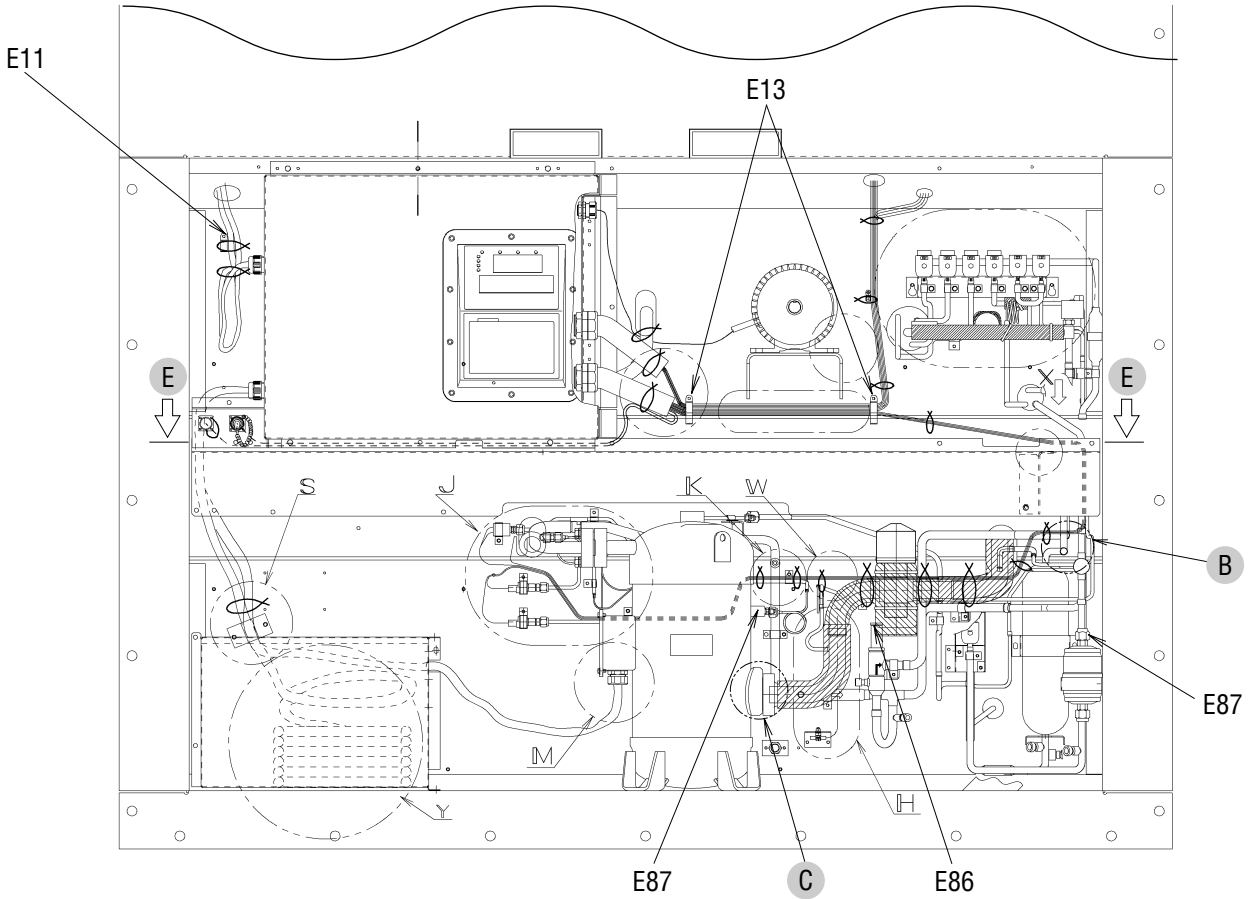

B詳細(Detail of B)

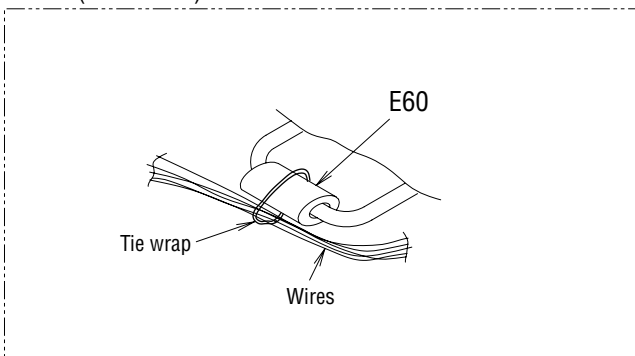

C詳細(Detail of C)

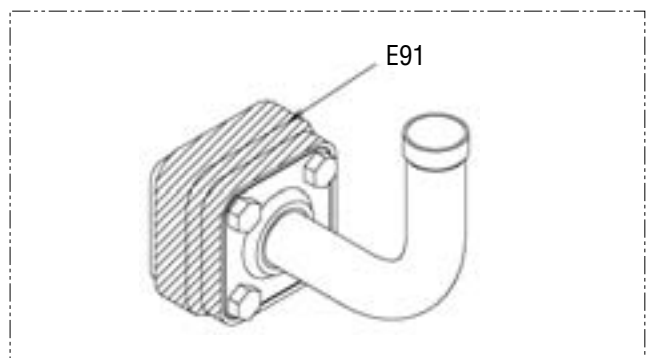

E断面(Section of E)

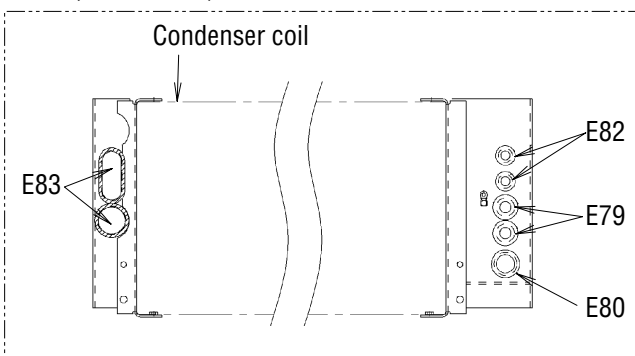

※(L = XX mm) indicates the length of cushion rubber E35.(Cut to suit pipe size.)

※(L = XX mm)と表記のものは、緩衝ゴム(E35)の長さです。(配管のサイズに合わせて切って使用ください。)

矢視A/B(View A/B)

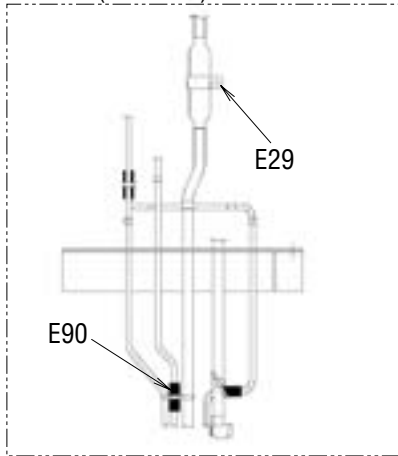

矢視D(View D)

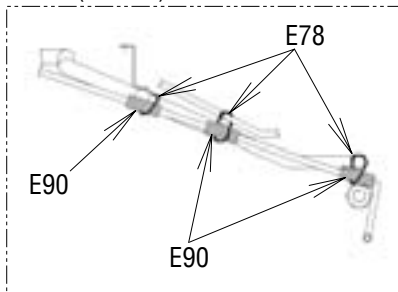

受液機器部詳細
(Receive part detail)

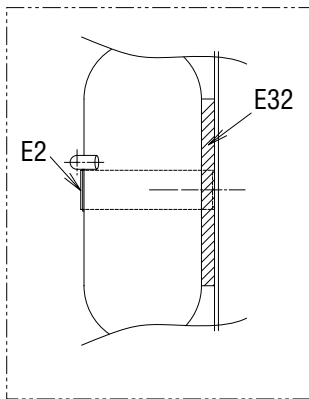

ドライヤー部詳細
(Dryer part detail)

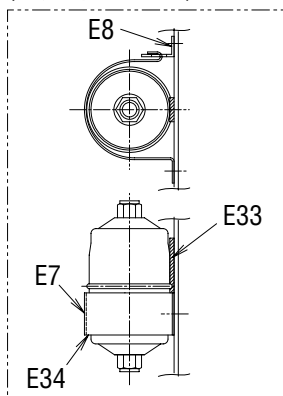

圧力センサー配管部詳細
(Pressure transducer detail)

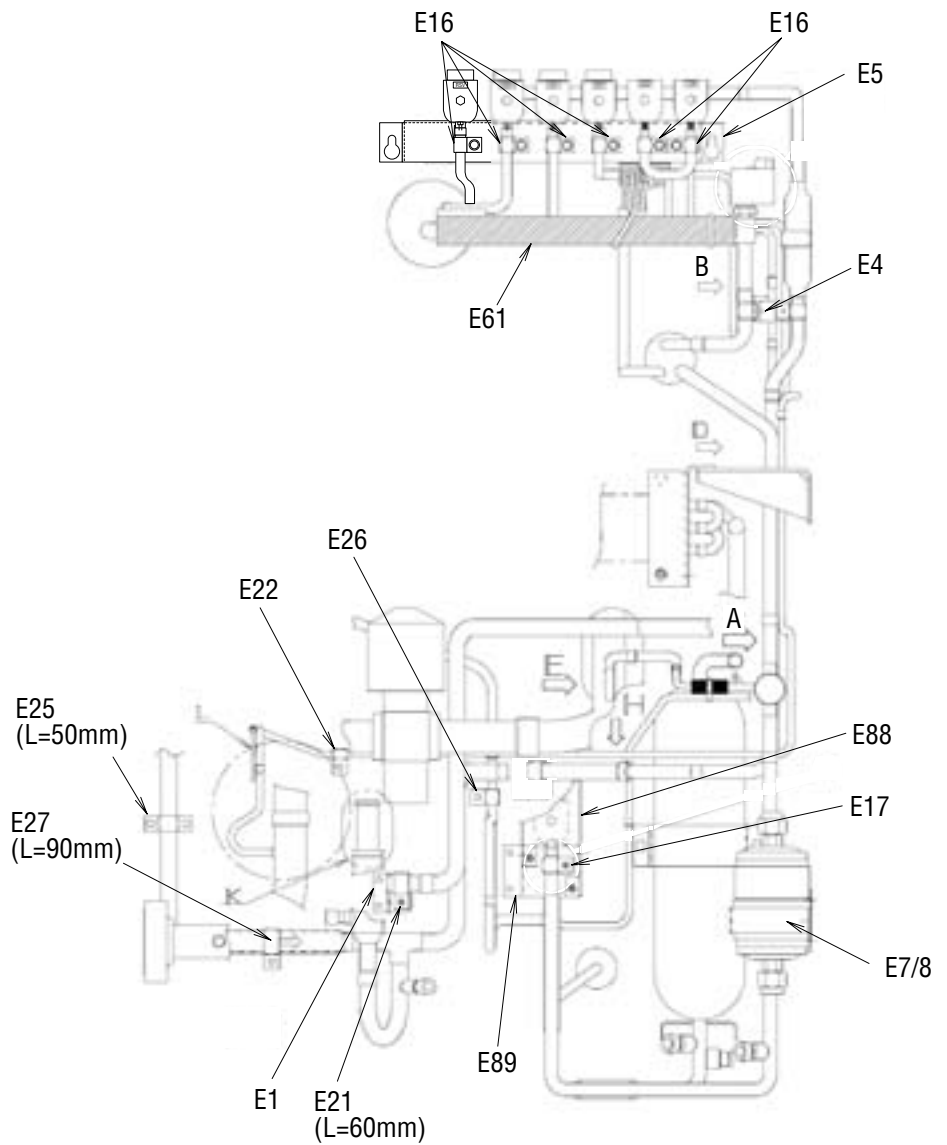
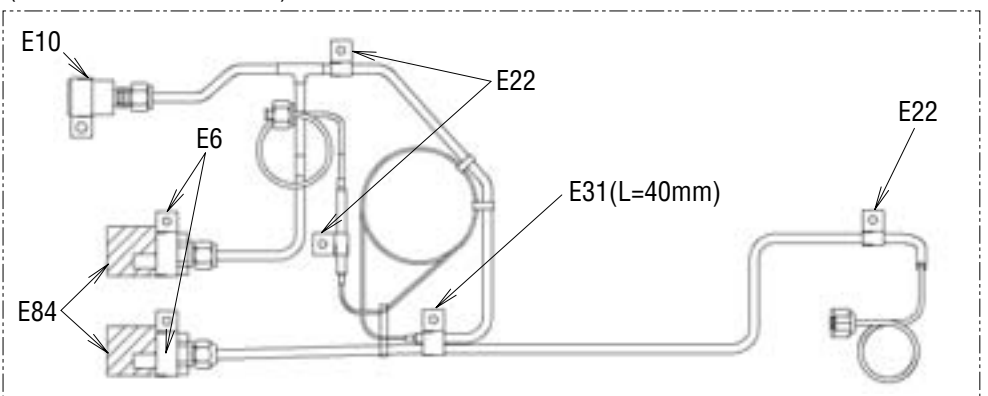

Other parts(Pipe clamp, sealing and insulation material etc.)
その他部品 (配管固定具、シール材、防熱材等)

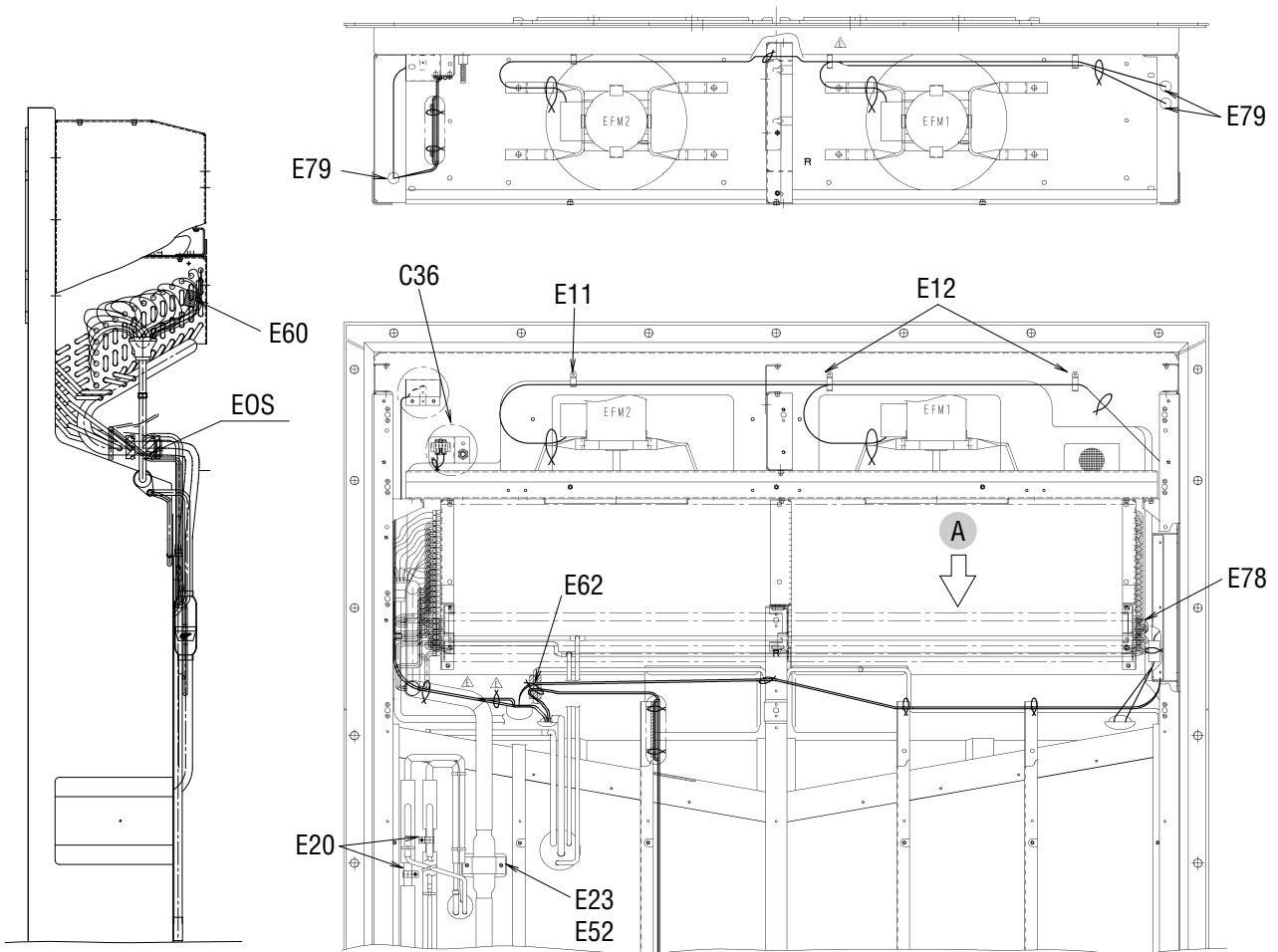

矢視A(VIEW A)

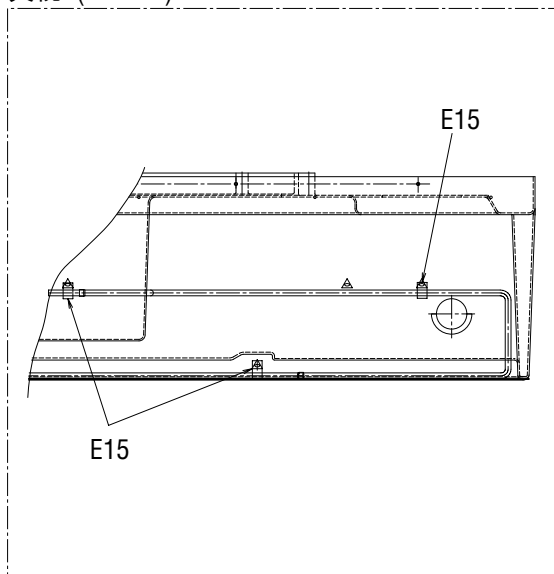

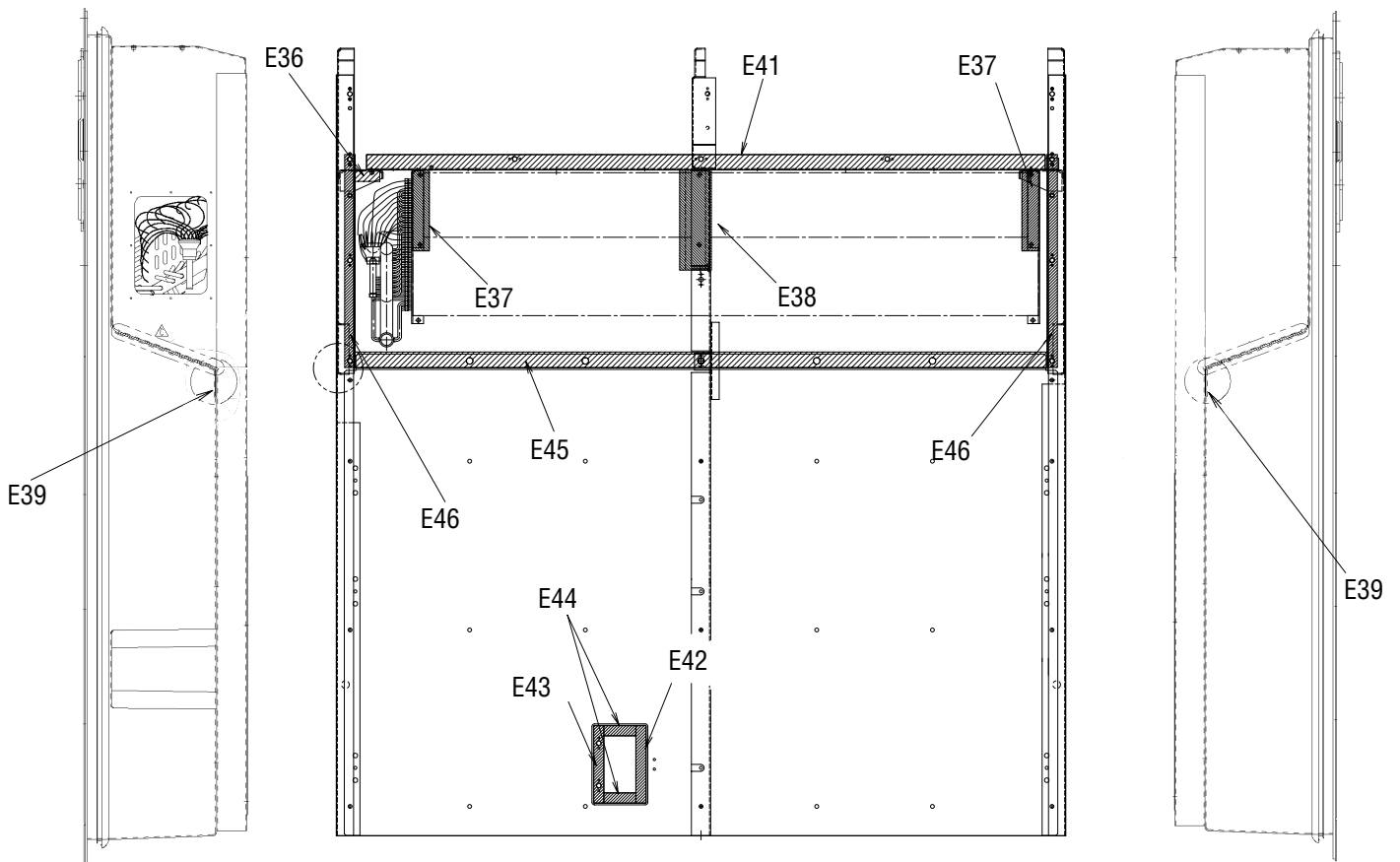
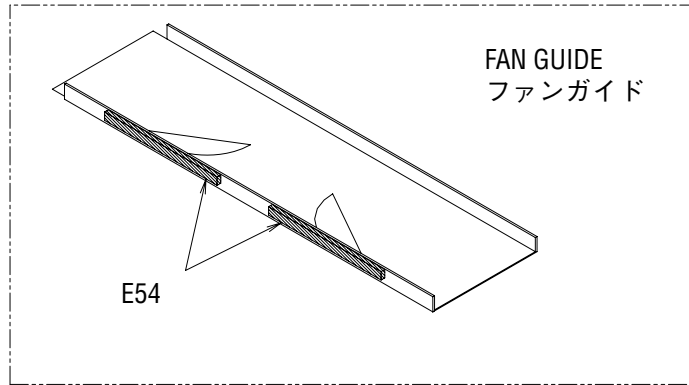

Other parts(Pipe clamp, sealing and insulation material etc.)
その他部品 (配管固定具、シール材、防熱材等)

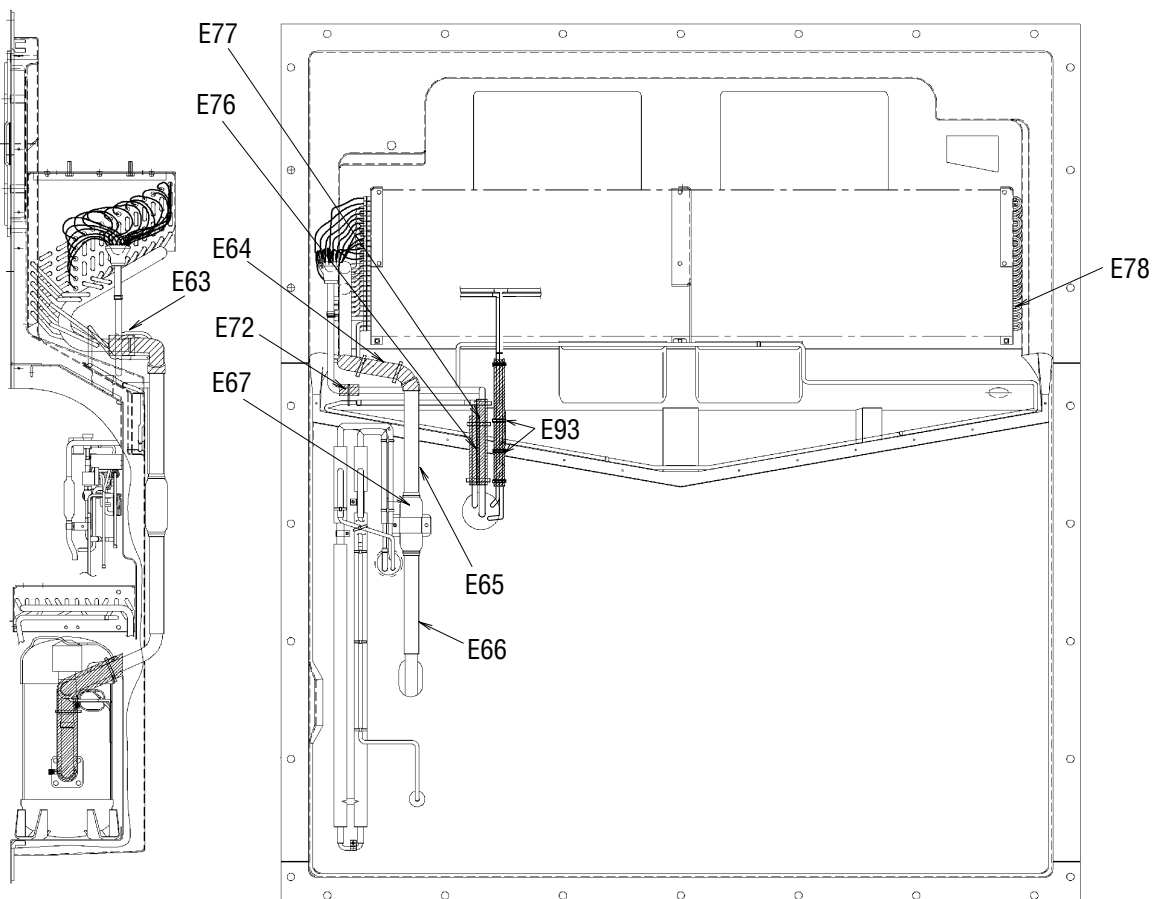
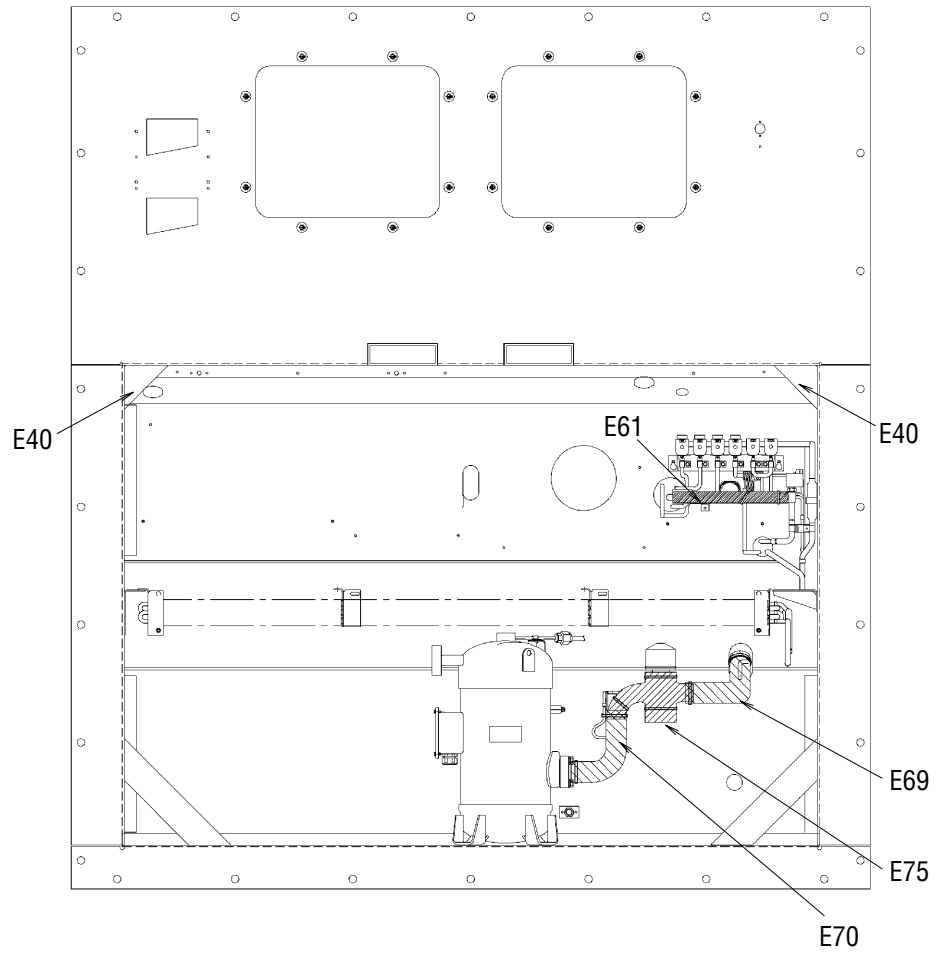

NO. 符号	INDEX	PARTS NO. 部品番号	PARTS NAME	部品名称	DWG. NO. 図面番号	TYPE SPECIFICATION 形式 仕様	QTY/UNIT			REMARKS 備考
							LXE10E-			
							A15F	A15G	A15H	
E1		1266694	Set plate, discharge pipe	吐出配管取付板	4P079462-1		1	1	1	Page33
E2		1266702	Fixture plate, receiver	レシーバー固定具	4P011318-2	t1.5	1	1	1	Page33
E4		1683972	Pipe fixing plate	配管取付板組立品 (MSL)	4P158750-1		1	1	1	Page33
E5		1726608	Mounting plate	電磁弁取付板	4P172423-1		1	1	1	Page33
E6		1592425	Tube clamp	管止め金	NE31016-58		2	3	3	Page33
E7		1266764	Fitting band, dryer	ドライヤー取付バンド	4PA51194-1		1	1	1	Page33
E8		1266771	Set plate, dryer	取付板 (ドライヤ)	4P076788-1	t2.0	1	1	1	Page33
E10		1222764	Resin clamp	樹脂バンド	NE41015-9	MILK WHITE	1	1	1	Page33
E11		0944528	Resin clamp	樹脂バンド	NE41015-7	MILK WHITE	2	2	2	Page32,34
E12		0142492	Resin clamp	樹脂バンド	NE41015-10	MILK WHITE	2	2	2	Page34
E13		1266788	Resin clamp	樹脂バンド	NE41015-12	MILK WHITE	6	6	6	Page32
E14		0508162	Resin clamp	樹脂バンド	NE41015-3		1	1	1	Page26
E15		0782775	Tube clamp	管止め金	NE31016-51		5	13	13	Page34
E16		1584215	Nylon coating tube clamp	ナイロンコーティング管止め金	4P143802-51		6	6	6	Page33
E17		1584208	Nylon coating tube clamp	ナイロンコーティング管止め金	4P143802-52		1	1	1	Page33
E20		1386992	Tube clamp, double tube heat exch	二重管熱交換管止め金	4P103281-56		2	2	2	Page34
E21		0016290	Tube clamp	管止め金	NE31016-56		1	1	1	Page33
E22		1584239	Nylon coating tube holder	ナイロンコーティング管止め金	4P143802-71		4	4	4	Page33
E23		1266827	Fixing plate, filter	フィルタ固定具	4P071794-1	t1.5	1	1	1	Page34
E24		1386985	Tube clamp, double tube heat exch	二重管熱交換管止め金	4P103281-51		1	1	1	
E25		1266841	Tube clamp	管止め金 (2)	4P005817-2		1	1	1	Page33
E26		1584215	Nylon coating tube clamp	ナイロンコーティング管止め金	4P143802-51		2	2	2	Page33
E27		1266858	Tube clamp	管止め金	NE31016-59		1	1	1	Page33
E29		1584246	Nylon coating tube clamp	ナイロンコーティング管止め金	4P143802-59		1	1	1	Page33
E30		537320	Hose band	ホースバンド	R4716528-3		2	2	2	Page30
E31		1380970	Hot gas tube clamp	ホットガス管止め金	4PA43040-1		1	1	1	Page33
E32		1266889	Cushion rubber, pipe clamp	緩衝ゴム (管止用)	4P064896-1	t1.0	1	1	1	Page33
E33		1266896	Seal packing	シールパッキン	4P011314-1		1	1	1	Page33
E34		1270446	Dryer cushion rubber	ドライヤ緩衝ゴム	4PA53083-2		1	1	1	Page33
E35		1584253	Cushion rubber	緩衝ゴム	NE41013-3-300		1	1	1	
E36		1386947	Sealing material, evaporator frame	蒸発器受枠 (1) シール材	4P090149-1		1	1	1	Page35
E37		1266935	Packing(for evaporator)	パッキン (蒸発器)	4P063465-1		2	2	2	Page35
E38		1266942	Packing(for evaporator)	パッキン (蒸発器)	4P063465-2		1	1	1	Page35
E39		1381036	Packing	パッキン	4P095033-1		2	2	2	Page35
E41		1386954	Packing, fan guide	ファンガイドパッキン	3P090183-1		1	1	1	Page35
E42		1266973	Sealing material(patch plate2)	シール材 (当板2)	4P068964-1	t5.0	1	1		Page35
E43		1381043	Sealing material(patch plate3)	シール材 (当板3)	4P095038-1		1	1		Page35
E44		1266997	Sealing material(patch plate1)	シール材 (当板1)	4P068968-1	t5.0	2	2		Page35
E45		1267008	Sealing packing	シールパッキン	3P011293-1		1	1	1	Page35
E46		1267015	Packing(side stay)	パッキン (サイドステー)	4P074127-1	BLACK	2	2		Page35

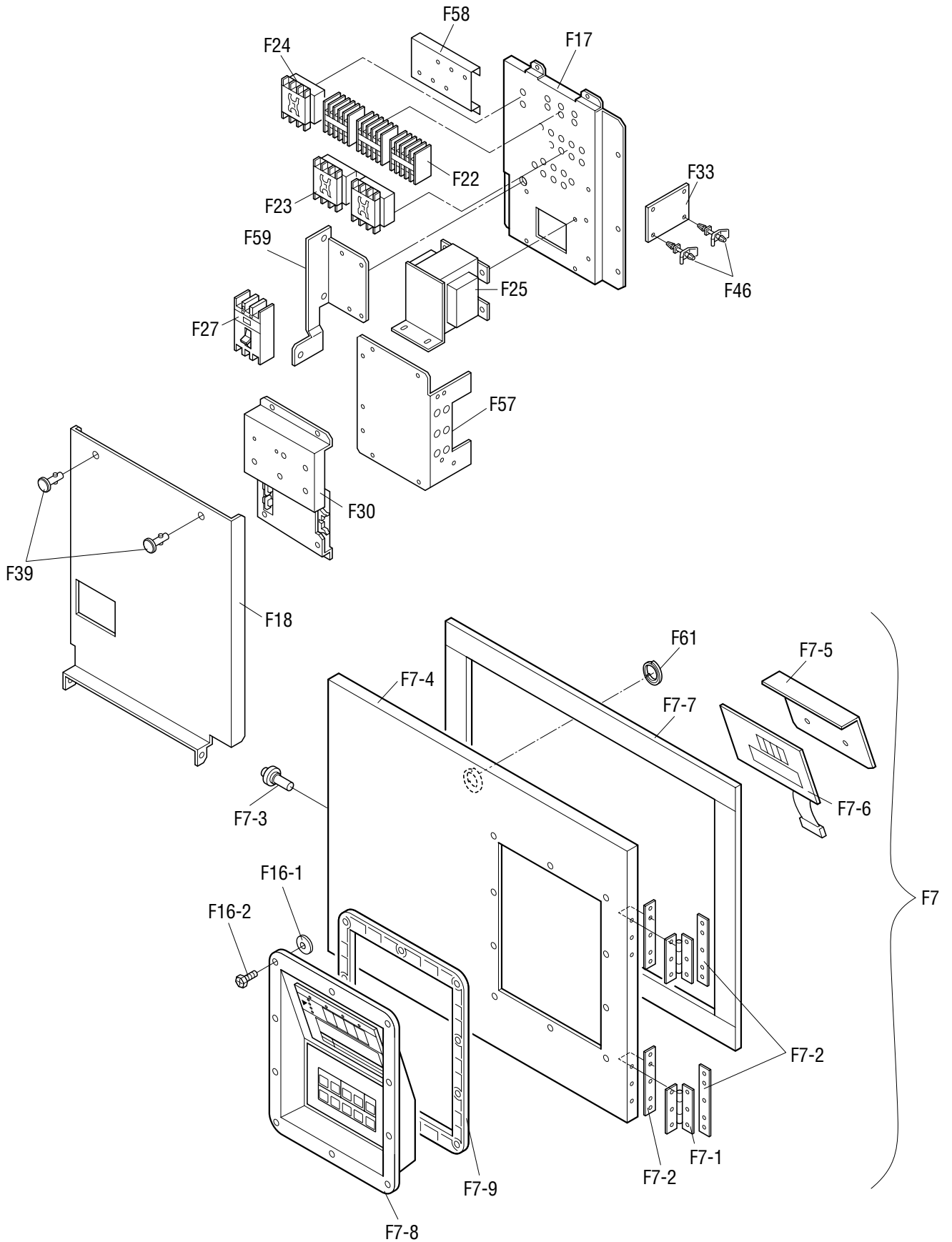

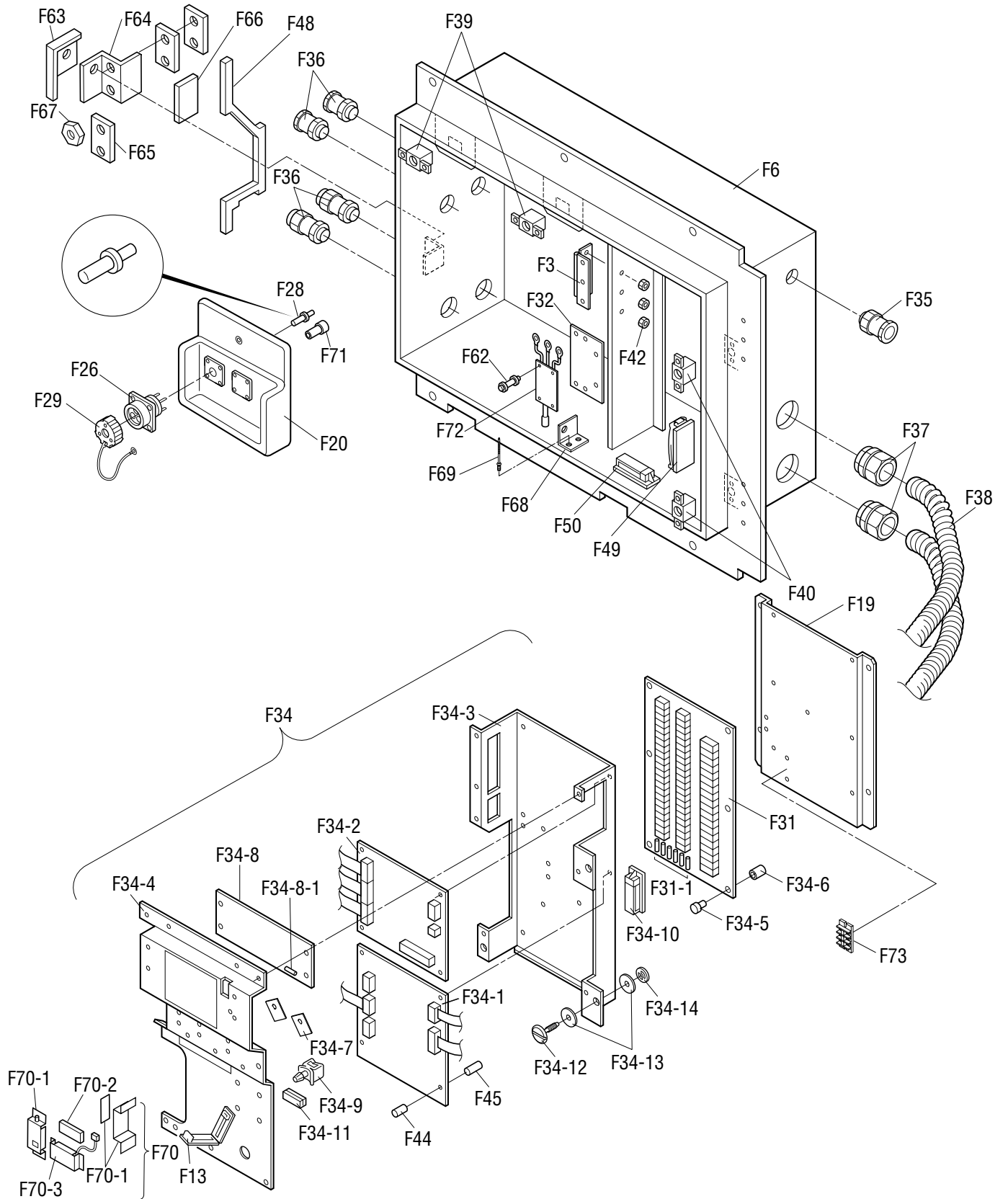

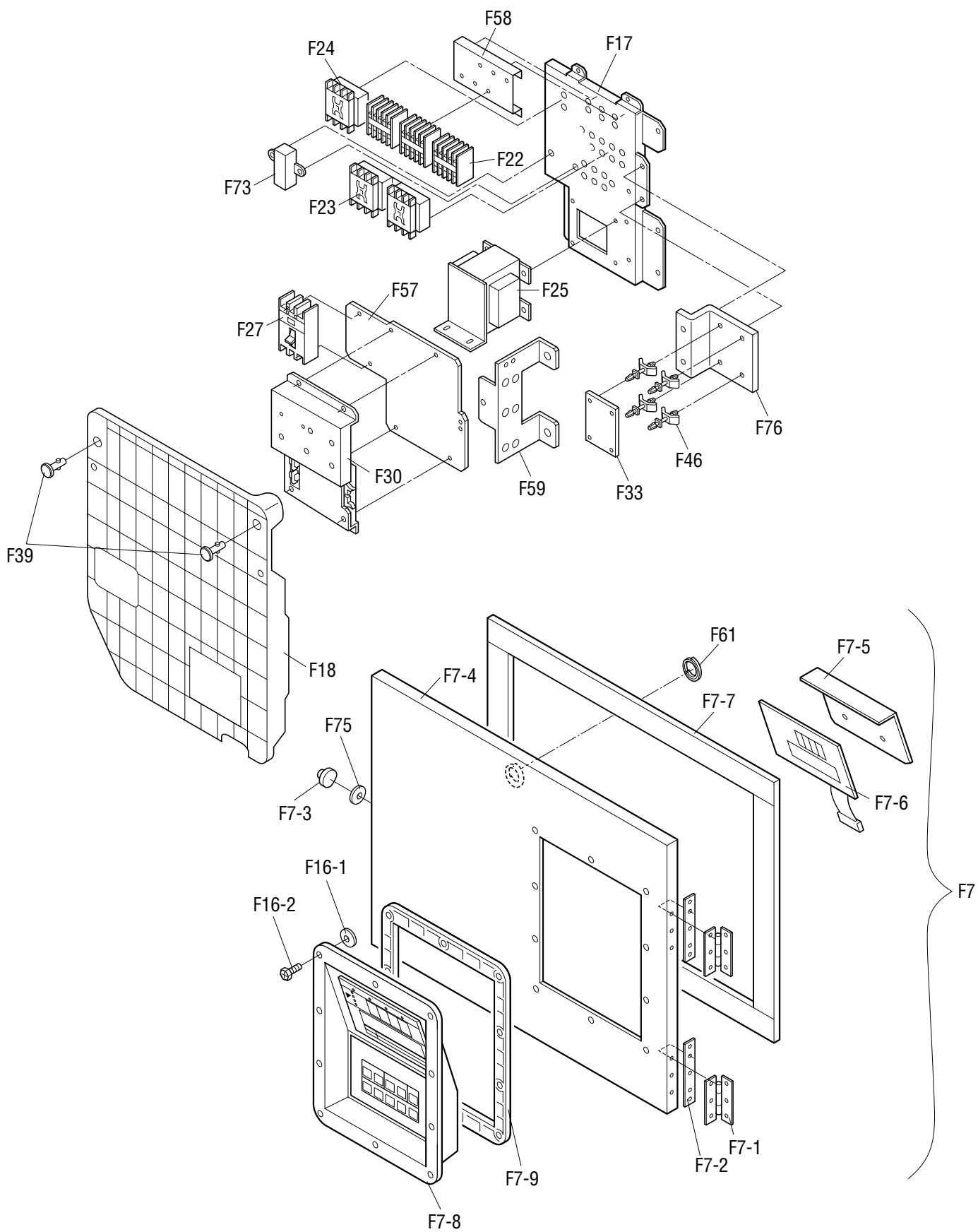

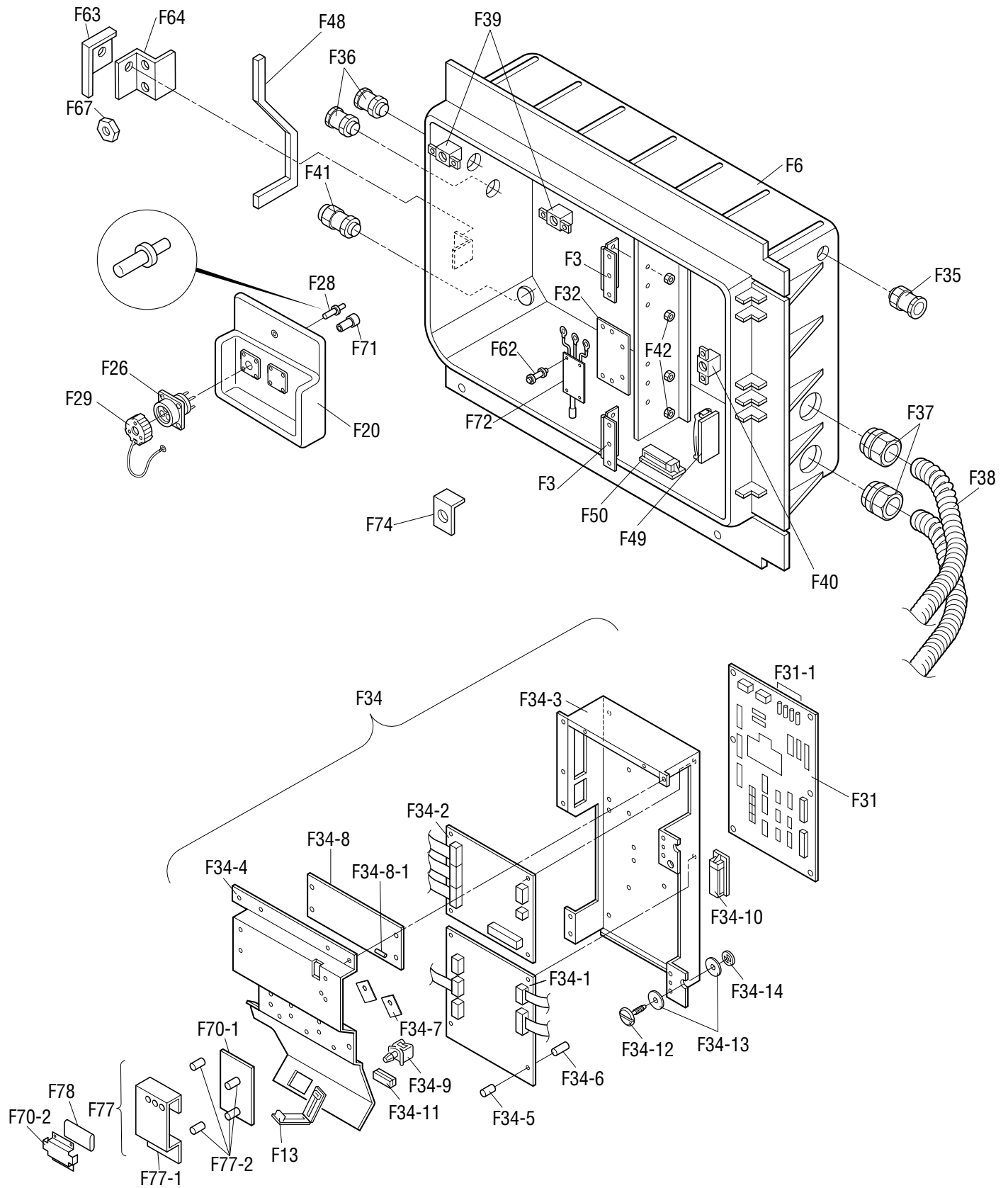

NO. 符号	INDEX	PARTS NO. 部品番号	PARTS NAME	部品名称	DWG. NO. 図面番号	TYPE SPECIFICATION 形式仕様	QTY/UNIT			REMARKS 備考
							LXE10E-			
							A15F	A15G	A15H	
F3	C	1136407	Hinge(recorder/box cover)	平蝶番 (レコーダボックス蓋)	4P021346-1		2	2	2	
F6		1622496	C.BOX welding ass'y	コントロールボックス溶接組立品	2P098553-4		1			
F6		1796289	C.BOX welding ass'y	コントロールボックス組立品(樹脂)	2P197567-1			1	1	
F7	C	1600636	Control box cover ass'y	コントロールボックス蓋組立品	2P147871-6		1			Refer to Page58
F7		1739301	Control box cover ass'y	コントロールボックス蓋組立品	2P171706-6			1	1	Refer to Page58
F7-1	C	1136407	Hinge(recorder/box cover)	平蝶番 (レコーダボックス蓋)	4P021346-1		2	2	2	
F7-2		1136414	Patch plate nut	当板ナット	4P044898-2		4	2	2	
F7-3		0907093	Roller, quick lock lever	ワンタッチ金具用ローラ	4PA51277-1		1			
F7-3		1267875	Roller	ワンタッチ金具用ローラ	3P054321-1			1	1	
F7-4		1587841	Control box cover welding ass'y	コントロールボックス蓋溶接組立品	3P085038-5		1			
F7-4		1739318	Control box cover welding ass'y	コントロールボックス蓋溶接組立品	3P172570-1			1	1	
F7-5		1267457	Operation display cover	操作表示カバー	3P078251-1	t1.0	1			
F7-5		1099731	Operation display cover	操作表示カバー	2P028273-1			1	1	
F7-6	A	1010815	Display board	表示基板	2P010368-2		1	1	1	
F7-7		1381081	Packing for control box cover	パッキン(コントロールボックス蓋)	4P085198-1		1			
F7-7		1497188	Rubber gasket	パッキン(コントロールボックス蓋)	4P111693-1			1	1	
F7-8	A	1295553	Control panel(with sheet key)	コントロールパネル(シートキー付)	3P085319-1		1	1	1	
F7-9		1128949	Packing	パッキン (樹脂パネル)	3P030317-1		1	1	1	
F13		1136539	Clamp	クランプ金具	4P015574-2		1	1	1	
F16-1		0907062	Seal washer	シール座金 (ボンテッド座金)	4PA21941-5		10	10	10	
F16-2		1267488	Pan head machine screw	アブセット小ネジ	4P067677-1	M5×16	10	10	10	
F17		1387197	Set plate(1)	機器取付板 (1)	2P095432-1		1			
F17		1739325	Set plate(1)	機器取付板 (1)	2P165714-1			1	1	
F18		1267503	Blind plate(2)	機器取付板 (2)	2P078296-1	t1.2	1			
F18		1739332	Blind plate(2)	機器取付板 (2)	1P173093-1			1	1	
F19		1549870	Mounting plate	端子台基板取付板	3P092019-1		1			
F20		1630916	PC port fixing plate	樹脂製パソコンポート固定具(PPR5・無)	2P154325-4		1	1	1	
F22	A	119893J	Magnetic contactor(for Fans)	電磁接触器 (ファン用)	3P055568-1	24V PAK-6J31C	3	3	3	
F23	A	124149J	Magnetic contactor(Phase correction contactor)	相順切換電磁接触器 (PCC)	3P071508-3	24V RSK-35J	1	1	1	
F24	A	119891J	Magnetic contactor(Compressor)	電磁接触器 (圧縮機)	3P055566-1	24V PAK35J-S536	1	1	1	
F25	C	1562796	Low frequency transformer	低周波変圧器	3P139293-1		1	1	1	
F26	C	1381113	PC port connector	パソコンポートコネクタ	3P073218-1		1	1	1	
F27	A	1381120	Earth leakage circuit breaker	漏電遮断器	3P093326-1		1	1	1	
F28	C	1141144	Contactore, receptacle	コンタクタ	3P010806-1	HD10	3	3	3	
F29		1381137	PC port connector ass'y	パソコンポートカバー組立品	3P010743-2		1	1	1	
F30	A	0954633	PT/CT board	P T / C T ボード	2P010906-3		1	1	1	
F31	A	1679137	Terminal strip boaed	端子台基板	2P174377-1		1	1	1	
F31-1	A	003065J	Fuse, controller	制御用ヒューズ	4SA42006-4	250V 10A	6	6	6	
F32		1381144	Mounting plate thermal sensor	温度センサ取付板	4P010921-1		1			
F32		1739349	Mounting plate humidity sensor	湿度センサ取付板	4P168053-1			1	1	

NO. 符号	INDEX	PARTS NO. 部品番号	PARTS NAME	部品名称	DWG. NO. 図面番号	TYPE SPECIFICATION 形式仕様	QTY/UNIT			REMARKS 備考
							LXE10E-			
							A15F	A15G	A15H	
F33	A	1787230	Reverse phase protector	逆相保護装置 (R P P)	3P198363-1	346-440V	1	1	1	
F34		1645747	Controller assemblies	コントローラ組立品	3P161732-2		1			
F34		1775477	Controller assemblies	コントローラ組立品	3P172236-7			1	1	
F34-1	A	1642553	PCB ass'y	プリント基板組立品	2P161091-2		1	1	1	
F34-2	A	0954594	I/O board ass'y	I/O ボード	2P010367-1		1			
F34-2	A	1775484	I/O board ass'y	I/O ボード	2P010367-3			1	1	
F34-3		1381151	Bottom plate(sheet metal)	コントローラ底板	2P098577-1		1			
F34-3		1739363	Bottom plate(sheet metal)	コントローラ底板	2P168028-1			1	1	
F34-4	B	1381168	Controller cover	蓋 (コントローラ)	2P099967-1		1			
F34-4	B	1739370	Controller cover	蓋 (コントローラ)	2P168029-1			1	1	
F34-5		1099940	Support bushing, PCB	プリント基板サポートブッシュ	MI49531-11		14	14	14	
F34-6		1099957	Support color, PCB	プリント基板サポートカラー	MI49531-13		14	14	14	
F34-7		1267572	Rubber transistor	放熱用ゴムトランジスタ	4P005330-1		2	2	2	
F34-8	A	1250783	PC board for suction modulating valve	プリント基板組立品(吸入制御弁用)	3P065441-1	EC0058	1	1	1	
F34-8-1	A	044543J	Fuse, control	制御用ヒューズ	4SA42006-3	250V 5A	1	1	1	
F34-9		1267596	Locking wire saddle	ロッキングワイヤサドル	4P015570-2	LWS	3	3	3	
F34-10		1267604	Flat cable clamp	フラットケーブルクランプスナップタイプ	4P015573-1		1	1	1	
F34-12		1267611	Speed bolt	スピードボルト (M6)	4P048680-3	M6X20(S)	2	1	1	
F34-13		860005	Washer, speed bolt	スピードボルト用座金	R4713334		4	2	2	
F34-14		840002	Drop out prevention washer	脱落防止座金	R4718607-6		2	1	1	
F35		1267628	Wire(wire ground)	電線 (電線グラウンド)	4P067662-1		1	1	1	
F36		1267635	Wire(wire ground)	電線 (電線グラウンド)	4P067663-1		4	2	2	
F37		1635346	Wire ground, flexible tube	樹脂製フレキシブル管用グラウンド	4P157387-1		2	2	2	
F38		1635353	Flexible tube(resin)	樹脂製フレキシブル管	4P157410-1		2	2	2	
F39		1267666	Quick fastener	クイックファスナー	4P064642-1		2	2	2	
F40		860015	Universal nut	自在ナット	R4713188-1		2	1	1	
F41		1743216	Wire ground,flexible tube	樹脂製フレキシブル管用コネクタ	4P010926-7			1	1	
F42		833302	Nylon nut	ナイロンナット	R4716460-1	M4	4	4	4	
F44		1099940	Support bushing, PCB	プリント基板サポートブッシュ	MI49531-11		8			
F45		1099957	Support color, PCB	プリント基板サポートカラー	MI49531-13		8			
F46		981616	Locking card spacer	ロッキングカードスペーサー	R3428091-3	KGLS-8S	4			
F46		380401	Locking card spacer	ロッキングカードスペーサー	R3428091-2			4	4	
F48		1326820	Packing for control box front plate	パッキン(コントロールボックス前板(左))	4P085513-1		1			
F48		1739387	Packing for control box front plate	パッキン(コントロールボックス前板(左))	4P172580-1			1	1	
F49		1136539	Clamp	クランプ金具	4P015574-2		2	2	2	
F50		1267712	Clamp	クランプ金具	3P049495-1		1	1	1	
F57		1549894	Sset plate(PT/CT board)	機器取付板 (P T / C T ボード)	3P126713-1		1			
F57		1739394	Breaker plate 1	ブレーカ取付板 (1)	3P168052-1			1	1	
F58		1267781	Mounting plate, elect components	電装品取付板	4P064227-1	t=1.2	1			
F58		1739495	Mounting plate, elect components	電装品取付板 (2)	4P064227-2			1	1	

NO. 符号	INDEX	PARTS NO. 部品番号	PARTS NAME	部品名称	DWG. NO. 図面番号	TYPE SPECIFICATION 形式 仕様	QTY/UNIT			REMARKS 備考
							LXE10E-			
							A15F	A15G	A15H	
F59		1549902	Set plate(breaker)	機器取付板 (ブレーカ)	3P126712-1		1			
F59		1739402	Breaker plate 2	ブレーカ取付板 (2)	3P168051-1			1	1	
F61		1295623	Fixtture(instruction ring)	固定具(インストラクションリング)	4P064698-1	Wire diameter	1	1	1	
F62		1381175	Circuit board spacer	サーキットボードスペーサ	4P000347-1		4	4	4	
F63		1295630	Lever	ワンタッチ金具	4P085171-1		1	1	1	
F64		1295647	Fixing plate for lever	ワンタッチ金具取付板	4P085164-1		1	1	1	
F65		0907125	Sealed sheet	絶縁シート (ワンタッチ金具)	4PA52417-1	t0.075±0.01	1			
F66		0907132	Sealed sheet	絶縁シート (ワンタッチ金具)	4PA52417-2	t0.075±0.01	1			
F67		833301	Nylon nut	ナイロンナット	R4716460-3	M6	3	3	3	
F68		1562859	Implent use cover mounting plate	機器カバー取付板	4P095433-1		1			
F69		1378441	Rivet	リベット	4P057425-2		2			
F70-1	A	1684449	Chargeble battery PCB ass'y	充電器P板組立品	2P174898-1		1	1	1	
F70-2		1726646	Mounting plate	リチャージャブルバッテリーホルダー組立品	4P175166-1		1			
F70-2		1733473	Mounting plate	リチャージャブルバッテリーホルダー組立品(2)	4P175166-2			1	1	
F71		1381221	Straight pin	平行ピン(ドイツ製シールピン)	3P040139-1		2	2	2	
F72		1679447	Humidty sensor(HUS)	湿度センサー	3PA61738-2		1			
F72	A	1780284	Humidy sensor(HUS)	湿度センサー	3PA61738-3	RHU-600A-D2		1	1	
F73	A	0954640	Noise filter	ノイズフィルタ	2PA51273-1	ZAC2206-11	1	1	1	
F74		1780291	Protection plate	保護板 (Y O R K 製モデム)	4P176030-1			1	1	
F75		1780309	Bushing	ワンタッチ金具ローラ用ブッシュ	4P171668-2			1	1	
F76		1780316	Mounting plate, RPP	逆相保護装置取付板	4P168038-1			1	1	
F77	A	1733466	Battery charger ass'y	充電・残ボルトメータ組立品	3P171534-3			1	1	
F77-1		1780323	Mounting plate	充電・残ボルトメータ取付板	4P172284-2			1	1	
F77-2		1684463	Spacer	スペーサ	4P171495-1			4	4	
F78		1679430	Battery	電池	3P174899-1			1	1	

NO. 符号	INDEX	PARTS NO. 部品番号	PARTS NAME	部品名称	DWG. NO. 図面番号	TYPE SPECIFICATION 形式 仕様	QTY/UNIT			REMARKS 備考
							LXE10E-			
							A15F	A15G	A15H	

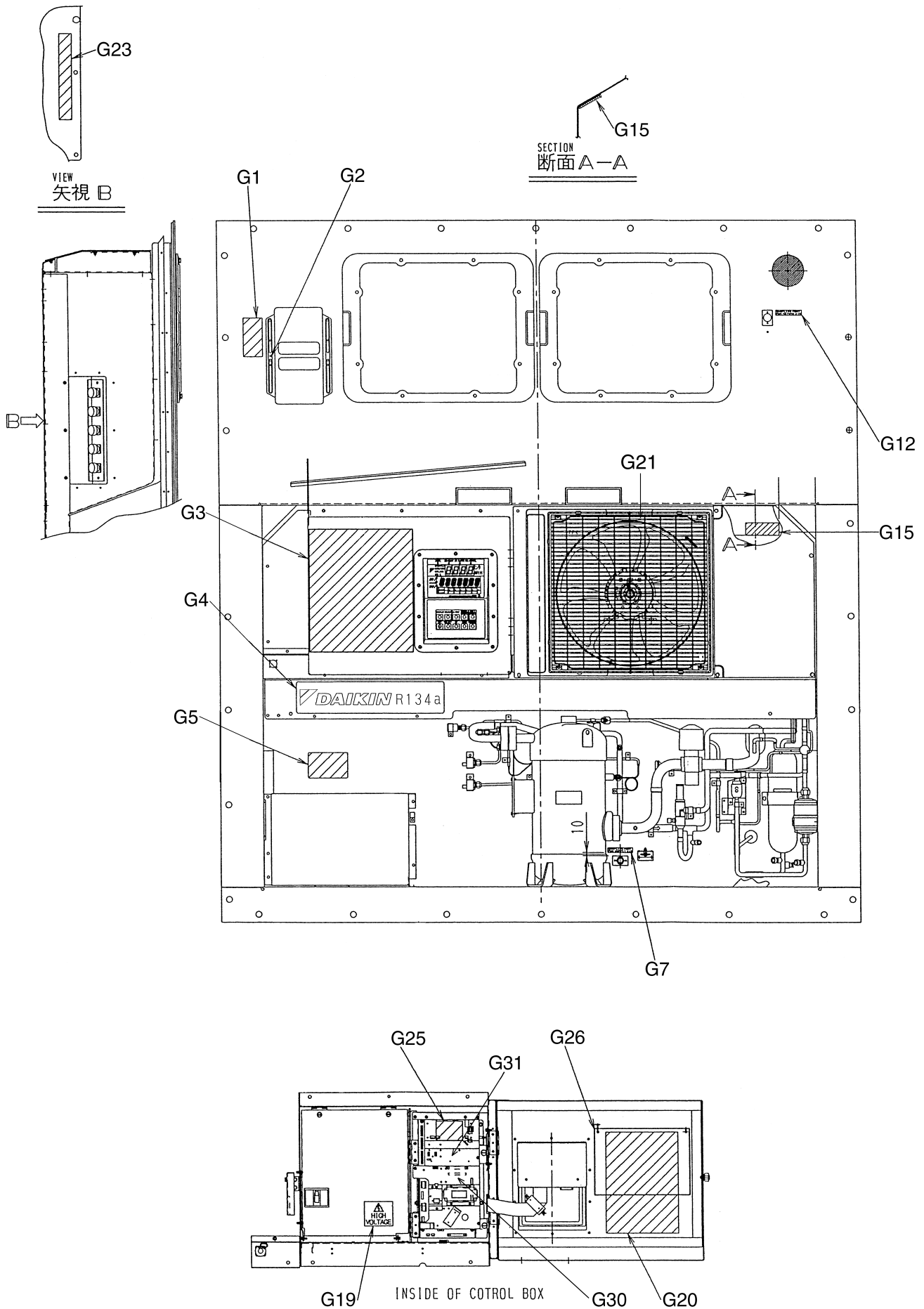

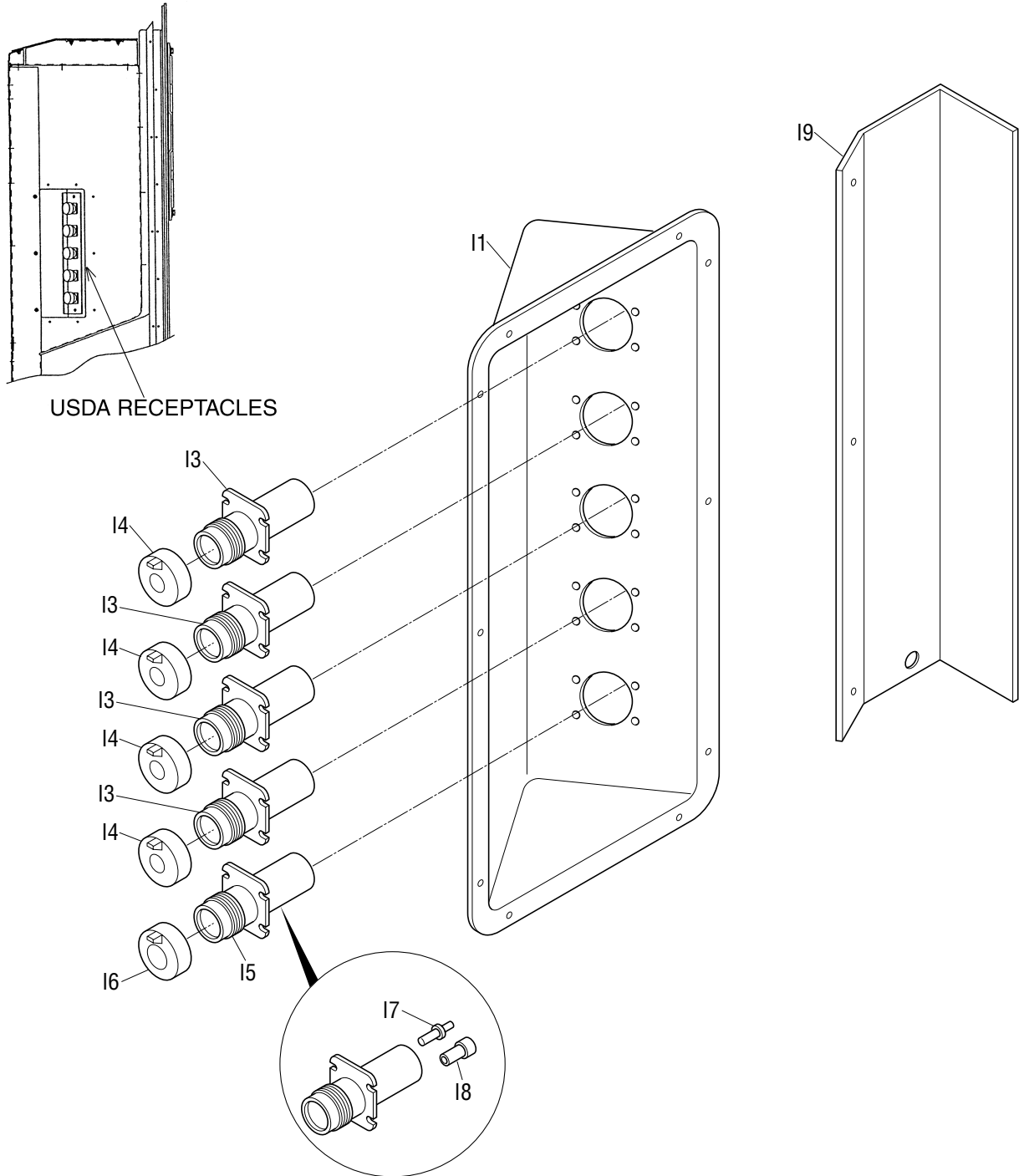

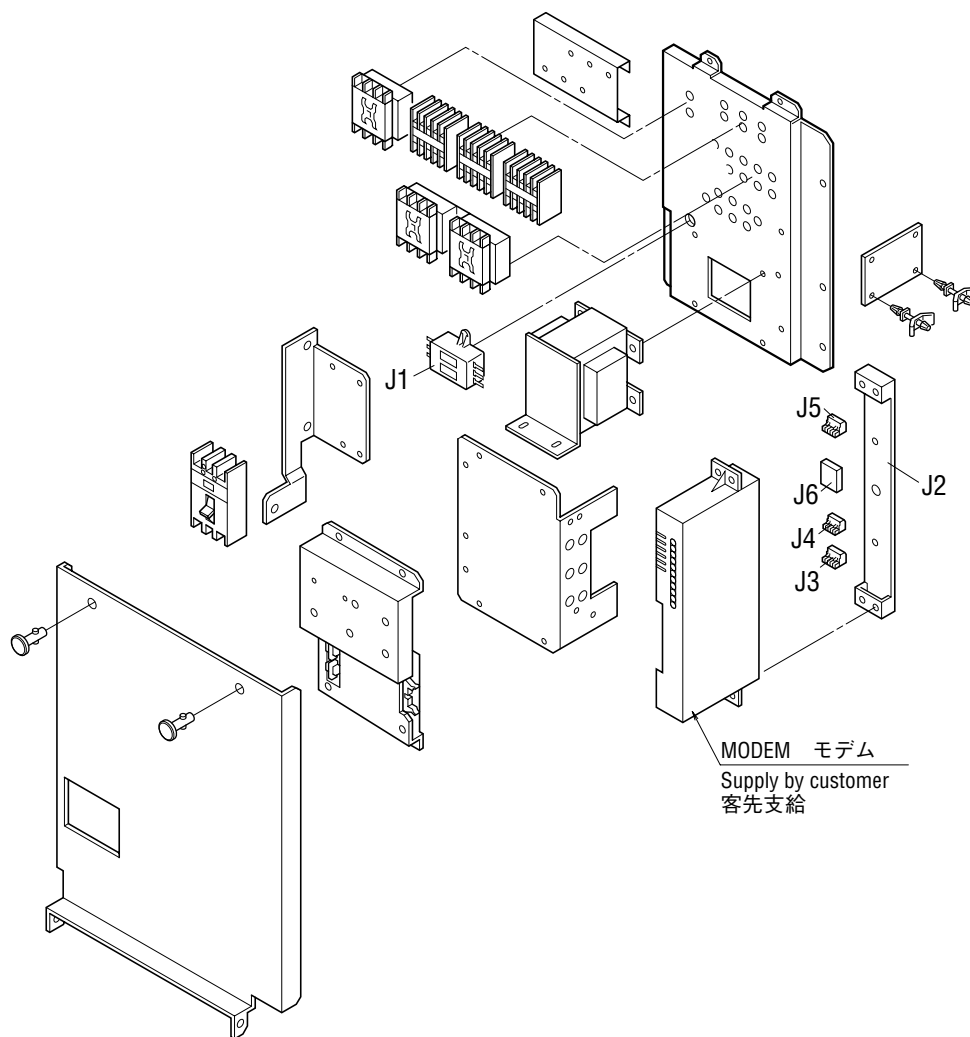

1. Indoor fan guard 1. 庫内ファンガード

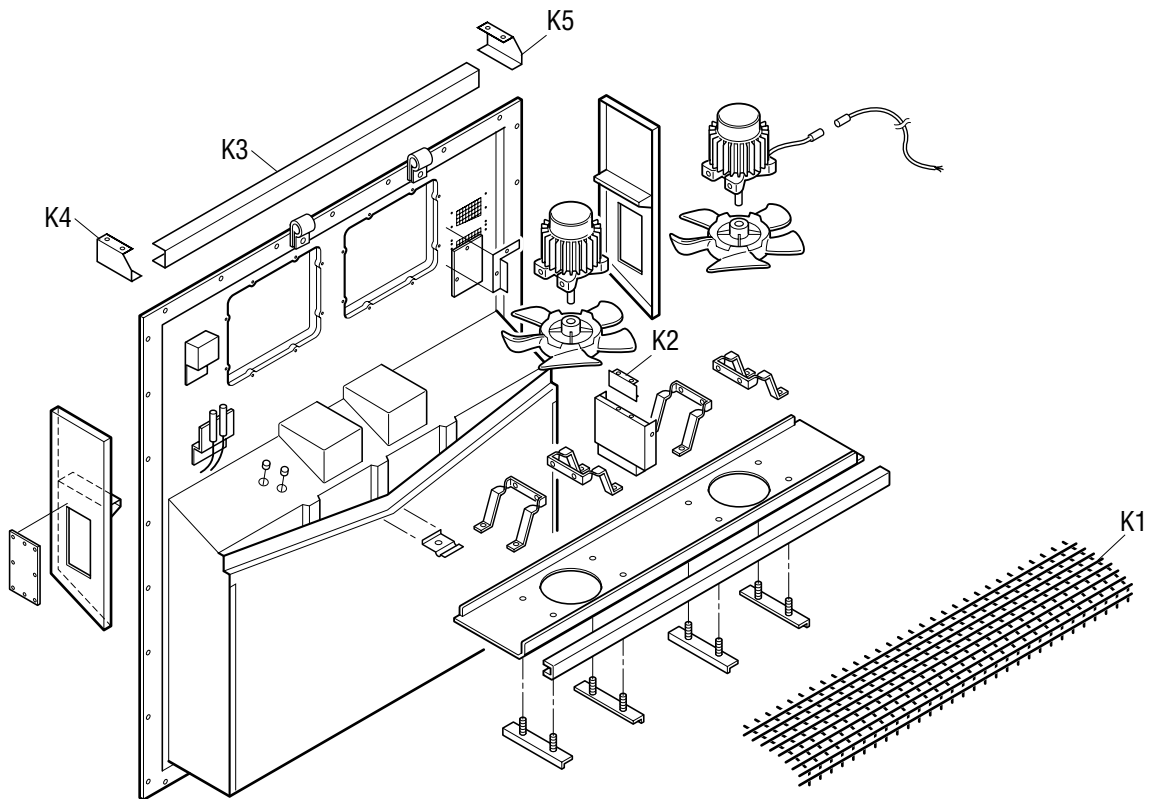

2. Evaporator coil 2. 蒸発器コイル組立品

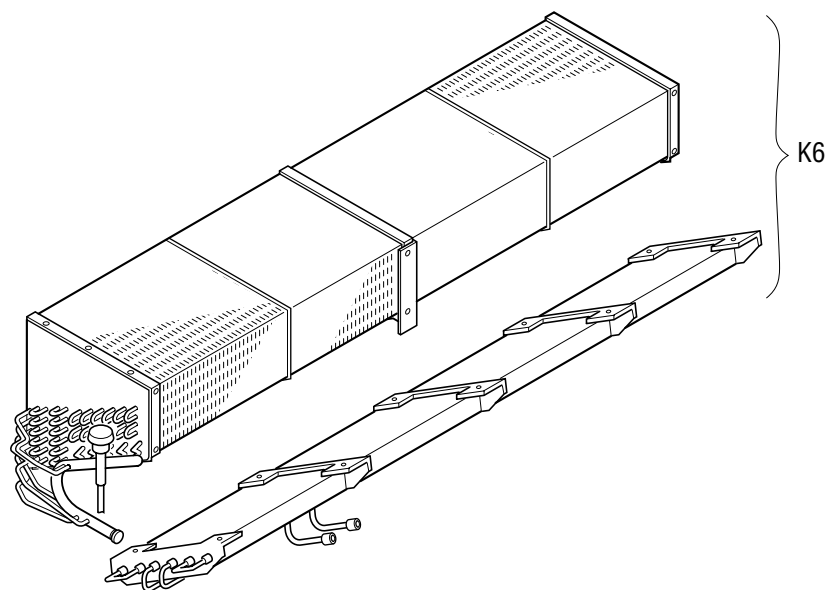

1. Resin clamp

1. 樹脂バンド

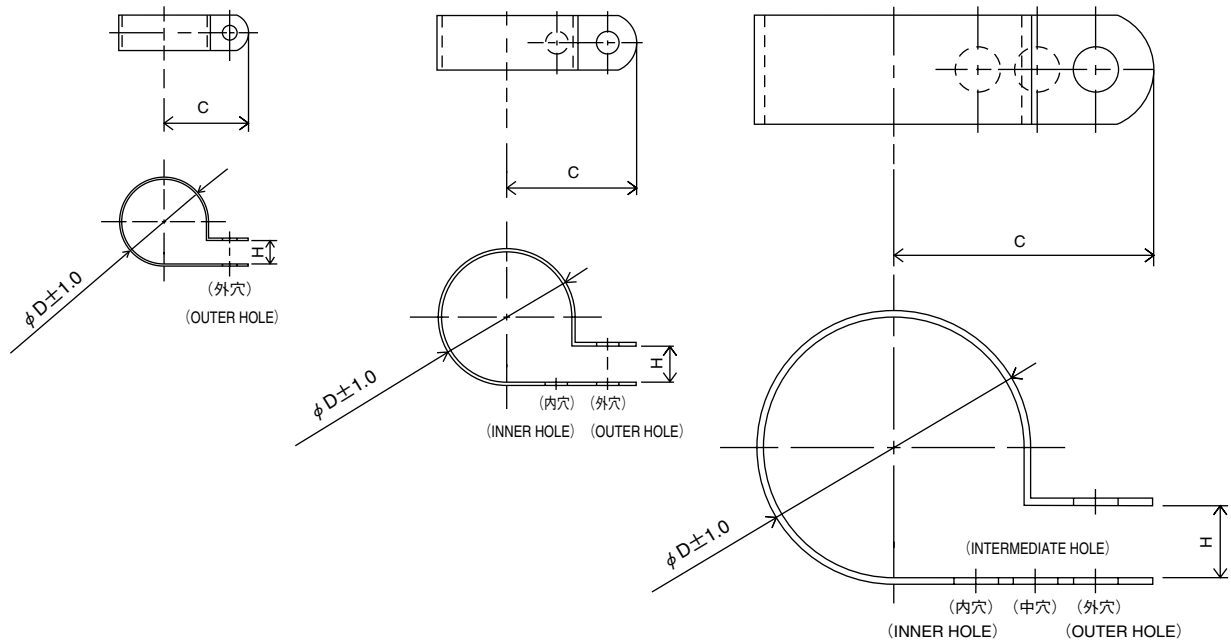

NO. 符号	PARTS NO. 部品番号	PARTS NAME	部品名称	DWG NO. 図面番号	SIZE サイズ			QTY		
					D	C	H	LXE10E-		
								A15F	A15G	A15H
E10	1222764	Resin clamp	樹脂バンド	NE41015-9	26.9	27.8	7.9	1	1	1
E11	0944528	Resin clamp	樹脂バンド	NE41015-7	19.8	24.6	7.9	2	2	2
E12	0142492	Resin clamp	樹脂バンド	NE41015-	29.2	29.4	7.9	2	2	2
E13	1266788	Resin clamp	樹脂バンド	NE41015-	39.4	34.2	9.5	6	6	6
E14	0508162	RESIN CLAMP	樹脂バンド	NE41015-3	8.4	16.7	4.8	1	1	1

2. Tube clamp

2. 管止金

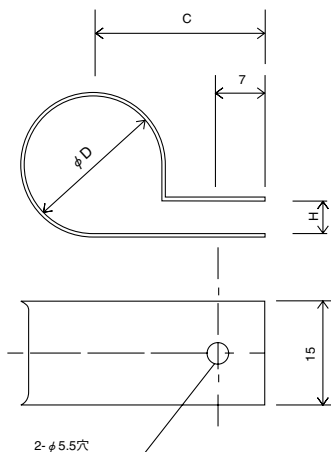

NO. 符号	PARTS NO. 部品番号	PARTS NAME	部品名称	DWG NO. 図面番号	SIZE サイズ			QTY/UNIT		
					D	C	H	LXE10E-		
								A15F	A15G	A15H
E6	1592425	Tube clamp	管止メ金	NE31016-58	24	27	5	2	3	3
E15	0782775	Tube clamp	管止メ金	NE31016-51	10	20	3	5	13	13
E16	1584215	Nylon coating tube clamp	ナイロンコーティング管止メ金	4P143802-51	10	20	3	6	6	6
E17	1584208	Nylon coating tube clamp	ナイロンコーティング管止メ金	4P143802-52	12	21	3	1	1	1
E21	0016290	Tube clamp	管止メ金	NE31016-56	20	25	5	1	1	1
E22	1584239	Nylon coating tube holder	ナイロンコーティング管止メ金	4P143802-71	6.4	20	1	4	4	4
E26	1584215	Nylon coating tube clamp	ナイロンコーティング管止メ金	4P143802-51	10	20	3	2	2	2
E27	1266858	Tube clamp	管止メ金	NE31016-59	26	28	5	1	1	1
E29	1584246	Nylon coating tube clamp	ナイロンコーティング管止メ金	4P143802-59	26	28	5	1	1	1

3. Cushion rubber for pipe clamp

3. 管止金用緩衝ゴム

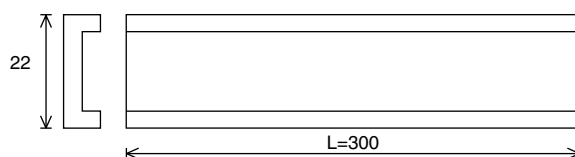

NO. 符号	PARTS NO. 部品番号	PARTS NAME	部品名称	DWG NO. 図面番号	QTY/UNIT			REMARKS 備考
					LXE10E-			
					A15F	A15G	A15H	
E35	1584253	Cushion rubber	管止金用緩衝ゴム	NE41013-3-300	1	1	1	Cut to suit pipe size. 配管サイズに合わせて切って 使用のこと

1. Parts recommended to be ordered together with packing, gasket, sealing material and name plate
1. 発注の際にパッキングやシール材、銘板等の同時発注を推奨する部品

For ordering following spare parts, we recommend that you order the following packing, gasket, sealing material and name plate together at the same time.

上記のサービス扉やボックスカバーを発注の際には、下記のパッキングを同時に発注することをおすすめします。

(1) Service door

(1) サービス扉

NO. 符号	PARTS NO. 部品番号	PARTS NAME	部品名称	DWG NO. 図面番号	QTY/UNIT		
					LXE10E-		
					A15F	A15G	A15H
A4	1612576	Access panel (FRP)	サービス扉組立品	1P006678-5	2	2	2
A5	1266207	Cushion material (access panel)	クッション材 (サービス扉)	3P033608-1	2	2	2
A6	1196113	Sealing material (access panel)	シール材 (サービス扉)	3P001640-2	2	2	2

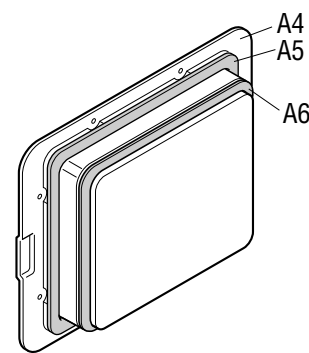

(2) Control box cover

(2) コントロールボックスカバー

NO. 符号	PARTS NO. 部品番号	PARTS NAME	部品名称	DWG NO. 図面番号	QTY/UNIT		
					LXE10E-		
					A15F	A15G	A15H
F7	1600636	C.BOX cover ass'y	コントロールボックス蓋組立品	2P147871-6	1		
F7	1739301	C.BOX cover ass'y	コントロールボックス蓋組立品	2P171706-6		1	1
G3	1557042	Name plate, operation	操作銘板 (C & MODE, 英)	1P136900-1	1	1	1
G20	1739426	Electriv wiring diagram label	電気配線図銘板	2D051874-1	1		
G20	1739433	Electriv wiring diagram label	電気配線図銘板	2D053293-1		1	1

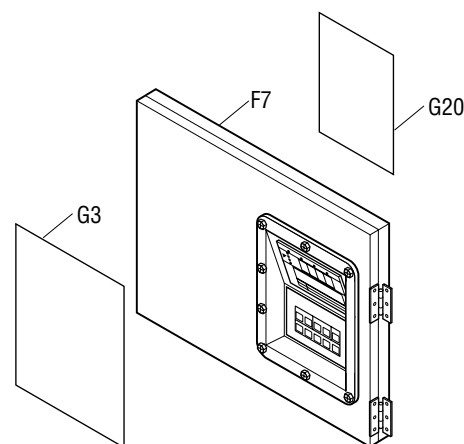

※Rubber gasket, sheet key is attached to control box cover ass'y.

※ゴムガスケットとシートキーはコントロールボックス組立品に付属しています。

(4) Ventilation cover

(4) 換気口蓋

NO. 符号	PARTS NO. 部品番号	PARTS NAME 部品名称		DWG NO. 図面番号	QTY/UNIT		
					LXE10E-		
					A15F	A15G	A15H
A19	0981060	Ventilation cover	換気口蓋	3P003175-1	1	1	1
A20	1266221	Sealing material (access panel)	シール材(換気口)	4P016185-1	2	2	2

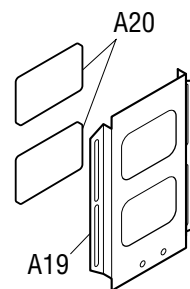

(5) Front plate (CA)

(5) 前板 (CA)

NO. 符号	PARTS NO. 部品番号	PARTS NAME 部品名称		DWG NO. 図面番号	QTY/UNIT		
					LXE10E-		
					A15F	A15G	A15H
A15	1661299	Front plate (CA)	前板 (C A)	2P165976-1	1		
A15	1739286	Front plate (CA)	前板 (C A)	2P173133-1		1	1
G4	1726552	Name plate, Brand name and refrigerant label	意匠銘板 および 冷媒銘板	3P174603-1	1	1	1

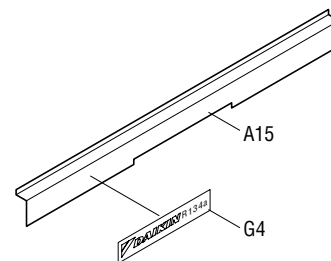

2. Order for motorized valve, solenoid valve and pressure regulating valve

2. 電動弁・電磁弁・圧力調整弁の発注

Refer to the following table for the name, main body, solenoid coil and ass'y of solenoid valves etc. applied to this model.

この機種に使用されている電磁弁等の名称と本体・コイル・組立品は下記のとおりです。

	Body/Coil 本体/コイル	NO. 符号	PARTS NO. 部品番号	PARTS NAME	部品名称	DWG NO. 図面番号	QTY/UNIT			Common Parts 共通部品		
							LXE10E-			NEV-202DXF	VPV-803PQ50	NEV-MOAB507C1
							A15F	A15G	A15H			
1.EV	本体 Body	B7-3	125649J	Electronic expansion valve body	電子膨張弁本体	2SA50010-2-KU	1	1	1			
	コイル Coil	B20	138143J	Electronic expansion valve coil	電子膨張弁コイル	2P010454-2	1	1	1			
2.HSV	本体 Body	B7-4	1787247	Hot gas solenoid valve body	ホットガス電磁弁本体	3P198486-1	1	1	1		○	
	コイル Coil	B7-5	1266290	Hot gas solenoid valve coil	ホットガス電磁弁コイル	3P010453-2	1	1	1			○
3.DSV	本体 Body	B7-4	1787247	Defrost bypass solenoid valve body	デフロストバイパス電磁弁本体	3P198486-1	1	1	1		○	
	コイル Coil	B7-5	1266290	Defrost bypass solenoid valve coil	デフロストバイパス電磁弁コイル	3P010453-2	1	1	1			○
4.BSV	本体 Body	B7-4	1787247	Gas bypass solenoid valve body	ガスバイパス電磁弁本体	3P198486-1	1	1	1		○	
	コイル Coil	B7-5	1266290	Gas bypass solenoid valve coil	ガスバイパス電磁弁コイル	3P010453-2	1	1	1			○
5.RSV	本体 Body	B7-4	1787247	Reheat coil bypass solenoid valve body	レヒートコイルバイパス電磁弁本体	3P198486-1	1	1	1		○	
	コイル Coil	B7-5	1266290	Reheat coil bypass solenoid valve coil	レヒートコイルバイパス電磁弁コイル	3P010453-2	1	1	1			○
6.ESV	本体 Body	B7-6	0088738	Economizer solenoid valve body	エコノマイザ-電磁弁本体	R3305099-1-KI	1	1	1	○		
	コイル Coil	B7-7	1266290	Economizer solenoid valve coil	エコノマイザ-電磁弁コイル	3P010453-2	1	1	1			○
7.ISV	本体 Body	B7-6	0088738	Injection solenoid valve body	インジェクション電磁弁本体	R3305099-1-KI	1	1	1	○		
	コイル Coil	B7-7	1266290	Injection solenoid valve coil	インジェクション電磁弁コイル	3P010453-2	1	1	1			○
8.LSV	本体 Body	B4-5	1787247	Liquid solenoid valve body	液電磁弁本体	3P198486-1	1	1	1		○	
	コイル Coil	B4-6	0955287	Liquid solenoid valve coil	液電磁弁コイル	3P010453-1	1	1	1			○
9.SMV	組立品 Ass'y	B8-1	1254538	Suction modulating Valve	吸入比例弁組立品	2P078385-1	1	1	1		Note1 注1	
10.DPR	組立品 Ass'y	B3-4	1241361	Discharge pressure regulating valve	吐出圧力調整弁	3P074558-1	1	1	1			

Note 1 : Refer Page 22, 23 and 24 for detail parts of suction modulating valve.

注 1 : SMV (吸入比例弁) の詳細部品はP.22、23、24を参照ください。

Note 2 : Difference of solenoid valve No.1266290 and 0955287.

No.1266290 (3P010453-2) : Lead wire length 1550mm (TYPE NEV-MOAB518C1)

No.0955287 (3P010453-1) : Lead wire length 2000mm (TYPE NEV-MOAB507C1)

注 2 : 電磁弁No.1266290とNo.0955287の違い。

No.1266290 (3P010453-2) : リード線長さ1550mm (型式 NEV-MOAB518C1)

No.0955287 (3P010453-1) : リード線長さ2000mm (型式 NEV-MOAB507C1)

3. Order for pressure trasducer

3. 圧力センサーの発注

Refer to the following table for the pressure transducer applied to this model.

For ordering pressure transducer, we recommend that you order the following best shrinkable tube together at the same time.

この機種に使用している圧力センサーは下記の通りです。

圧力センサー発注の際は、下記の熱収縮チューブを同時に発注することをおすすめします。

NO. 符号	PARTS NO. 部品番号	PARTS NAME	部品名称	DWG NO. 図面番号	QTY/UNIT			TYPE 形式	REMARKS 備考
					LXE10E-				
					A15F	A15G	A15H		
B16	1587959	High pressure transducer (HPT)	高圧圧力センサ (HPT)	3P141602-1	1	1	1	SPCH01	
B15	1587942	Low pressure transducer (LPT)	低圧圧力センサ (LPT)	3P141601-1	1	1	1	SPCL02	
E84	1605509	Heat shrinkable tube	熱収縮チューブ	4P151322-1	2	2	2		Must be applied when replacing above sensors. 上記圧力センサー交換時使用の事。

4. Order for temperature sensor

4. 温度センサーの発注

Refer to the following table for temperature sensors applied to this model.

この機種に使用されている温度センサーは下記の通りです。

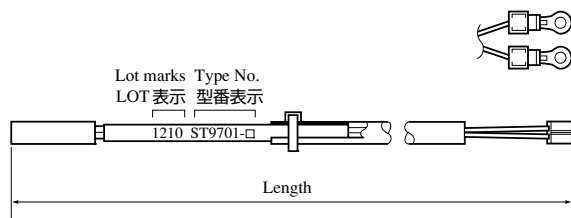

※Operating temp. range -30~+150°C
使用温度範囲 -30~+150°C

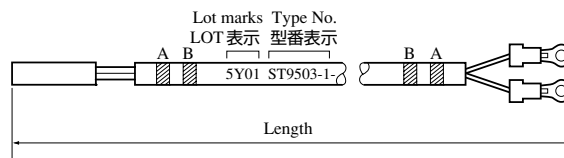

※Operating temp. range -30~+70°C
使用温度範囲 -30~+70°C

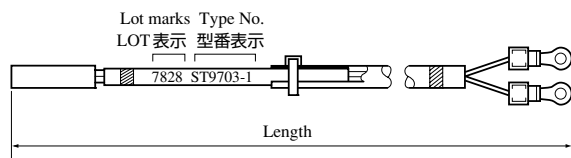

※Operating temp. range -30~+15°C
使用温度範囲 -30~+15°C

呼称	NO. 符号	PARTS NO. 部品番号	PARTS NAME	部品名称	DWG. NO. 図番	TYPE 形式	WIRE COLOR 配線色		LENGTH 全長mm	QTY/UNIT LXE10E-			TEMPORALY EXCHANGABILITY 緊急時互換性
							A	B		A15F	A15G	A15H	
1. SS	C24	1713330	Supply air temp. sensor	吹出空気温度センサー	3PA61769-16	ST9503-16	green 緑	-	3100	1	1	1	○
2. DSS	C25	1713347	Data recorder supply air temp. sensor	データレコーダ吹出空気温度センサー	3PA61769-17	ST9503-17	green 緑	Red 赤	3100	1	1	1	○
3. RS	C26	1713354	Return air temp. sensor	吸込空気温度センサー	3PA61769-18	ST9503-18	Blue 青	-	2900	1	1	1	○
4. DRS	C27	1713361	Data recorder return air temp. sensor	データレコーダ吸込空気温度センサー	3PA61769-19	ST9503-19	Blue 青	Red 赤	3100	1	1	1	○
5. EIS	D4	156282J	Evaporator inlet temp. sensor	蒸発器入口温度センサー	3P012118-2	ST9703-2	Brown 茶	-	2500	1	1	1	
6. EOS	D5	156283J	Evaporator outlet temp. sensor	蒸発器出口温度センサー	3PA61769-15	ST9503-15	Yellow 黄	-	2600	1	1	1	○
7. DCHS	B11	098332J	Discharge pipe temp. sensor	吐出管温度センサー	3SA48009-10	ST9701-10	-	-	2910	1	1	1	
8. AMBS	B12	0798321	Ambient air temp. sensor	外気温度センサー	3PA61769-6	ST9503-6	-	-	2600	1	1	1	○
9. SGS	B13	098333J	Compressor suction gas temp. sensor	圧縮機吸入ガス温度センサー	3PA61769-9	ST9503-9	White 白	-	2900	1	1	1	○

1. Tools for emergency operation

1. 緊急運転用工具

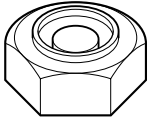
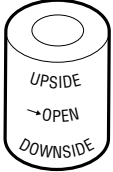
NO. 符号	PARTS NO. 部品番号	PARTS NAME	部品名称	DWG NO. 図面番号	USE 用途	ILLUSTRATION 姿図
-	1080263	Emergency coil cap	エマージェンシー コイルキャップ	3P017370-1	For electronic expansion valve 電子膨張弁用	
-	1270530	Emergency magnet	エマージェンシー マグネット	2P078385-2	Suction modulating valve 吸入比例弁用	

(See Service Manual for application.)

(使用方法はサービスマニュアルを参照ください。)

2. Personal computer cable (for DCCS)

2. パソコンケーブル（DCCS用）

The following parts are connector cables required to exchange information between the refrigeration unit and personal computer. The table below describes parts required to apply to Model LXE-C, -D, and -E new model.

下記の部品は冷凍ユニットとパソコンの情報交換に必要なコネクタ、ケーブル類です。LXE-C型、D型、及び新機種E型対応に必要な部品を掲載しています。

[TYPE A]タイプA

LXE10C LXE10CA LXE10D for MOL	LXE10C LXE10CA MOL用LXE10D	
(Receptacle) RS232C (Female) on the controller	(レセプタクル) RS232C (メス) コントローラー側	

[TYPE B]タイプB

LXE10D LXE10E	LXE10D LXE10E	
(Receptacle) Water proof type on the unit	(レセプタクル) コンテナ冷凍機 ユニットの防水型	

(1) Parts No.

(1) 部品番号

NO. 符号	PARTS NO. 部品番号	PARTS NAME	部品名称	REMARKS 備考
①	Local supply 市販品	Connection cable (reverse)	接続ケーブル (リバース)	RS232C reverse (cross) type RS232Cリバース (クロス) 型
②	9993324	Connection cable	接続ケーブル	
③	Local supply 市販品	Adapter (gender changer)	アダプター (ジェンダーチェンジャー)	D-sub 9P, Male-Male Dサブ9ピン、オス-オス
④	1087149	Connection cable (3 Pins)	接続ケーブル (3ピン)	LXE10E-A Standard LXE10E-A標準
⑤	1384509	Connection cable (5 Pins)	接続ケーブル (5ピン)	For LXE10E-A14,A15 LXE10E-A14、A15用

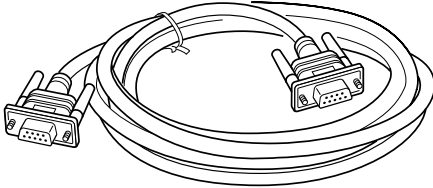
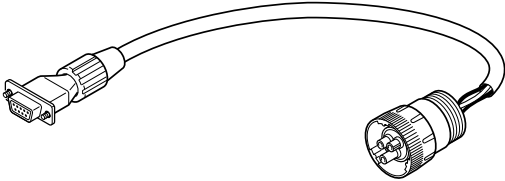
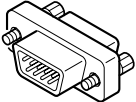
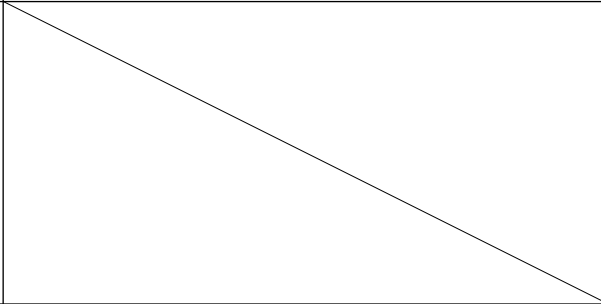
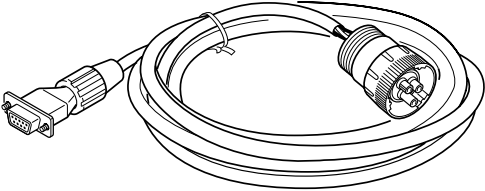
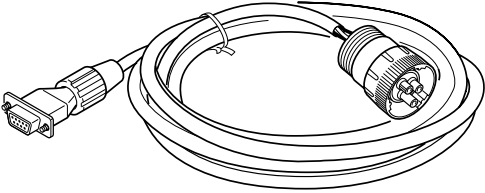
NO. 符号	Illustration 姿図	Internal Wiring 内部配線																														
①		<p>RS232C Female RS232C Female</p> <p>メス メス</p> <table border="0"> <tr><td>1</td><td>↔</td><td>1</td></tr> <tr><td>2</td><td>↔</td><td>2</td></tr> <tr><td>3</td><td>↔</td><td>3</td></tr> <tr><td>4</td><td>↔</td><td>4</td></tr> <tr><td>5</td><td>↔</td><td>5</td></tr> <tr><td>6</td><td>↔</td><td>6</td></tr> <tr><td>7</td><td>↔</td><td>7</td></tr> <tr><td>8</td><td>↔</td><td>8</td></tr> <tr><td>Frame</td><td></td><td>Frame</td></tr> <tr><td>フレーム</td><td></td><td>フレーム</td></tr> </table>	1	↔	1	2	↔	2	3	↔	3	4	↔	4	5	↔	5	6	↔	6	7	↔	7	8	↔	8	Frame		Frame	フレーム		フレーム
1	↔	1																														
2	↔	2																														
3	↔	3																														
4	↔	4																														
5	↔	5																														
6	↔	6																														
7	↔	7																														
8	↔	8																														
Frame		Frame																														
フレーム		フレーム																														
②		<p>Daikin made RS232C Female</p> <p>ダイキン製 メス</p> <table border="0"> <tr><td>A</td><td>Red</td><td>1</td></tr> <tr><td>B</td><td>White</td><td>2</td></tr> <tr><td>C</td><td>Black</td><td>3</td></tr> <tr><td></td><td></td><td>4</td></tr> <tr><td></td><td></td><td>5</td></tr> <tr><td></td><td></td><td>6</td></tr> <tr><td></td><td></td><td>7</td></tr> <tr><td></td><td></td><td>8</td></tr> <tr><td></td><td></td><td>9</td></tr> </table>	A	Red	1	B	White	2	C	Black	3			4			5			6			7			8			9			
A	Red	1																														
B	White	2																														
C	Black	3																														
		4																														
		5																														
		6																														
		7																														
		8																														
		9																														
③																																
④		<p>Daikin made RS232C Female</p> <p>ダイキン製 メス</p> <table border="0"> <tr><td>A</td><td>Red 赤</td><td>1</td></tr> <tr><td>B</td><td></td><td>2</td></tr> <tr><td>C</td><td>White 白</td><td>3</td></tr> <tr><td></td><td>Black 黒</td><td>4</td></tr> <tr><td></td><td></td><td>5</td></tr> <tr><td></td><td></td><td>6</td></tr> <tr><td></td><td></td><td>7</td></tr> <tr><td></td><td></td><td>8</td></tr> <tr><td></td><td></td><td>Frame</td></tr> <tr><td></td><td></td><td>フレーム</td></tr> </table>	A	Red 赤	1	B		2	C	White 白	3		Black 黒	4			5			6			7			8			Frame			フレーム
A	Red 赤	1																														
B		2																														
C	White 白	3																														
	Black 黒	4																														
		5																														
		6																														
		7																														
		8																														
		Frame																														
		フレーム																														
⑤		<p>Daikin made RS232C Female</p> <p>ダイキン製 メス</p> <table border="0"> <tr><td>A</td><td>Red 赤</td><td>1</td></tr> <tr><td>B</td><td></td><td>2</td></tr> <tr><td>C</td><td>White 白</td><td>3</td></tr> <tr><td>D</td><td></td><td>4</td></tr> <tr><td>E</td><td>Black 黒</td><td>5</td></tr> <tr><td></td><td></td><td>6</td></tr> <tr><td></td><td></td><td>7</td></tr> <tr><td></td><td></td><td>8</td></tr> <tr><td></td><td></td><td>Frame</td></tr> <tr><td></td><td></td><td>フレーム</td></tr> </table>	A	Red 赤	1	B		2	C	White 白	3	D		4	E	Black 黒	5			6			7			8			Frame			フレーム
A	Red 赤	1																														
B		2																														
C	White 白	3																														
D		4																														
E	Black 黒	5																														
		6																														
		7																														
		8																														
		Frame																														
		フレーム																														

<https://daikin-p.ru>

MEMO

<https://daikin-p.ru>

大金工业株式会社

DAIKIN INDUSTRIES,LTD.

总 公 司：大阪市北区中崎西 2 丁目 4-12
梅田中心大厦(邮政编号：530-8323)
电话：06-6373-4338
传真：06-6373-7297

东京分公司：东京都港区港南 2-18-1
JR 品川东楼（邮政编号：108-0075）
电话：03-6716-0420
传真：03-6716-0230

Head Office. Umeda Center Bldg., 4-12, Nakazaki-Nishi 2-chome, Kita-ku, Osaka, 530-8323 Japan.

Tel: 06-6373-4338

Fax: 06-6373-7297

Tokyo Office. JR Shinagawa East Bldg., 10F 18-1, Konan 2-chome, Minato-ku Tokyo, 108-0075 Japan.

Tel: 03-6716-0420

Fax: 03-6716-0230