

DAIKIN

Marine type

Container Refrigeration Unit

Service manual

Model

LXE5A-C(T)

LXE5A-CA(T)

LXE5-C(T)

LXE5-CA(T)

DAIKIN INDUSTRIES, LTD.

TR86-52D

This manual describes the features, functions, operation, and maintenance of the container refrigeration unit. In addition, please refer also to these manuals.

- Parts list
- Supplement (for the unit which has special specifications)

NOMENCLATURE

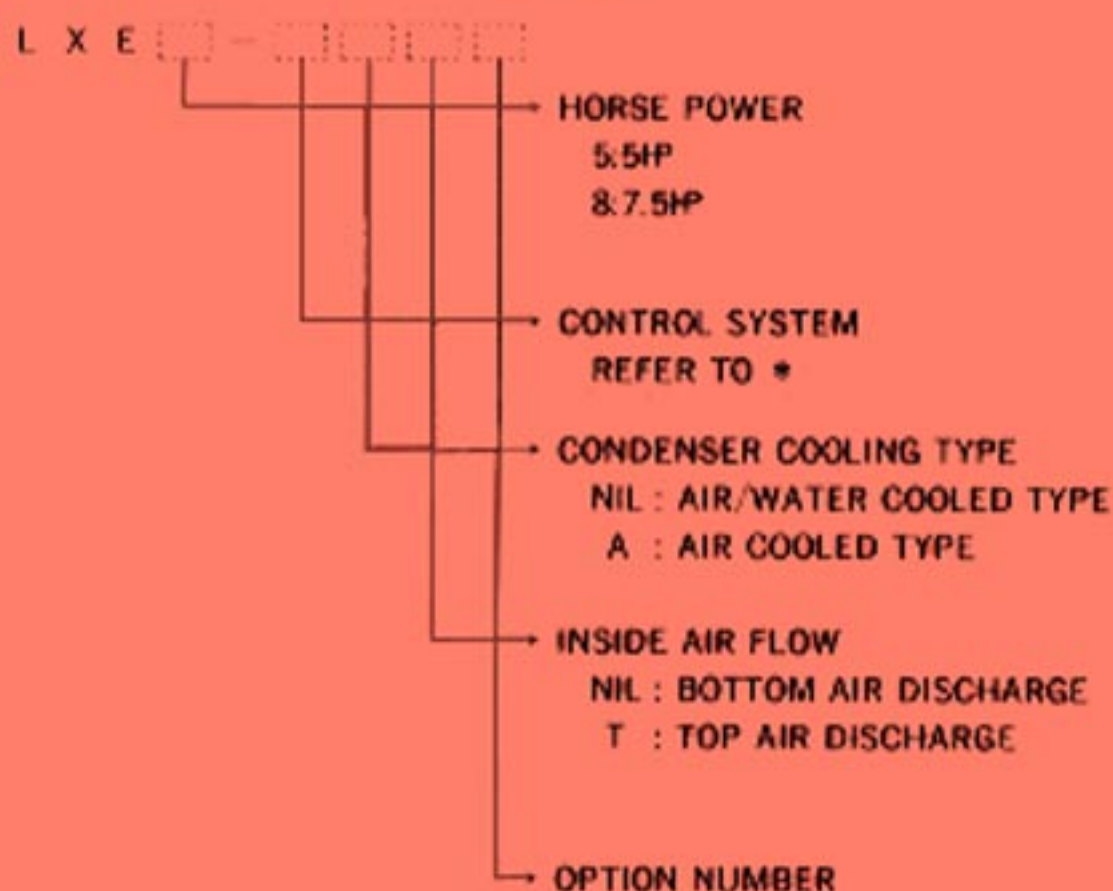

* (NIL) : DECOS (DAIKIN ELECTRONIC CONTAINER OPERATION SYSTEM)

- C : COMP. ON/OFF CONTROL
- H : COMP. ON/OFF + HOT GAS BYPASS CONTROL
- R : RMC (REFRIGERATING MACHINE CONTROLS)
- E : DECOS + ELECTRONIC RECORDER

NOTE)1. THERE ARE SEVERAL STANDARD SERVICE MANUALS & PARTS LISTS FOR EACH CONTROL SYSTEM. PLEASE USE PROPER SERVICE MANUAL & PARTS LIST.

2. "R" GIVEN AFTER OPTION NUMBER STANDS FOR "REVISE" AND IT IS GIVEN FOR THE UNIT WHICH IS SPECIALLY MODIFIED.

DANGER

1. Do not disconnect plug until power supply is shut off.
2. Do not touch the condenser fan during water cooled operation. (The condenser fan operates on and off to cool the switch box.)
3. Change over the cam switch before connecting the power plug.

CAUTION

Do not start the unit until a plug is connected and generator plant is operated.

NOTE

1. Confirm the function of the temperature recorder and life of the battery when the chart paper is replaced with a new one. Properly set the date of chart paper.
2. Firmly tighten the covers of the switch box and control box not to make water ingress.
3. Confirm that the stop valves in the refrigeration circuit are opened before operation.
4. Confirm that the cargos are cooled down to the temperature for transportation in advance.
5. After operating the container refrigeration unit for service, wash the unit with fresh water, especially the external section of the unit carefully, because much salt sticks on the unit.

Relevant models

The following models are described in this service manual.

| Model | LXE5(A)-C | LXE5(A)-CT | LXE5(A)-CA | LXE5(A)-CAT |
|--------------------------------|---------------------------|------------------------|---------------------------|------------------------|
| Inside air discharge direction | Bottom air discharge type | Top air discharge type | Bottom air discharge type | Top air discharge type |
| Condenser cooling type | Air/water cooled type | Air/water cooled type | Air cooled type | Air cooled type |

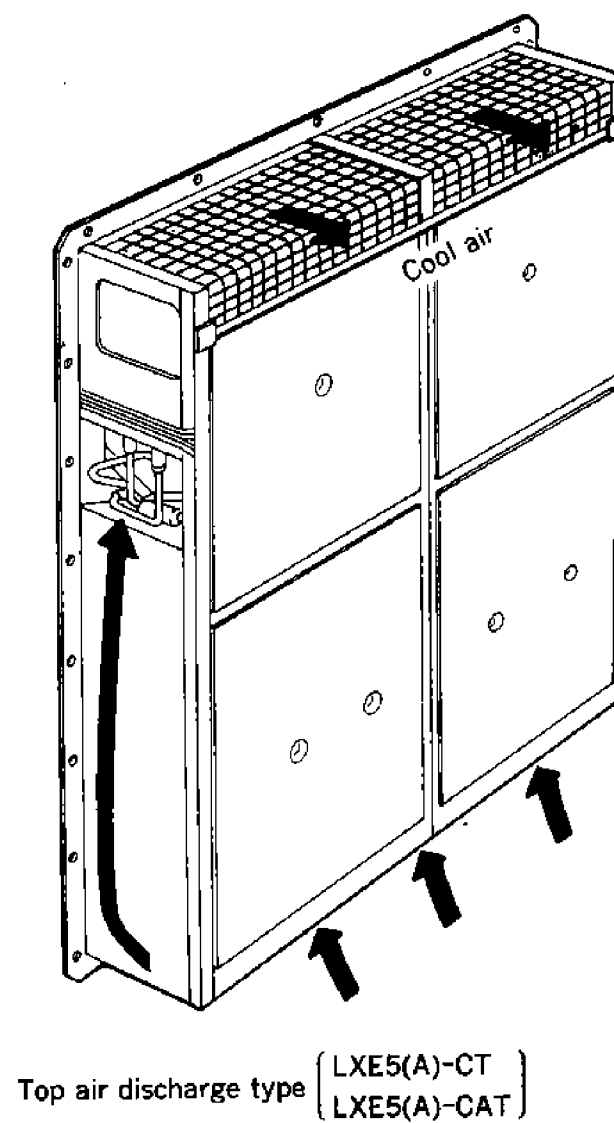
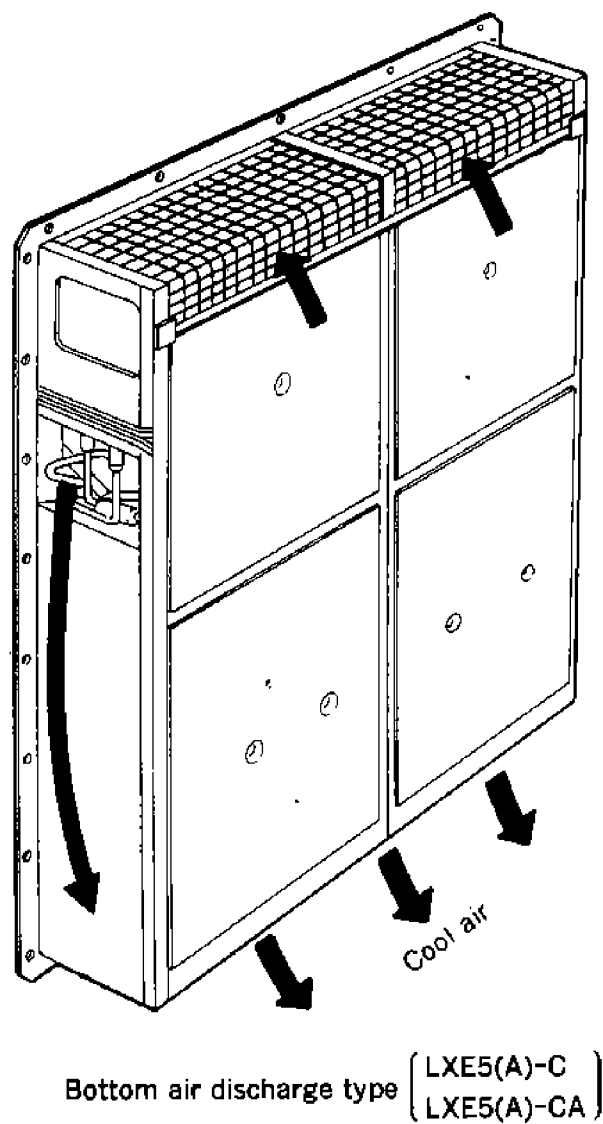
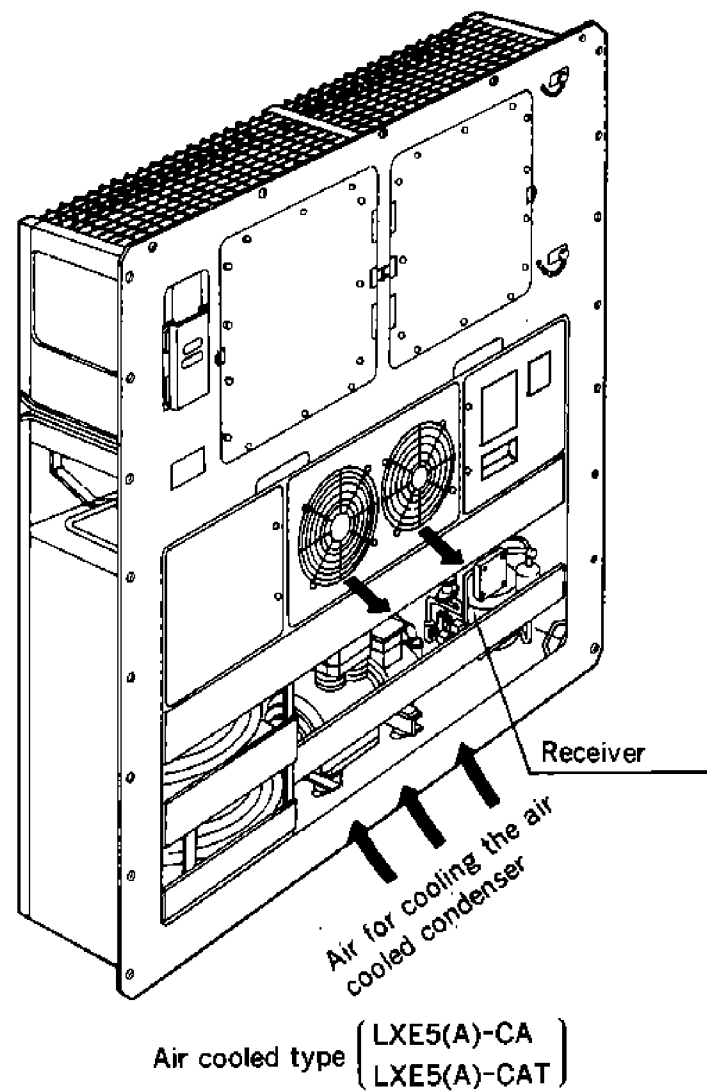
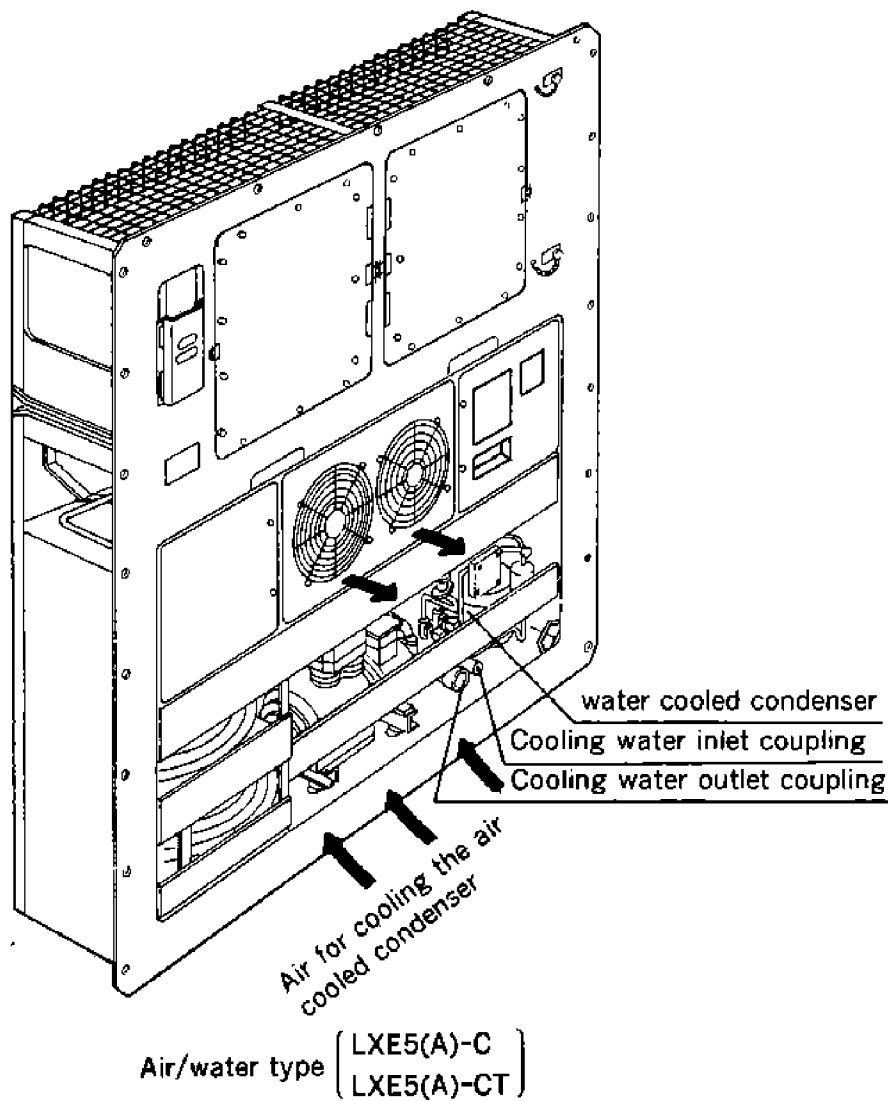

Contents

Chapter for operation

| | |
|---------------------------------------|---|
| 1. Operation ranges | 2 |
| 2. Names of parts | 2 |
| 3. Operation | 3 |
| 3.1 Preparation and operation | 3 |
| 3.2 Checking during operation | 6 |
| 3.3 Maintenance after operation | 6 |
| 3.4 Switches and pilot lamps | 7 |

Chapter for maintenance and repair

| | |
|---|----|
| 1. Data of the products | 10 |
| 1.1 Main specifications | 10 |
| 1.2 Names of parts | 11 |
| 1.2.1 Outside | 11 |
| 1.2.2 Inside | 12 |
| 1.2.3 ① Switch box (Products after '90, 11) | 13 |
| ② Switch box (Products after '89, 2~before '90, 10) | 14 |
| ③ Switch box (Products before '89, 1) | 15 |
| 1.2.4 Control box | 16 |
| 1.3 Piping diagram | 17 |
| 1.4 Electric wiring diagrams | 18 |
| 1.4.1 Sequence | 18 |
| 1.4.2 Actual wiring diagram | 26 |
| 1.5 Set values of functional parts and protective devices | 36 |
| 1.6 Operation pressure and running current | 37 |
| 2. Operation modes and circuits | 38 |
| 2.1 How to read wiring diagrams | 38 |
| 2.2 High pressure control | 40 |
| 2.3 Air cooled and water cooled operation (Air/water cooled type) | 40 |
| 2.4 Voltage selector system | 41 |
| 2.5 Frozen operation | 43 |
| 2.6 Chilled operation | 45 |
| 2.7 Defrost operation | 47 |
| 2.8 Heat-up operation | 49 |
| 2.9 Refrigerant flow at each operation mode | 51 |
| 2.10 Pilot lamps and monitoring circuit | 52 |
| 3. Trouble and countermeasures | 53 |
| 4. PTI (Pretrip inspection) | 58 |
| 5. Major components and maintenance | 59 |
| 5.1 Components related with the refrigeration circuit | 59 |
| 5.1.1 Compressor | 59 |
| 5.1.2 Air cooled condenser and evaporator | 59 |
| 5.1.3 Water cooled condenser (Air/water cooled type) | 59 |
| Receiver (Air cooled type) | |
| 5.1.4 Expansion valve | 60 |
| 5.1.5 Liquid/moisture indicator | 61 |
| 5.1.6 Dryer | 62 |
| 5.1.7 Solenoid valves | 62 |
| 5.1.8 Check valve | 63 |
| 5.2 Components related with the air system | 64 |
| 5.2.1 Fans and motors | 64 |
| 5.2.2 Ventilator | 64 |
| 5.3 Functional electric parts | 65 |
| 5.3.1 High pressure switch (63H1) | 65 |
| 5.3.2 Low pressure switch (63L) | 65 |
| 5.3.3 High pressure control switch (63H2) | 65 |
| 5.3.4 Water pressure switch (63W) (Air/water cooled type) | 65 |
| 5.3.5 Oil pressure protection switch (63QL) (Option) | 65 |
| 5.3.6 Recorder (SKM-2924A) | 66 |
| 5.3.7 Defrost termination thermistor (26D) | 68 |
| 5.3.8 Phase-reversal relay (47) | 69 |
| 5.3.9 Printed circuit board for control (23A1) | 70 |
| 5.3.10 Electronic controller (23A2) | 73 |
| 6. Maintenance | 77 |
| 6.1 Handling method of the stop valves | 77 |
| 6.2 Attaching or removing points of pressure gauges | 78 |
| 6.3 Pump down | 79 |
| 6.4 Charging and purging the refrigerant, refrigeration oil | 79 |
| 6.5 Check points for high pressure switch | 81 |

<https://daikin-p.ru>

Chapter for operation

1. Operation ranges

Use the units within the following ranges

| Item | Operation range | |
|--|---|----------------------------|
| Ambient temperature range | -30°C~+50°C (-22°F~+122°F) | |
| Cooling water (air/water cooled type) | Quality of water | Fresh water |
| | Temperature | 10°C~36°C (50°F~96.8°F) |
| | Water flow rate | 20~35 ℓ /min. (Usually 27) |
| | Pressure | 2~5kg/cm ² |
| Inside temperature range | -25°C~+25°C (-13°F~+77°F) | |
| Voltage | 200V class 200V 50/60Hz, 220V 60Hz | |
| | 400V class 380V~415V 50Hz, 400V~440V 60Hz | |
| | Voltage fluctuation rate ±10% | |
| Vibration and shock | 2G | |

2. Names of parts

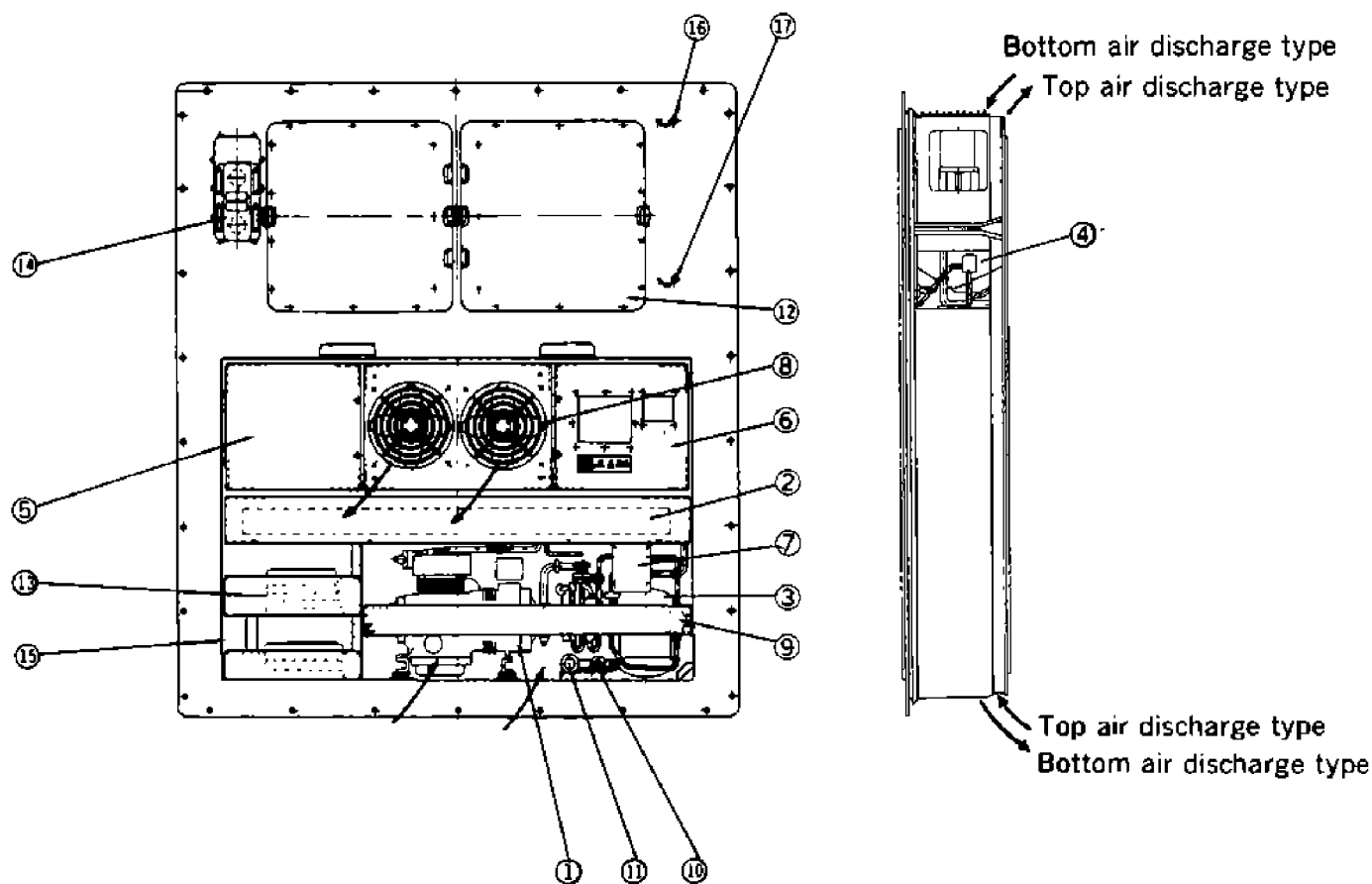

- | | | |
|---|---|--|
| <ul style="list-style-type: none"> ① Compressor ② Air cooled condenser ③ Water cooled condenser (Air/water cooled type) Receiver (Air cooled type) ④ Evaporator ⑤ Switch box { Breaker for main circuit, breaker for control circuit voltage selector switch are installed in the box. } ⑥ Control box { On the front, the operation switches are arranged, and controller and recorder are installed inside. } ⑦ Oil pressure protection switch box (Option) (The reset button is installed on the front cover of the box.) ⑧ Air cooled condenser fans { Operate during air cooled operation. Note that they sometimes operate to cool the switch box during water cooled operation. } ⑨ Dryer | <ul style="list-style-type: none"> ⑩ Cooling water inlet coupling ⑪ Cooling water outlet coupling (Air/water cooled type) | } Connect the water piping to them before water cooled operation, and air cooled operation is automatically changed to water cooled operation. |
| <ul style="list-style-type: none"> ⑫ Access panel ⑬ Storage space for power cable ⑭ Ventilator ⑮ Transformer ⑯ Bottom air discharge type : Thermometer check point Top air discharge type : Gas sampling port ⑰ Bottom air discharge type : Gas sampling port Top air discharge type : Thermometer check point | <ul style="list-style-type: none"> ○ Thermometer check point (Use this port to measure inside temperature) ○ Gas sampling port { This port is available for CO₂ gas sampling as well as thermometer check point. } | |

3. Operation

Operate the unit by the procedures given below.

- Preparation and operation
- Checking during operation
- Maintenance after operation

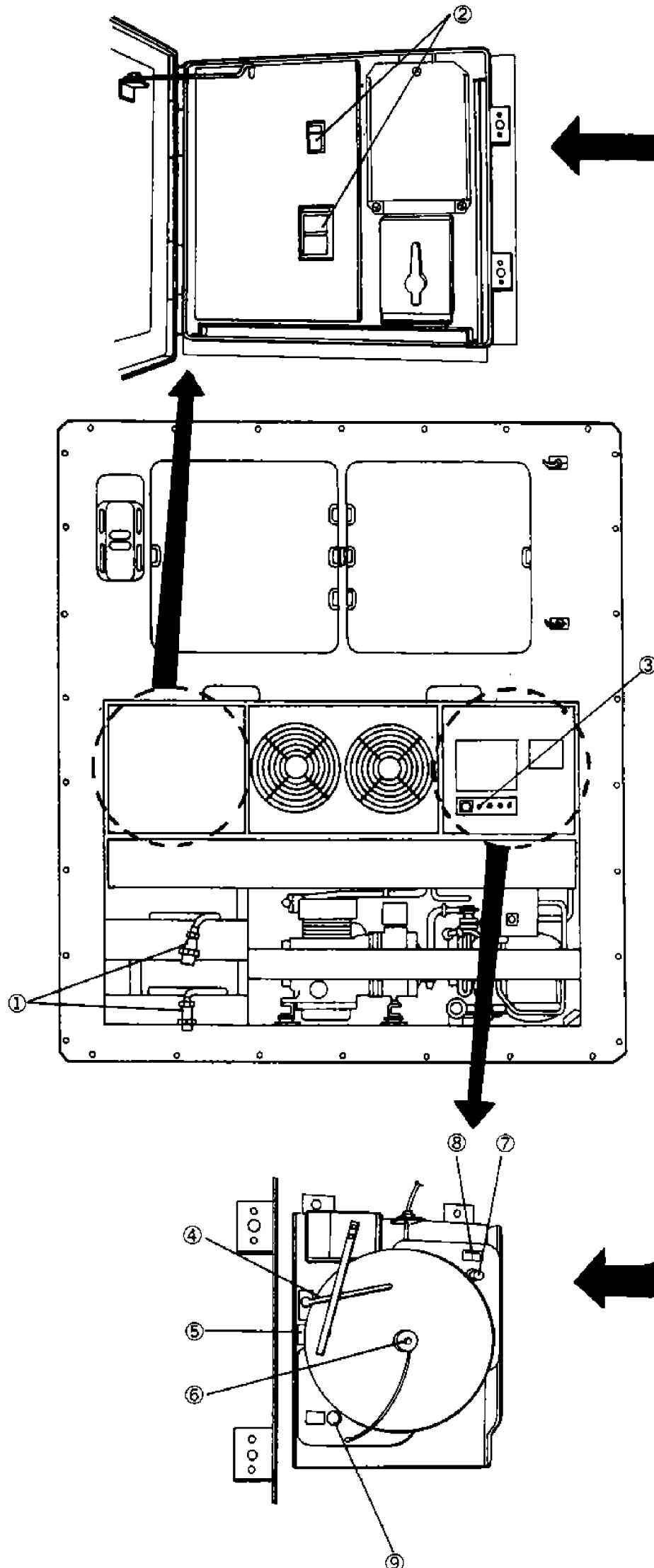

3.1 Preparation and operation

Confirm that supply power is off.

Confirm that the power source ①, the circuit breaker ② and unit ON-OFF switch ③ are turned off before checking for safety's sake.

Confirming function of drive for the recording chart

- Confirming life of a dry element battery
Press the push button ⑦ and confirm that the needle of the remaining voltage indicator ⑧ remains in the blue zone. (The meter functions only when the push button ⑦ is pressed down)
- Confirming the function of quartz motor
After confirming the life of dry element battery, check through the inspection window ⑨ the inside fly wheel is rotating.

Setting a sheet of recording paper

- Raise the pen by the pen holder ④, loosen the chart nut ⑥, and set a new sheet of recording paper.
- Set the date on the paper to an arrow of present time plate ⑤.
- Firmly tighten up the chart nut ⑥ and release the pen so that recording can be accomplished.

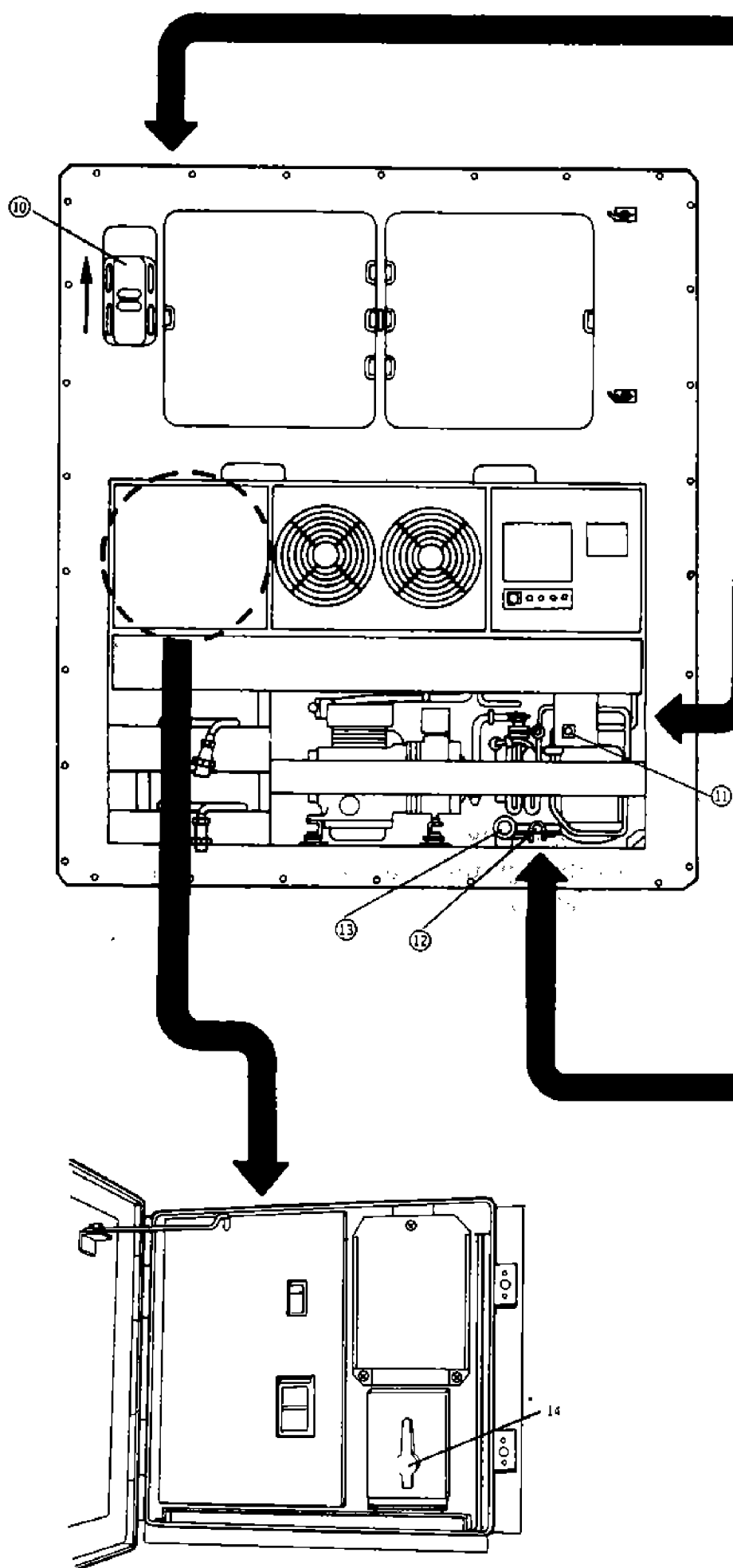

Open or close the ventilator.
Open or close the ventilator ⑩ according to the cargo.
(Be sure to keep it closed during transportation of frozen cargo.)

Reset the oil pressure protection switch. (Option)
Reset by pressing the button ⑪ on the front panel of the PS (Pressure switch) box. The unit does not start unless the switch is reset.

Connect the cooling water piping. (Air/water cooled type)

- In the case of water cooled operation, connect the water piping, and supply water through it.
- Connecting method
 1. Connect the cooling water inlet coupling ⑫.
 2. Connect the cooling water outlet coupling ⑬.
- Disconnecting method.
 1. Disconnect the cooling water outlet coupling ⑬.
 2. Disconnect the cooling water inlet coupling ⑫.

When the cooling water couplings are connected, insert the coupling on the ship side into the coupling on the unit side until a "click" is heard.

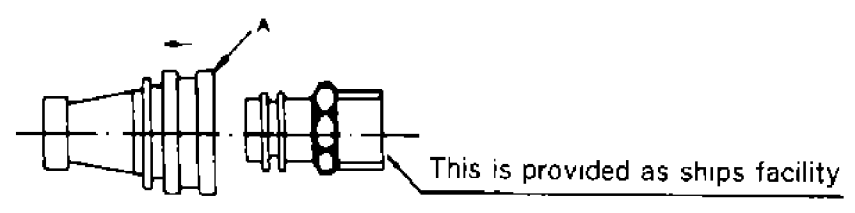

When disconnecting them, pull the coupling on the ship side toward you while pushing the "A" part of the female coupling in the direction pointed by an arrow mark.
Both at connecting and disconnecting, be careful for splash of cooling water.

Check that all refrigerant stop valves are opened.
(refer to "piping diagram")

Set the voltage selector ⑭ according to the supply voltage.

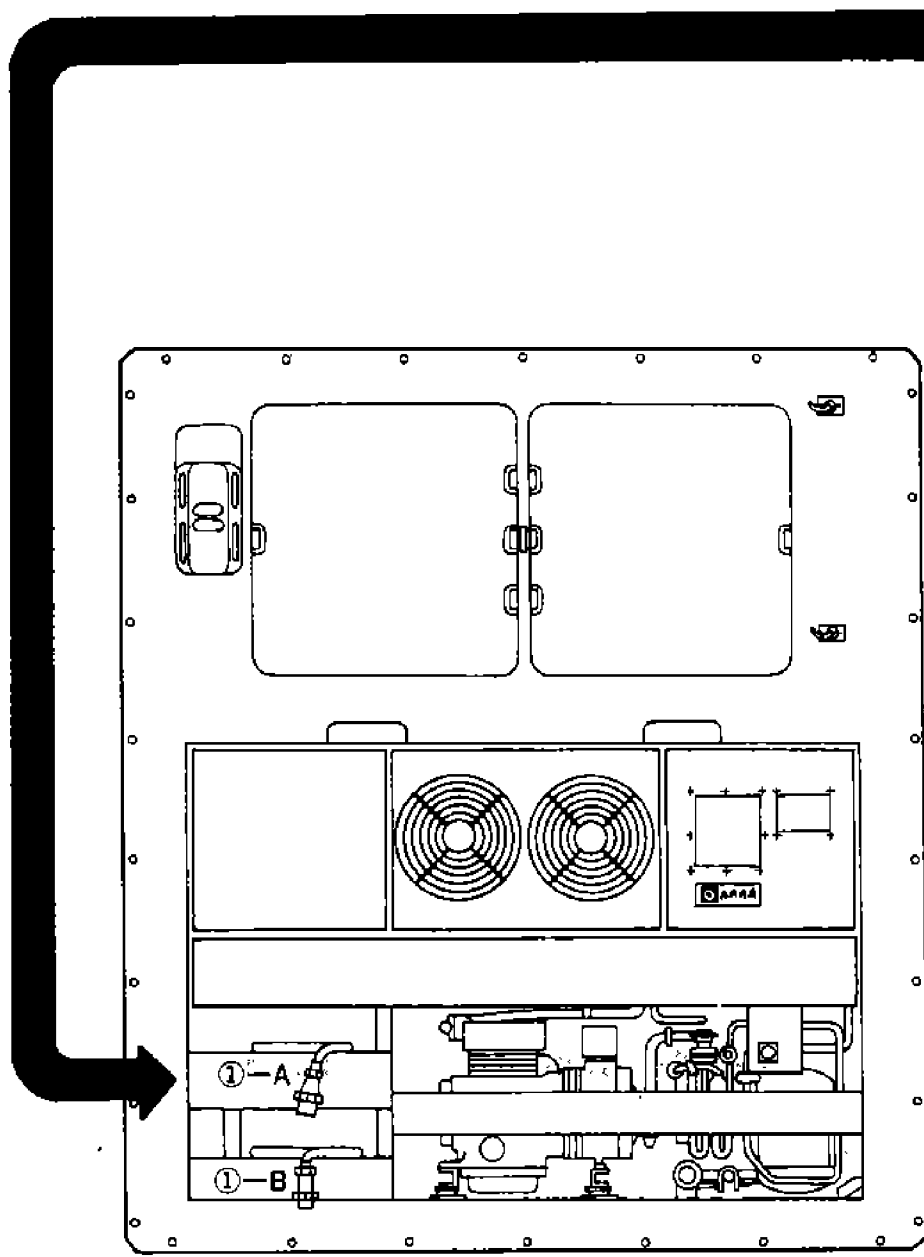

Plug ① in the power source which supplies the proper voltage, and fasten the plug ① firmly.

Turn on the power switch of the facility (outside the unit).

Turn ON the circuit breaker ② and unit ON-OFF switch ①.

Close the cover of the switch box.
If it is loose, water will intrude. Check around the packing and tighten the cover securely

- ① 電源プラグ
- ①-A 200V級
- ①-B 400V級

Note: In case the oil pressure switch is attached (Option).
If the unit stops 2~3 minutes after starting, the oil pressure protection switch in many cases has been activated.
If this happens, depress the reset button a few minutes after the unit stops. If it stops again, repeat the same action.

3.2 Checking during operation

| Checking items (precautions) | Method of check |
|---|---|
| 1. Check if unusual noise and vibration is not produced from compressor, fan and piping etc. | Visual, sensuous and touching. |
| 2. Check to ensure oil pressure protection switch does not function, and the unit does not stop. (Option) | — |
| 3. Check suction and discharge pressures of the compressor. (For installation of a gauge, refer to Section 6 "Maintenance".) | Compare observed data with standard ones. |
| 4. Check for proper oil level of compressor. Check to see the oil is clean. (Oil level may fall for a while after starting, but it rises gradually.) | Visual Oil level should be approx. $\frac{1}{4}$ to $\frac{3}{4}$ of its full scale. |
| 5. Check to see if refrigerant is sufficient. (The refrigerant bubbles immediately after starting, but this does not mean that refrigerant is lacking.) | Shortage of refrigerant is indicated by bubbles in the moisture indicator. |
| 6. Check if any moisture is present in refrigerant circuit. (The color of moisture indicator may turn to orange if it has been exposed to gaseous refrigerant for a long time, but this is no indication of trouble.) | Visual The moisture indicator should normally appear deep blue. Orange color is a sign of trouble. |
| 7. Check if the recorder operates according to the inside temperature. | Visual |
| 8. Check operating conditions with the pilot lamps and check instrument | Visual |

3.3 Maintenance after operation

Stopping

To stop the unit, perform defrosting operation with the manual defrost switch and immediately turn off the unit ON-OFF switch after the compressor has stopped, (stop the unit with "pump-down" state.)
After pump down, turn off the circuit breaker.

Stowing the power cable

Turn the plug's opening downward so that sea and rain water cannot enter the plug when stowing it.

Close the cover of the switch box.

After water cooled operation, remove the water piping. (Air/water cooled type)

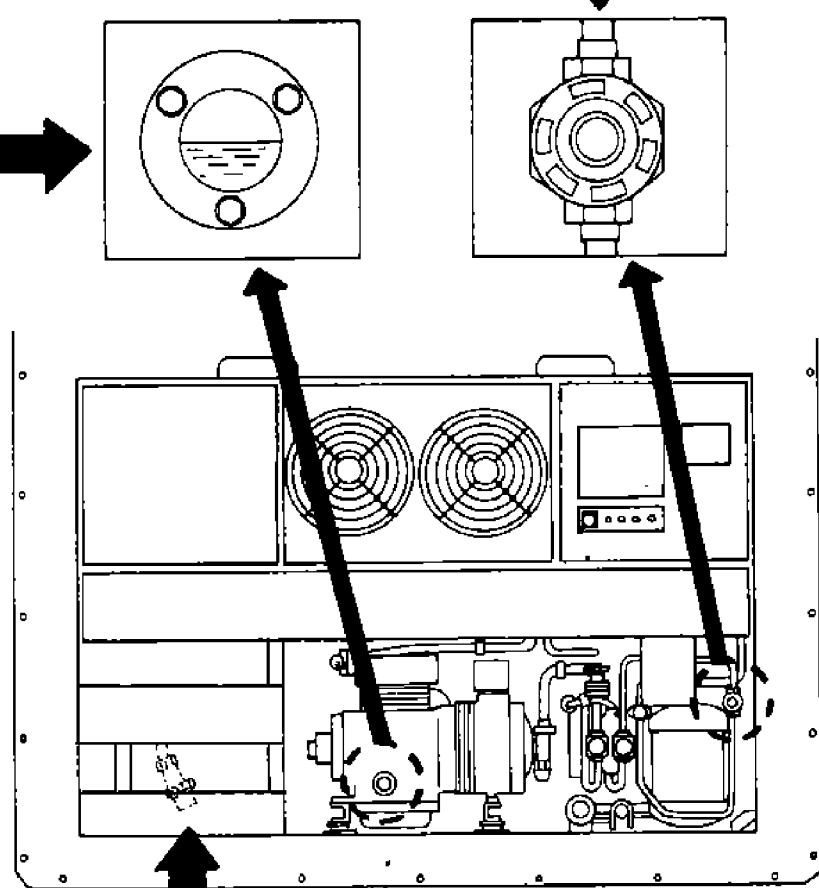

3.4 Switches and pilot lamps

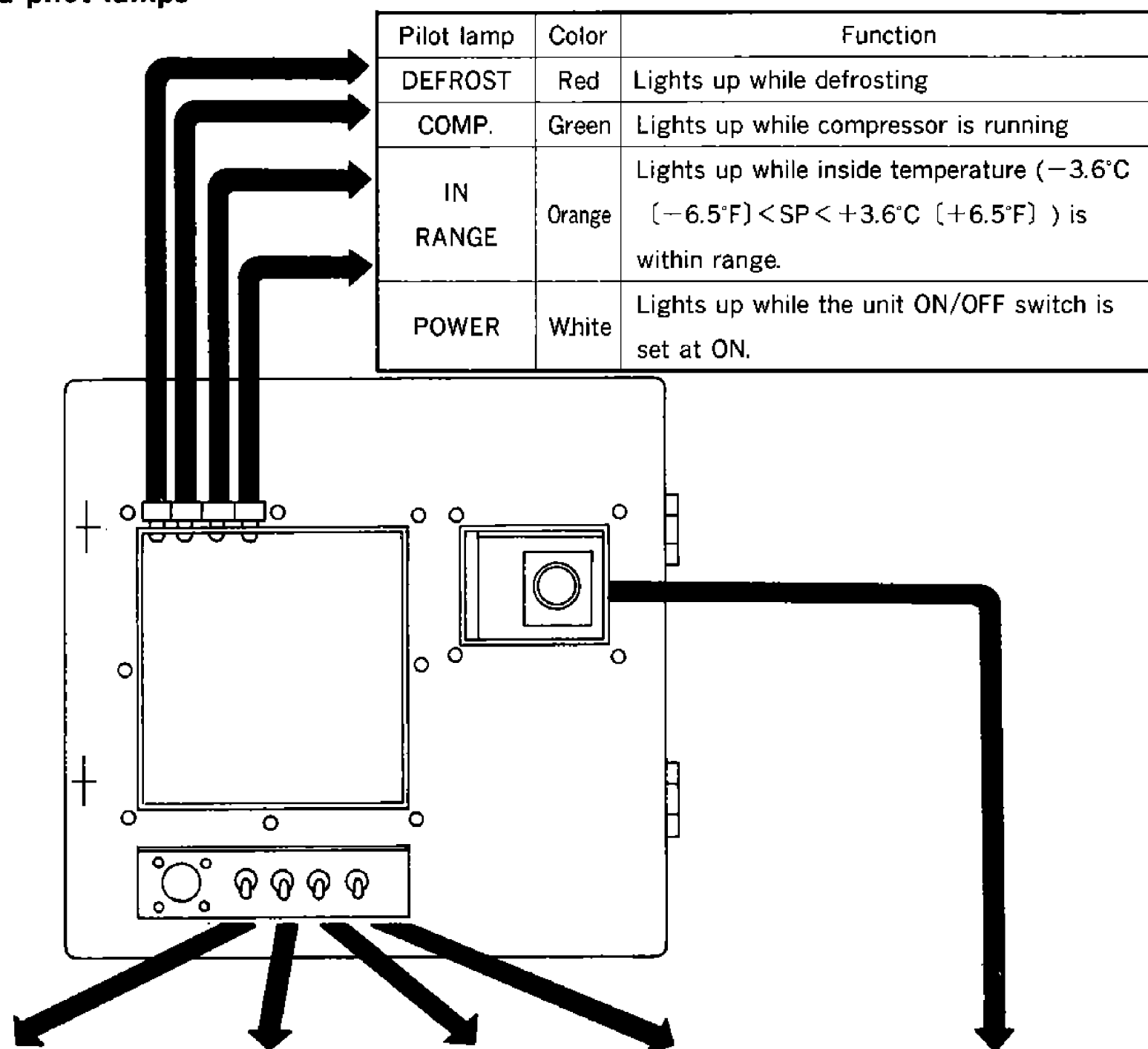

| Switch | Unit ON-OFF | Defrost AUTO-MANUAL | | Heat-up ON-OFF | Lamp ON-OFF | Set point selector | |
|-----------------|---|--|------------------------------|--|---------------------------|--|--|
| Operation mode | — | Defrost operation | | Heat-up operation | — | Chilled operation | Frozen operation |
| Operation point | Turn on the switch | Automatic Defrosting starts automatically by the timer S : 4Hr L : 12Hr | Manual Turn on the switch | Turn on the switch (Only for chilled operation) | Turn on the switch. | Set the set point to −4.5°C ~ +25°C. (+23.9°F ~ +77°F) | Set the set point to −25°C ~ −6.5°C (−13°F ~ +20.3°F) |
| Function | The unit is operated on and off. After turning on the switch, the evaporator fan will operate one minute later. | The unit is put in hot-gas defrost operation. After finishing defrost operation, the unit is automatically put in chilled or frozen operation. | | The unit is put in heat-up operation. After finishing heat-up operation, the unit is automatically put in chilled operation. | The pilot lamp lights up. | The unit is put in chilled operation and the evaporator fans operate in high speed. (If supply air temperature is above 20°C (68°F), evaporator fans operate in low speed.) | The unit is put in frozen operation, and the evaporator fans operate in low speed. |

<https://daikin-p.ru>

<https://daikin-p.ru>

Chapter for maintenance and repair

1. Data of the products

1.1 Main specifications

| Item | Model | LXE5(A)—C | LXE5(A)—CT | LXE5(A)—CA | LXE5(A)—CAT |
|--------------------------------|-------|--|------------------------|-----------------------------|------------------------|
| Inside air discharge direction | | Bottom air discharge type | Top air discharge type | Bottom air discharge type | Top air discharge type |
| Condenser cooling type | | Air/water cooled type | | Air cooled type | |
| Power supply | | AC 200V | 3 Phase 50Hz | | |
| | | AC 200V, 220V | 3 Phase 60Hz | | |
| | | AC 380~415V | 3 Phase 50Hz | | |
| | | AC 400V, 440V | 3 Phase 60Hz | | |
| | | (Dual-rating voltage system by voltage selector switch) | | | |
| Compressor | | Semi hermetic type (3.75 kW) | | | |
| Evaporator | | Cross finned coil type | | | |
| Air cooled condenser | | Cross finned coil type | | | |
| Water cooled condenser | | Vertical shell type | | — | |
| Fan | | Motor direct driven propeller type | | | |
| Fan motor | | Three-phase squirrel-cage induction motor | | | |
| Defrost | | | | | |
| Heating | | Hot-gas defrost | | | |
| Initiation | | Timer or manual switch | | | |
| Termination | | Sensing suction pipe temperature by the defrost termination thermistor | | | |
| Refrigerant control | | Thermostatic expansion valve | | | |
| Capacity control | | Compressor on/off system | | | |
| Protection devices | | Circuit breaker, over-current relay, compressor protective thermostat, fan motor protective thermostat, high pressure switch, and fusible safety plug, oil pressure protection switch (Option) | | | |
| Refrigerant (charged amount) | | R12 : 5.0 (kg)/11 (lbs).....LXE5-C(T), LXE5-CA(T) 4.0 (kg)/8.8 (lbs).....LXE5A-C(T), LXE5A-CA(T) | | | |
| Lubricant (charged amount) | | SUNISO 3GS-DI : 2.3 (ℓ) | | | |
| Weight | | Approx. 550 (kg)/1212 (lbs) | | Approx. 545 (kg)/1201 (lbs) | |

1.2 Names of parts

1.2.1 Outside

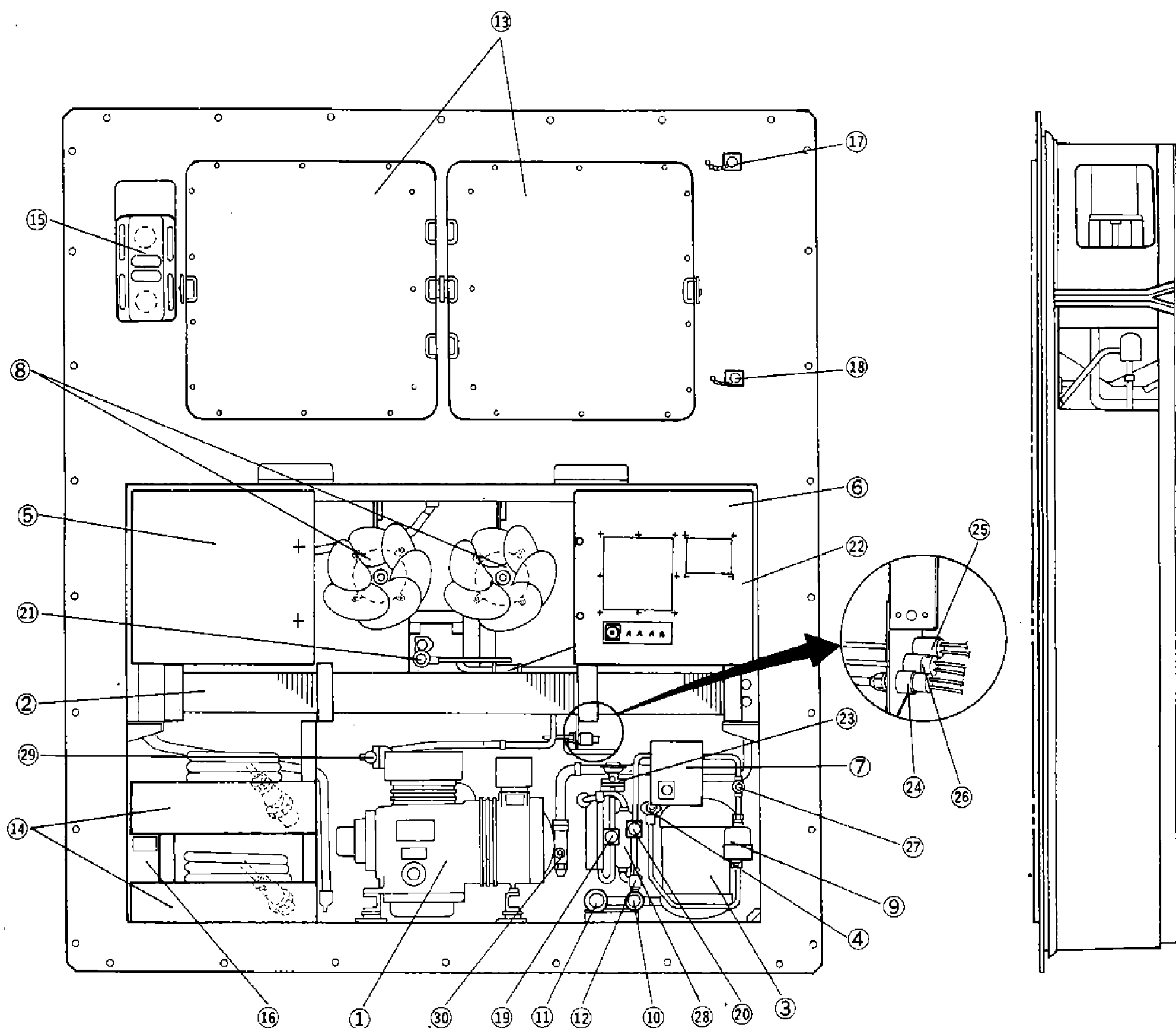

- | | | |
|---|---|---|
| ① Compressor | ⑬ Access panel | ⑳ Check valve |
| ② Air cooled condenser | ⑭ Storage space for power cable (Upper stage: 200V class Lower stage: 400V class) | ㉑ Expansion valve |
| ③ Water cooled condenser (Air/water cooled type) Receiver (Air cooled type) | ⑮ Ventilator | ㉒ High pressure switch (63H1) |
| ④ Stop valve at water cooled condenser (receiver) outlet side | ⑯ Transformer | ㉓ Low pressure switch (63L) |
| ⑤ Switch box | ⑰ ● Bottom air discharge type: Thermometer check point | ㉔ High pressure control switch (63H2) |
| ⑥ Control box | ● Top air discharge type: Gas sampling port | ㉕ Liquid/moisture indicator |
| ⑦ Oil pressure protection switch box (Option) | ⑱ ● Bottom air discharge type: Gas sampling port | ㉖ Accumulator (for defrosting) |
| ⑧ Air cooled condenser fan motor | ● Top air discharge type: Thermometer check point | ㉗ Stop valve at compressor discharge side |
| ⑨ Dryer | ⑲ Main liquid solenoid valve (20R1) | ㉘ Stop valve at compressor suction side |
| ⑩ Cooling water inlet coupling | ⑳ Measuring liquid solenoid valve (20R2) | |
| ⑪ Cooling water outlet coupling | ㉑ 3 way solenoid valve for defrosting (20R4) | |
| ⑫ Water pressure switch (63W) | | |

1.2.2 Inside

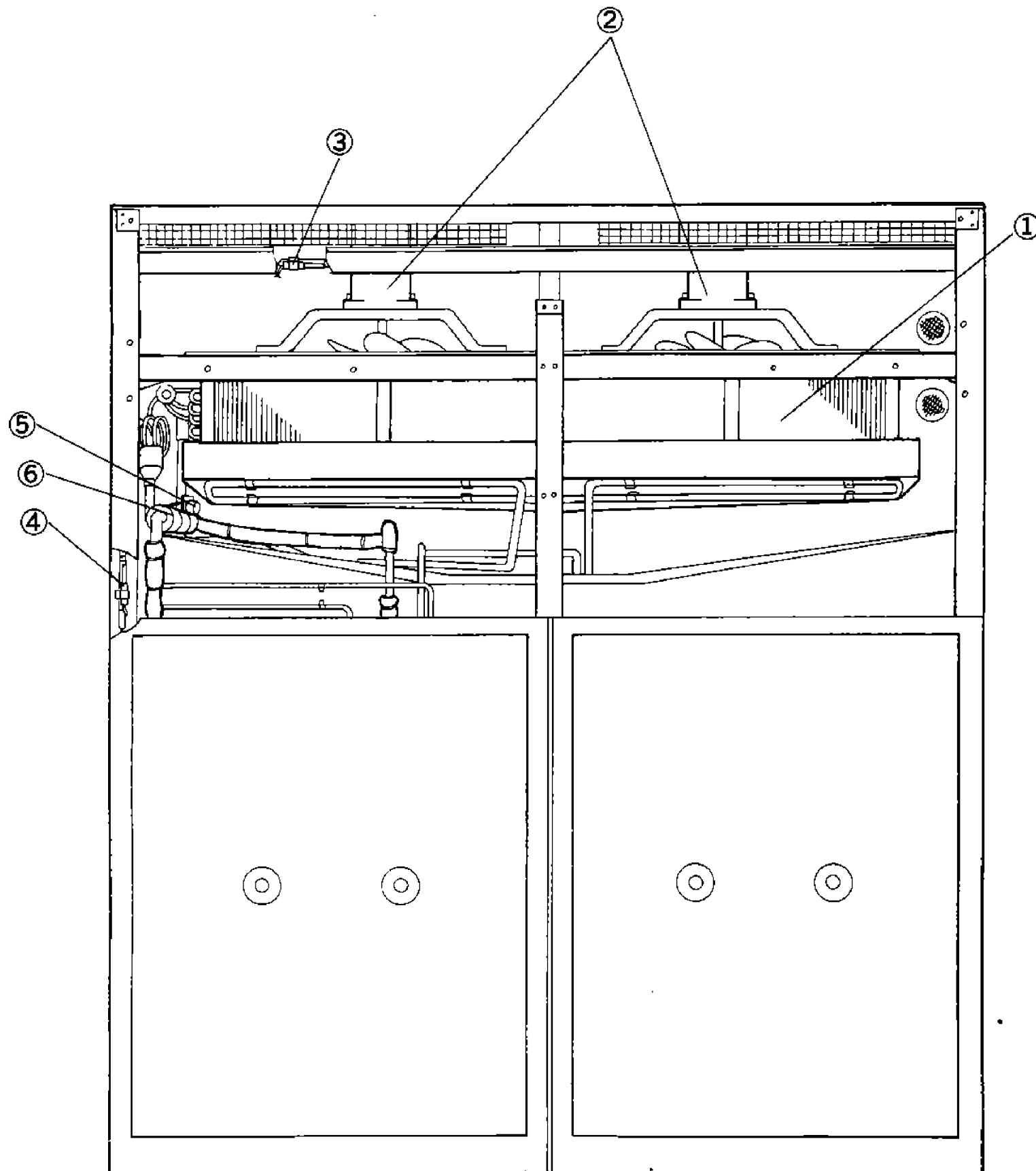

- ① Evaporator
- ② Evaporator fan motor
- ③ Bottom air discharge side: Return sensor and feeler tube (recorder)
Top air discharge side: Supply sensor
- ④ Bottom air discharge side: Supply sensor
Top air discharge side: Return sensor and feeler tube (recorder)
- ⑤ Defrost termination thermistor
- ⑥ Feeler tube (expansion valve)

1.2.3 ① Switch box (produced after November, 1990)

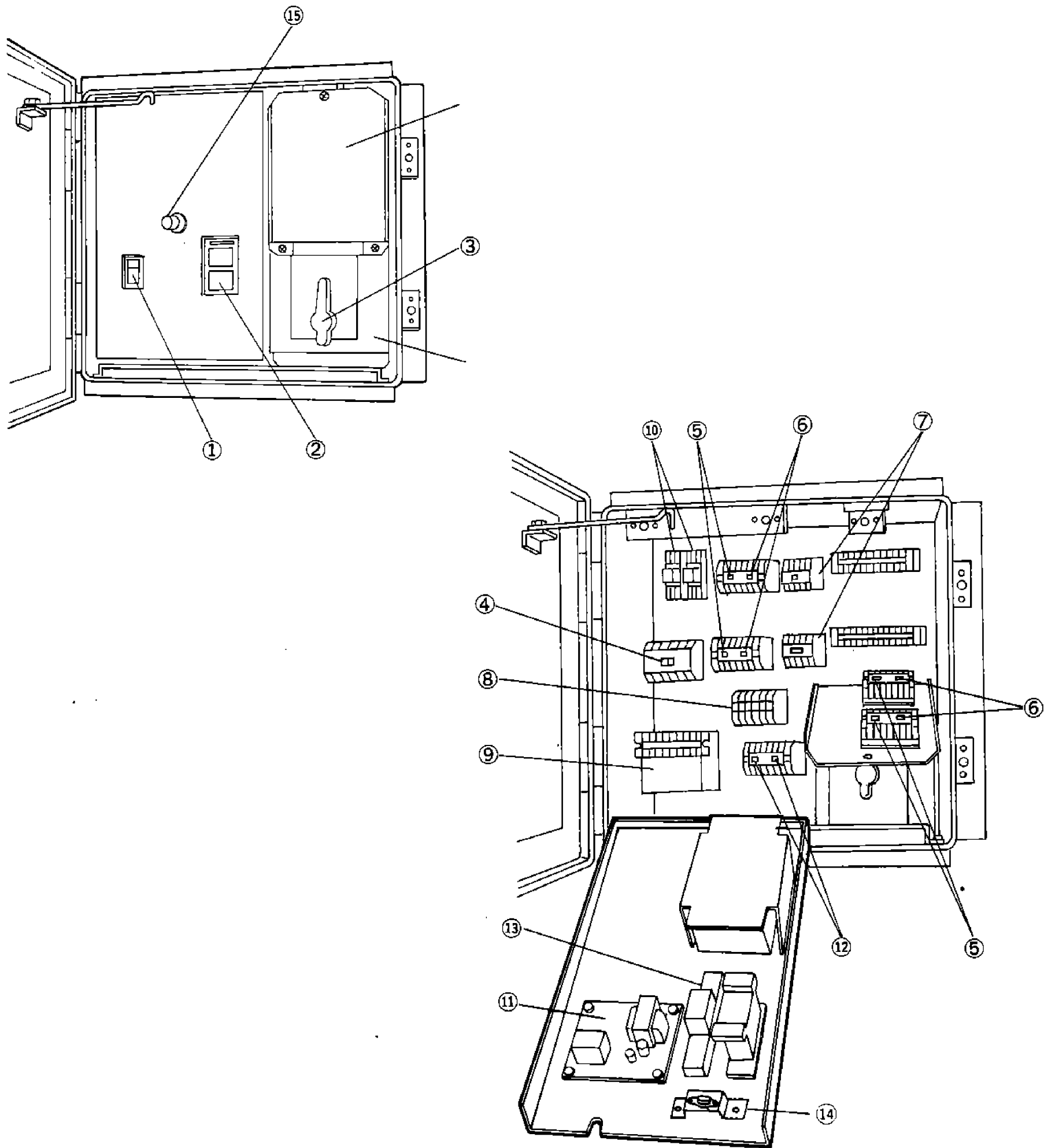

- ① Circuit breaker (52C2)
- ② Circuit breaker (52C1)
- ③ Voltage selector switch (83)
- ④ Magnetic contactor for compressor (88C)
- ⑤ Magnetic contactors for high speed evaporator fan motor (88EFH1-4)
- ⑥ Magnetic contactors for low speed evaporator fan motor (88EFL1-4)
- ⑦ Magnetic contactors for air cooled condenser fans (88CF1 · 2)
- ⑧ Over-current relay (51C)
- ⑨ Transformer (Tr2)
- ⑩ Auxiliary relays (49EFX1 · 2)
- ⑪ Phase sequence controller (47)
- ⑫ Magnetic contactors (47X1 · 2)
- ⑬ Auxiliary relay (63WX)
- ⑭ Switch box thermostat } Air/water cooled type

1.2.3② Switch box (Products after '89, 2~before '90, 10)

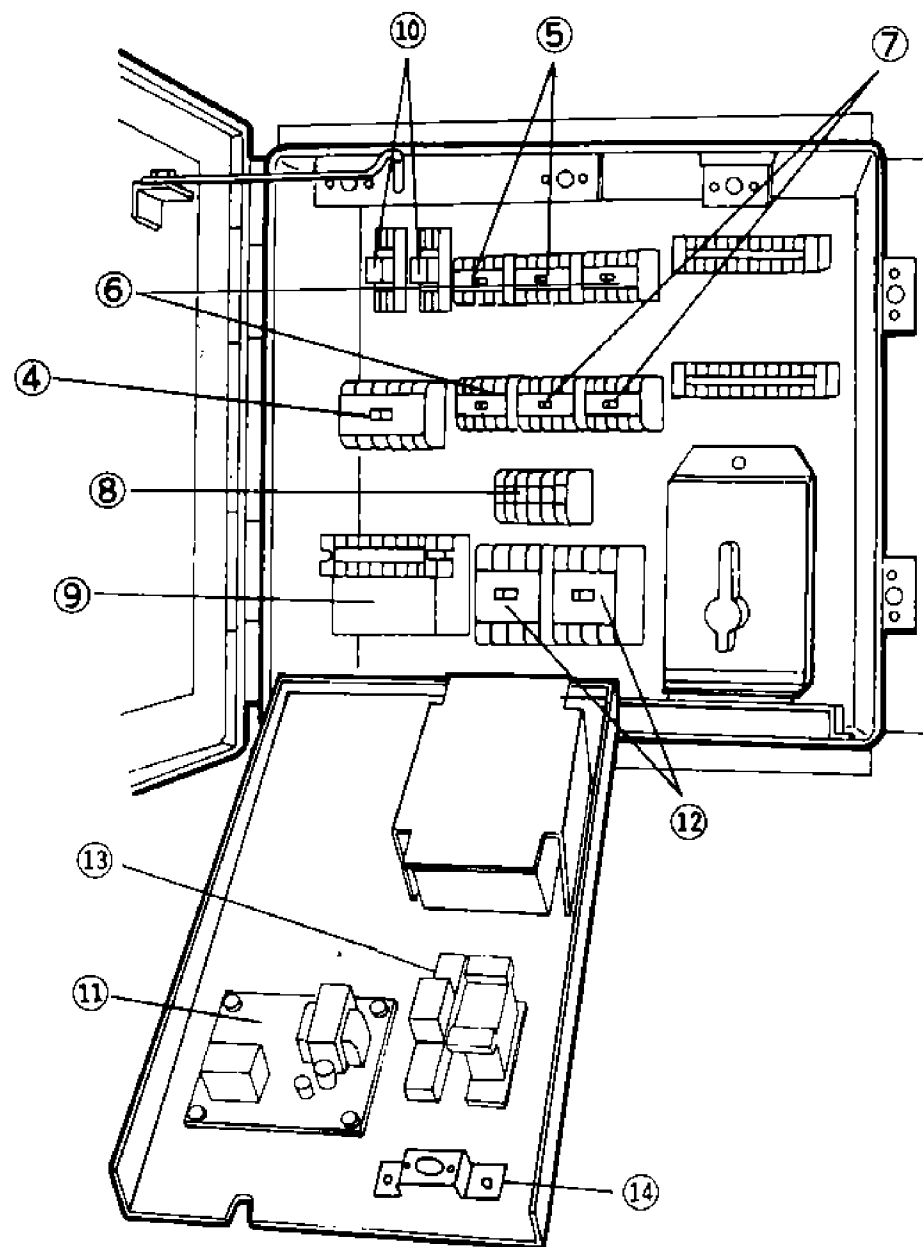
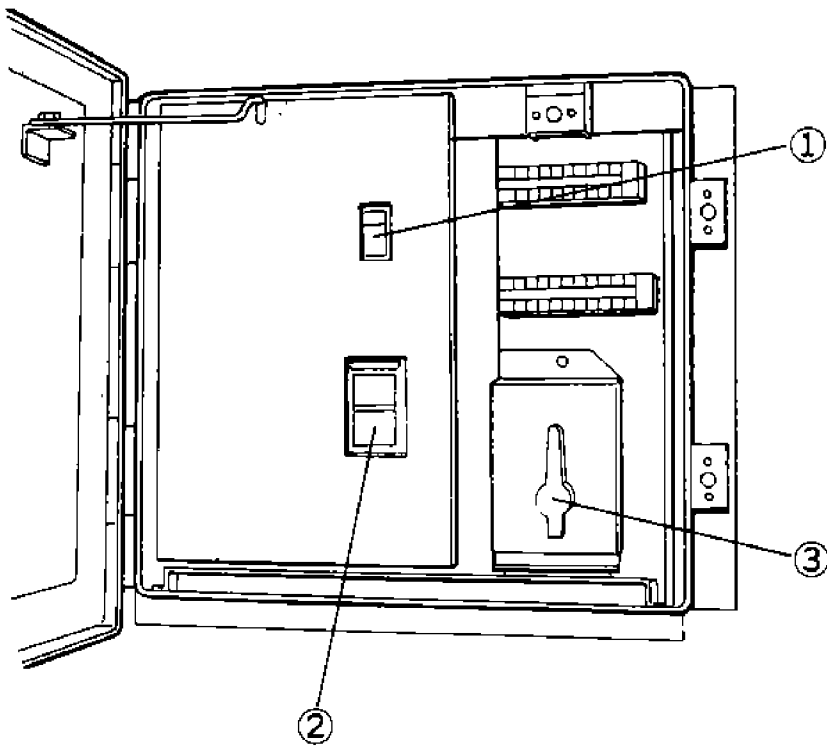

- | | |
|--|--|
| ① Circuit breaker (52C2) | ⑩ Auxiliary relays (49EFX1 · 2) |
| ② Circuit breaker (52C1) | ⑪ Phase sequence controller (47) |
| ③ Voltage selector switch (83) | ⑫ Magnetic contactors (47X1 · 2) |
| ④ Magnetic contactor for compressor (88C) | ⑬ Auxiliary relay (63WX) |
| ⑤ Magnetic contactors for high speed evaporator fan motor (88EFH1 · 2) | ⑭ Switch box thermostat (26BH) } Air/water cooled type |
| ⑥ Magnetic contactor for low speed evaporator fan motor (88EFL1 · 2) | |
| ⑦ Magnetic contactors for air cooled condenser fans (88CF1 · 2) | |
| ⑧ Over-current relay (51C) | |
| ⑨ Transformer (Tr2) | |

③ Switch box (Products before '89, 1)

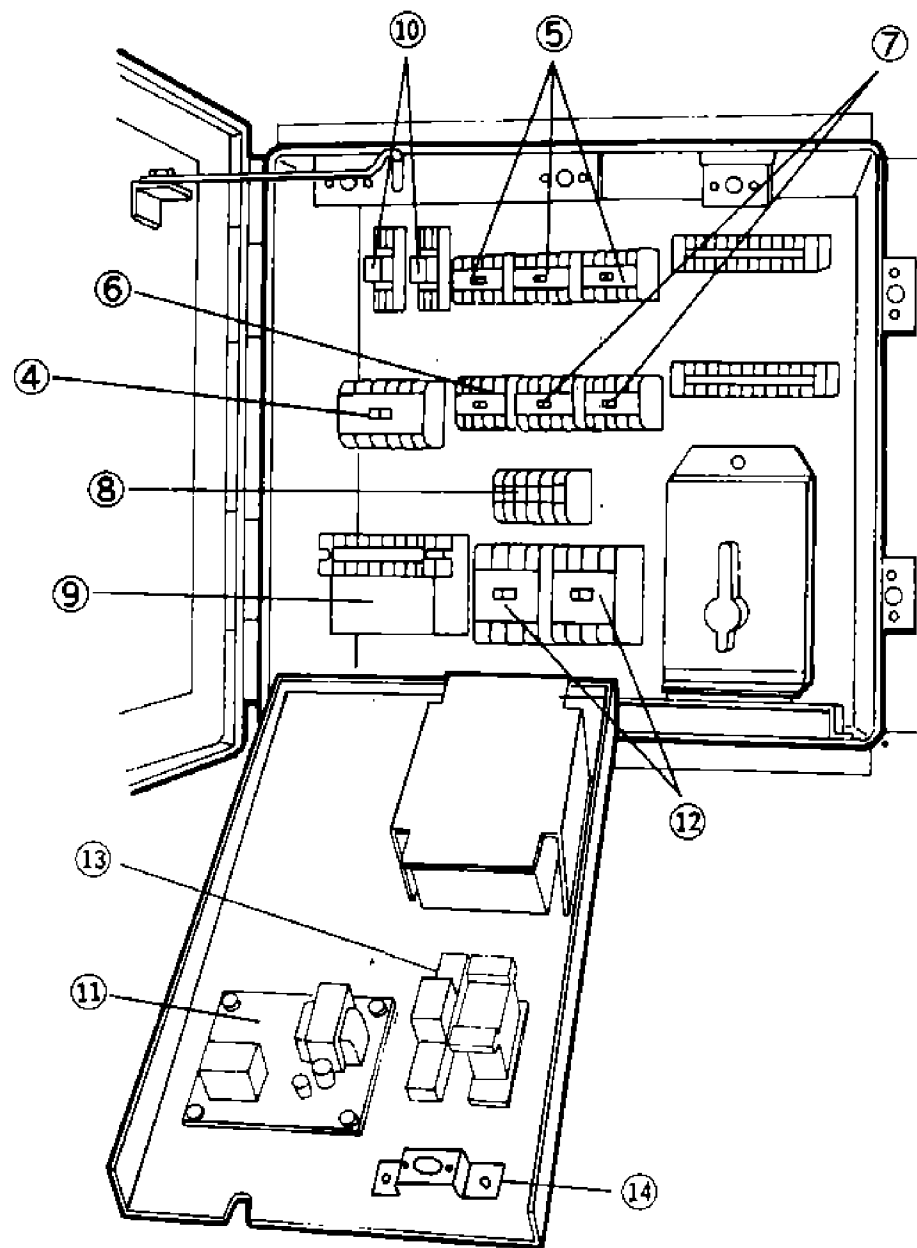
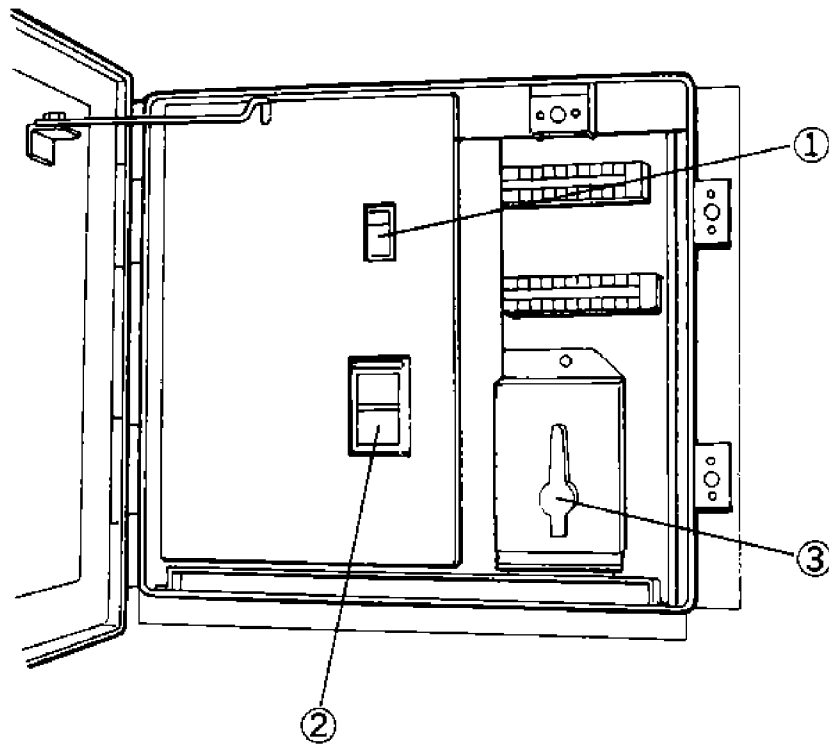

- | | |
|--|--|
| ① Circuit breaker (52C2) | ⑪ Phase sequence controller (47) |
| ② Circuit breaker (52C1) | ⑫ Magnetic contactors (47X1 · 2) |
| ③ Voltage selector switch (83) | ⑬ Auxiliary relay (63WX) |
| ④ Magnetic contactor for compressor (88C) | ⑭ Switch box thermostat (26BH) } Air/water cooled type |
| ⑤ Magnetic contactors for high speed evaporator fan motor (88EFH1 · 2 · 3) | |
| ⑥ Magnetic contactor for low speed evaporator fan motor (88EFL) | |
| ⑦ Magnetic contactors for air cooled condenser fans (88CF1 · 2) | |
| ⑧ Over-current relay (51C) | |
| ⑨ Transformer (Tr2) | |
| ⑩ Auxiliary relays (49EFX1 · 2) | |

1.2.4 Control box

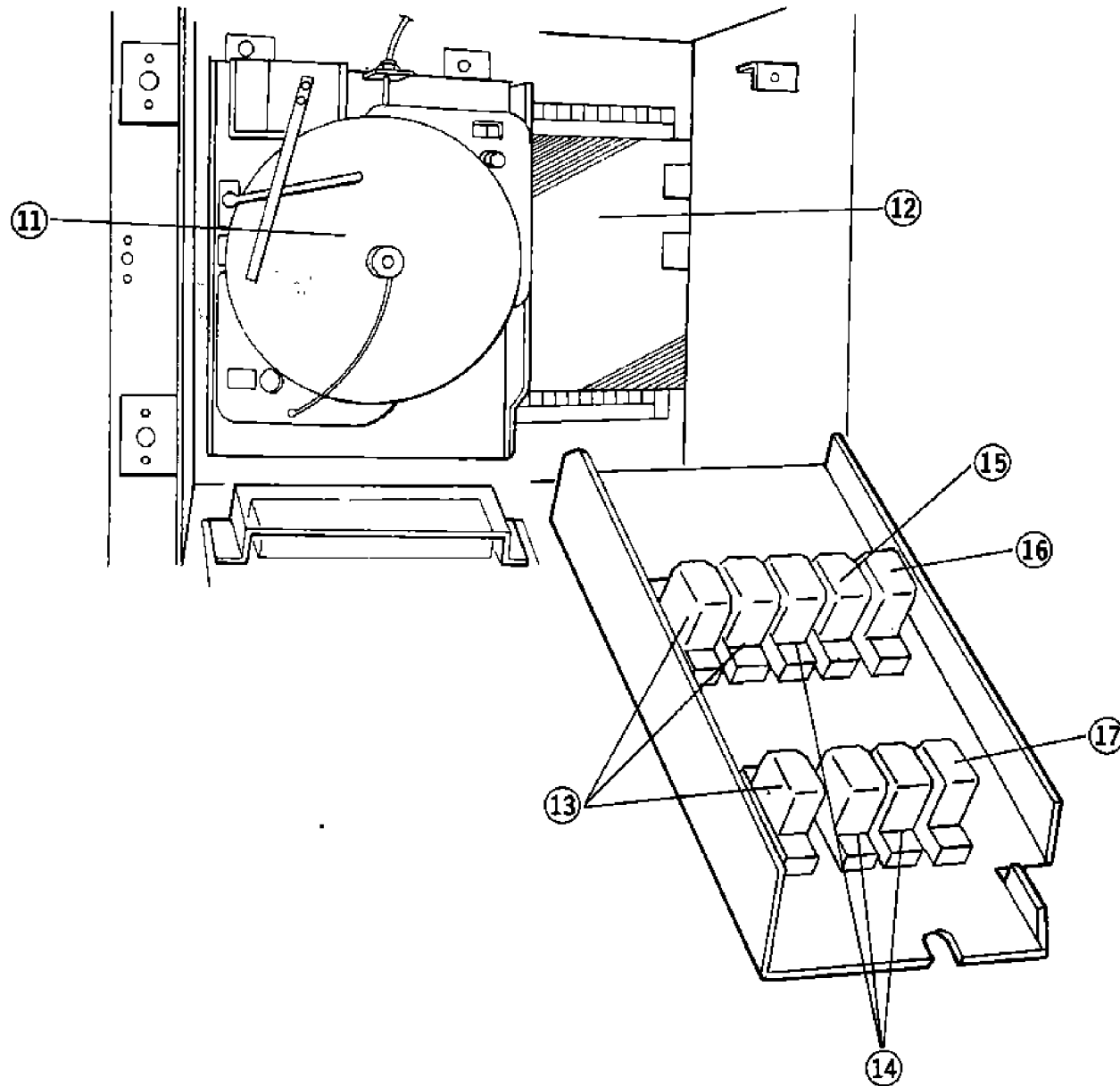
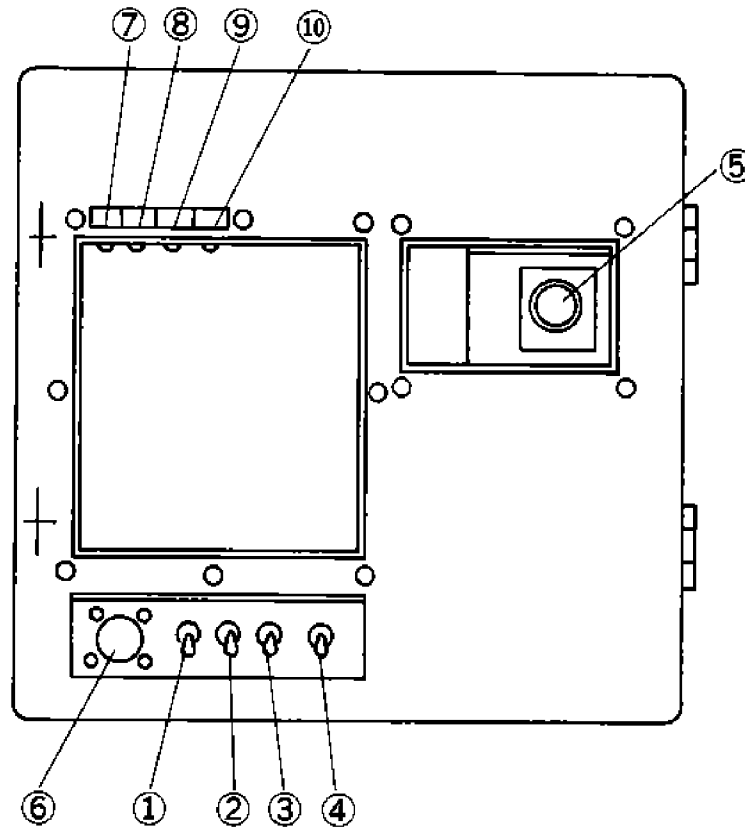

- ① Unit ON-OFF switch (3-88)
- ② AUTO-MANUAL defrost switch (3-D)
- ③ ON-OFF heat-up switch (3-H)
- ④ ON-OFF pilot lamp switch (3-30L)
- ⑤ Set point selector
- ⑥ Receptacle for monitoring
- ⑦ Pilot lamp (Red-DEFROST)(RL)
- ⑧ Pilot lamp (Green-COMP.)(GL)
- ⑨ Pilot lamp (Orange-IN RANGE)(OL)
- ⑩ Pilot lamp (White-POWER)(WL)
- ⑪ Recorder
- ⑫ Electronic controller (23A1 · 2)
- ⑬ Magnetic relays for defrost (2DX1 · 2 · 3)
- ⑭ Magnetic relays (3X1 · 2 · 3)
- ⑮ Magnetic relays for heat up (3HX)

- ⑯ Magnetic relay (88EFHX) ---(Products before '90, 10)
- ⑰ Magnetic relay (63LX)

1.3 Piping diagram

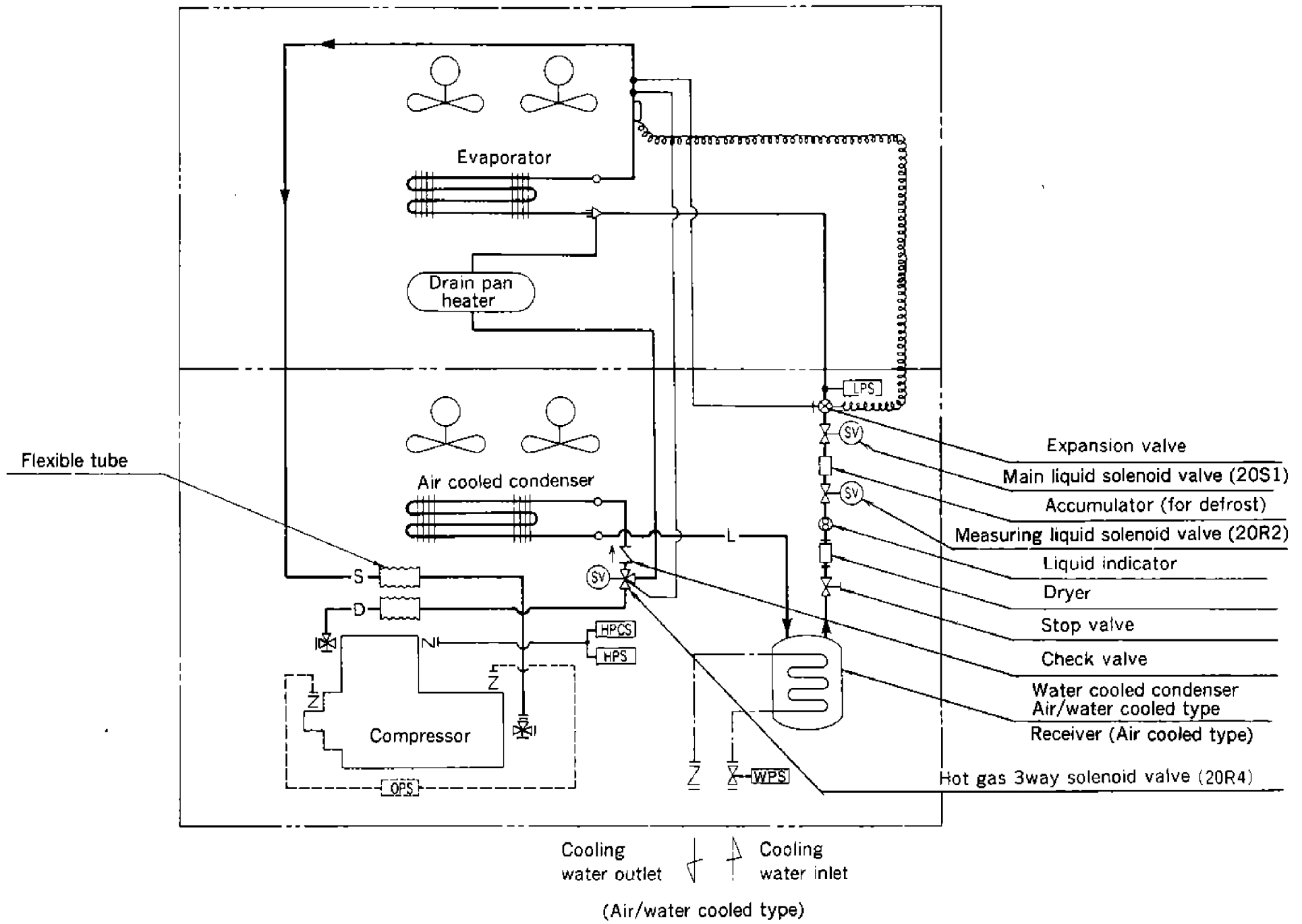

| | |
|-------------|---|
| HPS (63H1) | HIGH PRESSURE SWITCH |
| LPS (63L) | LOW PRESSURE SWITCH |
| HPCS (63H2) | HIGH PRESSURE CONTROL SWITCH |
| OPS (63QL) | OIL PRESSURE PROTECTION SWITCH (OPTION) |
| WPS (63W) | WATER PRESSURE SWITCH (Air/water cooled type) |

| | |
|-------|-------------------|
| — L — | LIQUID PIPE |
| — S — | SUCTION PIPE |
| — D — | DISCHARGE PIPE |
| — + — | FLANGE CONNECTION |
| — — | FLARE CONNECTION |
| — · — | WATER PIPE |

.....Shows optional specifications

1.4 Electric wiring diagrams
1.4.1 Sequence
(1) LXE5A-C (Products after '90, 11)
LXE5A-CT

CONTAINER REFRIGERATION UNIT
WIRING DIAGRAM

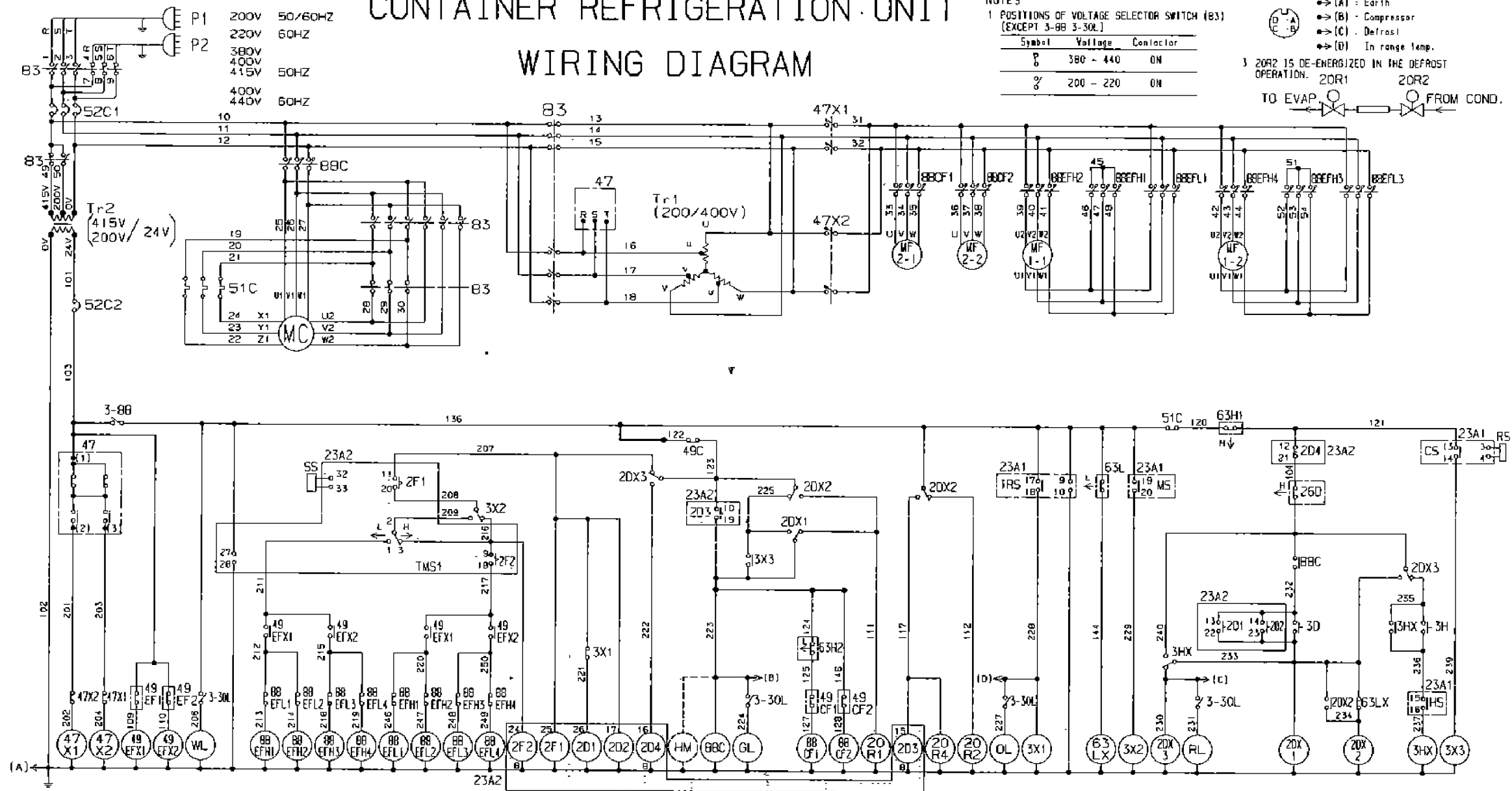

NOTES
1 POSITIONS OF VOLTAGE SELECTOR SWITCH (B3)
(EXCEPT 3-BB 3-30L)

| Symbol | Voltage | Contactor |
|--------|-----------|-----------|
| ⊕ | 380 - 440 | 0N |
| ⊘ | 200 - 220 | 0N |

2 MONITORING PLUG CONNECTED AS FOLLOWS.

- ⊕ (A) - Earth
- ⊙ (B) - Compressor
- ⊖ (C) - Defrost
- ⊕ (D) In range lamp.

3 2OR2 IS DE-ENERGIZED IN THE DEFFROST OPERATION. 2OR1 2OR2
TO EVAP. FROM COND.

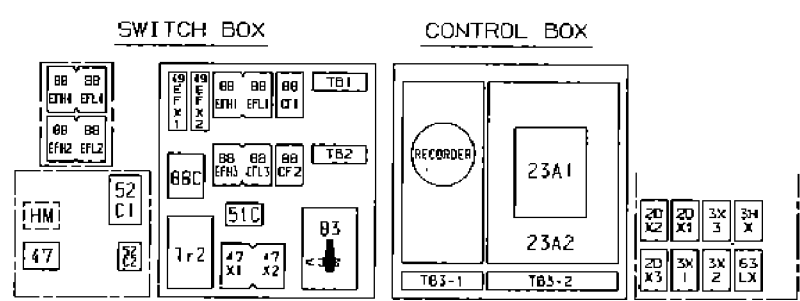

| | | | | | |
|--------|----------------------------------|----------|---------------------------|------|------------------------|
| 2D1 | TIME-LAG RELAY (4HOUR) | 49C | THERMO SWITCH (MC) | RL | LAMP (RED) |
| 2D2 | TIME-LAG RELAY (12HOUR) | 49CF1,2 | THERMO SWITCH (MF2) | R.S. | RETURN AIR SENSOR |
| 2D3 | TIME-LAG RELAY (20SEC.) | 49EF1,2 | THERMO SWITCH (MF1) | S.S. | SUPPLY AIR SENSOR |
| 2D4 | TIME-LAG RELAY (90MIN.) | 49EFX1,2 | MAGNETIC RELAY | Tr1 | TRANSFORMER (MF) |
| 2F1 | TIME-LAG RELAY (60SEC.) | 51C1,2 | OVER CURRENT RELAY (MC) | Tr2 | TRANSFORMER (CONTROL) |
| 2F2 | TIME-LAG RELAY (10SEC.) | 52C | CIRCUIT BREAKER | WL | LAMP (WHITE) |
| 2DX1-3 | MAGNETIC RELAY (DEFROST) | 63H1 | PRESSURE SWITCH (HIGH) | | |
| 3-BB | SWITCH (UNIT ON-OFF) | 63H2 | PRESSURE SWITCH (FAN CUT) | | |
| 3-30L | SWITCH (LAMP) | 63L | PRESSURE SWITCH (LOW) | | |
| 3D | SWITCH (MANUAL DEFROST) | 63LX | MAGNETIC RELAY | | |
| 3H | SWITCH (HEAT UP) | B3 | VOLTAGE SELECTOR SWITCH | | |
| 3HX | MAGNETIC RELAY (HEAT UP) | BBC | MAGNETIC CONTACTOR (MC) | | |
| 3X1-3 | MAGNETIC RELAY | BBCF1,2 | MAGNETIC CONTACTOR (MF2) | | |
| 2OR1 | SOLENOID VALVE (MAIN) | BBEFH1-4 | MAGNETIC CONTACTOR (MF1) | | |
| 2OR2 | SOLENOID VALVE (MEASURING) | BBEFL1-4 | MAGNETIC CONTACTOR (MF1) | | |
| 2OR4 | SOLENOID VALVE (3 WAY) | GL | LAMP (GREEN) | | |
| 23A1 | ELECTRONIC CONTROLLER | MC | MOTOR (COMPRESSOR) | | |
| 23A2 | ELECTRONIC CONTROLLER | MF1 | MOTOR (EVAP. FAN) | | |
| 26D | THERMO SWITCH (DEF. TERMINATION) | MF2 | MOTOR (COND. FAN) | | OPTIONAL SPECIFICATION |
| 47 | PHASE-REVERSAL RELAY | OL | LAMP (ORANGE) | HM | HOUR METER |
| 47X1,2 | MAGNETIC CONTACTOR | P1,2 | PLUG | | |

注意

1. 操作回路 (線番号 101 以降) には絶縁試験を行なわねこと。
2. ----- はオプション仕様を示す。
3. ●-● は短絡線を示す。

CAUTION

1. INSULATION TEST SHOULDN'T BE MADE TO CONTROL CIRCUIT (AFTER LINE NO.101)
2. ----- SHOWS OPTIONAL SPEC..
3. ●-● SHOWS JUMPER WIRE.

CONTAINER REFRIGERATION UNIT WIRING DIAGRAM

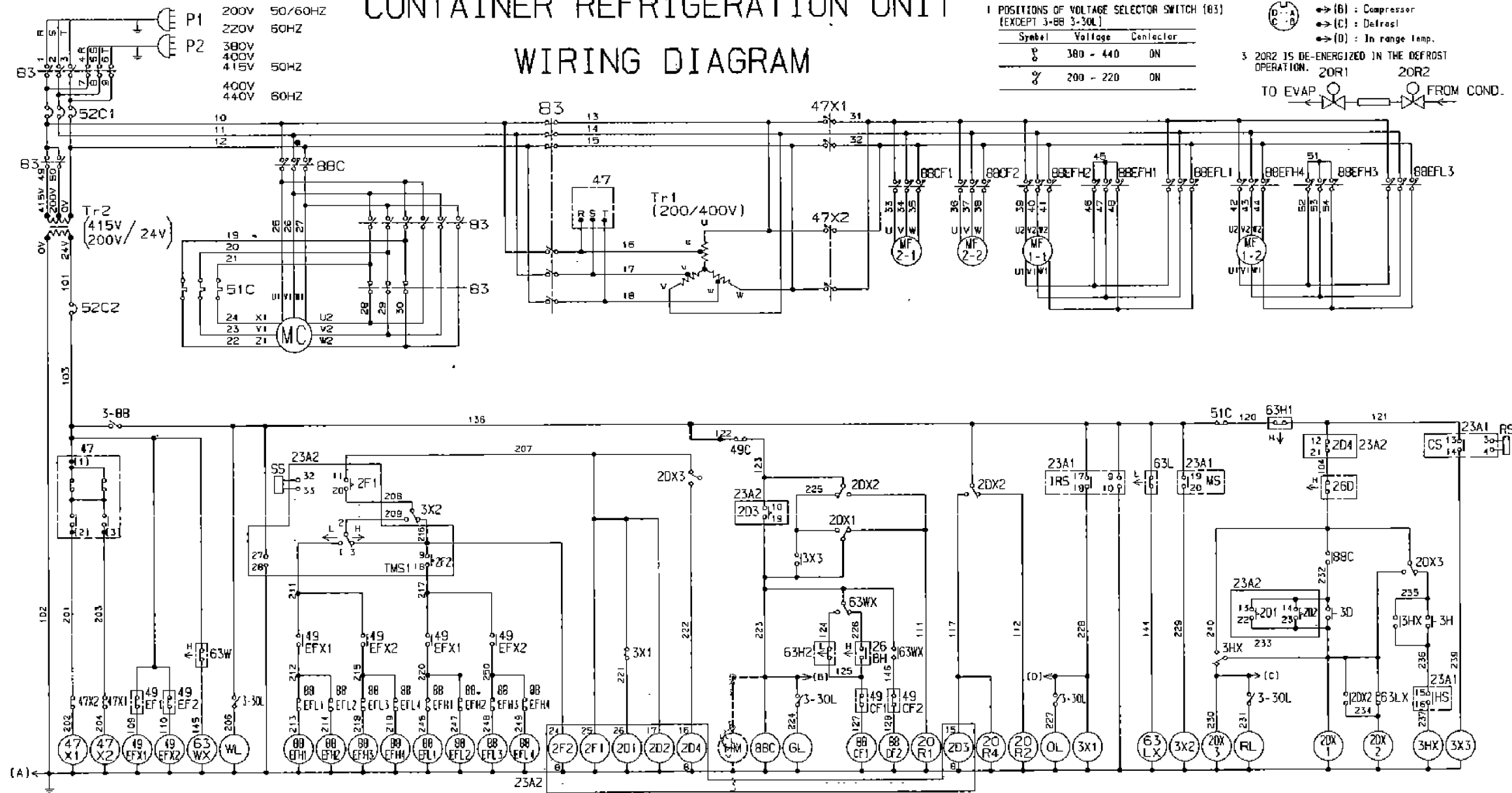

NOTES
1 POSITIONS OF VOLTAGE SELECTOR SWITCH (83)
(EXCEPT 3-8B 3-30L)

| Symbol | Voltage | Connector |
|--------|-----------|-----------|
| ⊘ | 380 - 440 | ON |
| ⊘ | 200 - 220 | ON |

2 MONITORING PLUG CONNECTED AS FOLLOWS.

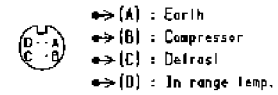

3 20R2 IS DE-ENERGIZED IN THE DEFROST OPERATION. 20R1 20R2
TO EVAP FROM COND.

(2) LXE5A-CA
LXE5A-CAT (Products before '90, 11)

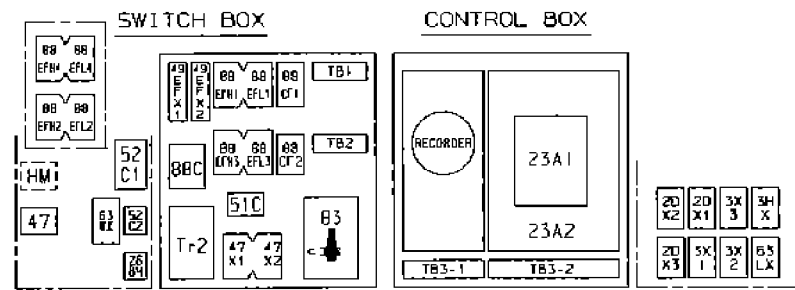

| | | | | | |
|--------|----------------------------------|----------|---------------------------|------|------------------------|
| 2D1 | TIME-LAG RELAY (4HOUR) | 47X1,2 | MAGNETIC CONTACTOR | MF2 | MOTOR (COND. FAN) |
| 2D2 | TIME-LAG RELAY (12HOUR) | 49C | THERMO SWITCH (MC) | OL | LAMP (ORANGE) |
| 2D3 | TIME-LAG RELAY (20SEC) | 49CF1,2 | THERMO SWITCH (MF2) | P1,2 | PLUG |
| 2D4 | TIME-LAG RELAY (90MIN.) | 49EF1,2 | THERMO SWITCH (MF1) | RL | LAMP (RED) |
| 2F1 | TIME-LAG RELAY (60SEC) | 49EFX1,2 | MAGNETIC RELAY | R.S. | RETURN AIR SENSOR |
| 2F2 | TIME-LAG RELAY (10SEC) | 51C1,2 | OVER CURRENT RELAY (MC) | S.S. | SUPPLY AIR SENSOR |
| 2DX1-3 | MAGNETIC RELAY (DEFROST) | 52C | CIRCUIT BREAKER | Tr-1 | TRANSFORMER (MF) |
| 3-8B | SWITCH (UNIT ON-OFF) | 63H1 | PRESSURE SWITCH (HIGH) | Tr-2 | TRANSFORMER (CONTROL) |
| 3-30L | SWITCH (LAMP) | 63H2 | PRESSURE SWITCH (FAN CUT) | WL | LAMP (WHITE) |
| 3D | SWITCH (MANUAL DEFROST) | 63L | PRESSURE SWITCH (LOW) | | |
| 3H | SWITCH (HEAT UP) | 63W | PRESSURE SWITCH (WATER) | | |
| 3HX | MAGNETIC RELAY (HEAT UP) | 63WX | MAGNETIC RELAY | | |
| 3X1-3 | MAGNETIC RELAY | 63LX | MAGNETIC RELAY | | |
| 20R1 | SOLENOID VALVE (MAIN) | 83 | VOLTAGE SELECTOR SWITCH | | |
| 20R2 | SOLENOID VALVE (MEASURING) | 8BC | MAGNETIC CONTACTOR (MC) | | |
| 20R4 | SOLENOID VALVE (3 WAY) | 8BCF1,2 | MAGNETIC CONTACTOR (MF2) | | |
| 23A1 | ELECTRONIC CONTROLLER | 8BEFL1-4 | MAGNETIC CONTACTOR (MF1) | | |
| 23A2 | ELECTRONIC CONTROLLER | 8BEFL1-4 | MAGNETIC CONTACTOR (MF1) | | |
| 26BH | THERMO SWITCH (SWITCH BOX) | 6L | LAMP (GREEN) | | OPTIONAL SPECIFICATION |
| 26D | THERMO SWITCH (DEF. TERMINATION) | MC | MOTOR (COMPRESSOR) | HW | HOURLY METER |
| 47 | PHASE-REVERSAL RELAY | MF1 | MOTOR (EVAP. FAN) | | |

注意
1. 操作回路 (線番号 101 以降) には絶縁試験を行なわぬこと。
2. -----はオプション仕様を示す。
3. ●---●は短絡線を示す。

CAUTION
1. INSULATION TEST SHOULDN'T BE MADE TO CONTROL CIRCUIT (AFTER LINE NO. 101).
2. -----SHOWS OPTIONAL SPEC..
3. ●---●SHOWS JUMPER WIRE.

CONTAINER REFRIGERATION UNIT WIRING DIAGRAM

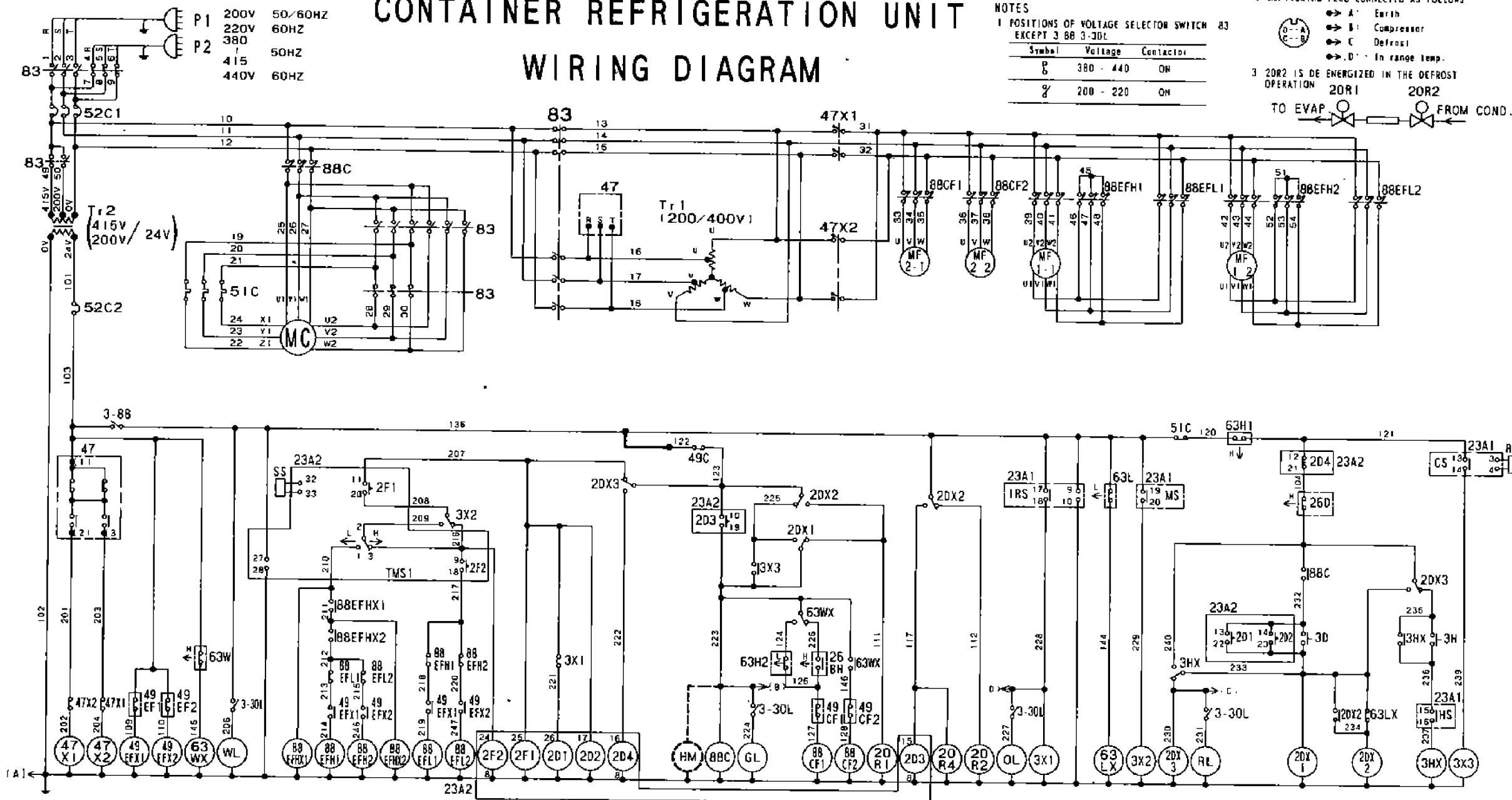

NOTES
1 POSITIONS OF VOLTAGE SELECTOR SWITCH 83 EXCEPT 3 BB 3-30L

| Symbol | Voltage | Contact |
|--------|-----------|---------|
| B | 380 - 440 | ON |
| W | 200 - 220 | ON |

2 MONITORING PLUG CONNECTED AS FOLLOWS

- A: Earth
- B: Compressor
- C: Defrost
- D: In range temp.

3 20R2 IS DE ENERGIZED IN THE DEFROST OPERATION

TO EVAP. FROM COND.

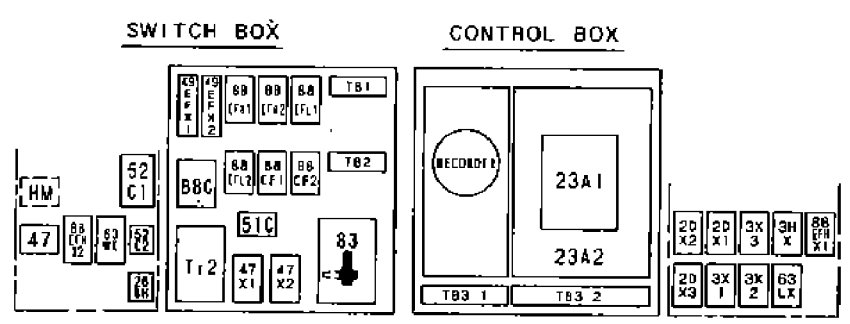

| | | | | | |
|--------|----------------------------------|-----------|---------------------------|------|------------------------|
| 2D1 | TIME-LAG RELAY (4HOUR) | 47X1.2 | MAGNETIC CONTACTOR | MF1 | MOTOR (EVAP. FAN) |
| 2D2 | TIME-LAG RELAY (12HOUR) | 49C | THERMO SWITCH (MC) | MF2 | MOTOR (COND. FAN) |
| 2D3 | TIME-LAG RELAY (20SEC.) | 49CF1.2 | THERMO SWITCH (MF2) | OL | LAMP (ORANGE) |
| 2D4 | TIME-LAG RELAY (90MIN.) | 49EF1.2 | THERMO SWITCH (MF1) | PI.2 | PLUG |
| 2F1 | TIME-LAG RELAY (60SEC.) | 49EFX1.2 | MAGNETIC RELAY | RL | LAMP (RED) |
| 2F2 | TIME-LAG RELAY (10SEC.) | 51C1.2 | OVER CURRENT RELAY (MC) | R.S. | RETURN AIR SENSOR |
| 2DX1-3 | MAGNETIC RELAY (DEFROST) | 52C | CIRCUIT BREAKER | S.S. | SUPPLY AIR SENSOR |
| 3 BB | SWITCH (UNIT ON-OFF) | 63H1 | PRESSURE SWITCH (HIGH) | Tr1 | TRANSFORMER (MF) |
| 3 30L | SWITCH (LAMP) | 63H2 | PRESSURE SWITCH (FAN CUT) | Tr2 | TRANSFORMER (CONTROL) |
| 3D | SWITCH (MANUAL DEFROST) | 63L | PRESSURE SWITCH (LOW) | WL | LAMP (WHITE) |
| 3H | SWITCH (HEAT UP) | 63W | PRESSURE SWITCH (WATER) | | |
| 3HX | MAGNETIC RELAY (HEAT UP) | 63WX | MAGNETIC RELAY | | |
| 3X1-3 | MAGNETIC RELAY | 63LX | MAGNETIC RELAY | | |
| 20R1 | SOLENOID VALVE (MAIN) | 83 | VOLTAGE SELECTOR SWITCH | | |
| 20R2 | SOLENOID VALVE (MEASURING) | 88C | MAGNETIC CONTACTOR (MC) | | |
| 20R4 | SOLENOID VALVE (3 WAY) | 88CF1.2 | MAGNETIC CONTACTOR (MF2) | | |
| 23A1 | ELECTRONIC CONTROLLER | 88EFH1.2 | MAGNETIC CONTACTOR (MF1) | | |
| 23A2 | ELECTRONIC CONTROLLER | 88EFHX1.2 | MAGNETIC RELAY | | |
| 268H | THERMO SWITCH (SWITCH BOX) | 88EFL1.2 | MAGNETIC CONTACTOR (MF1) | | OPTIONAL SPECIFICATION |
| 26D | THERMO SWITCH (DEF. TERMINATION) | GL | LAMP (GREEN) | HM | HOURLY METER |
| 47 | PHASE REVERSAL RELAY | MC | MOTOR (COMPRESSOR) | | |

注意

1. 操作回路 (線番号 101~) には絶縁試験を行なわぬこと。
2. ——— はオプション仕様を示す。
3. ——— は短絡線を示す。

CAUTION

1. INSULATION TEST SHOULDN'T BE MADE TO CONTROL CIRCUIT (LINE NO.101~).
2. ——— SHOWS OPTIONAL SPEC..
3. ——— SHOWS JUMPER WIRE.

(3) LXE5A-C (Products before '90, 10)
LXE5A-CT

CONTAINER REFRIGERATION UNIT WIRING DIAGRAM

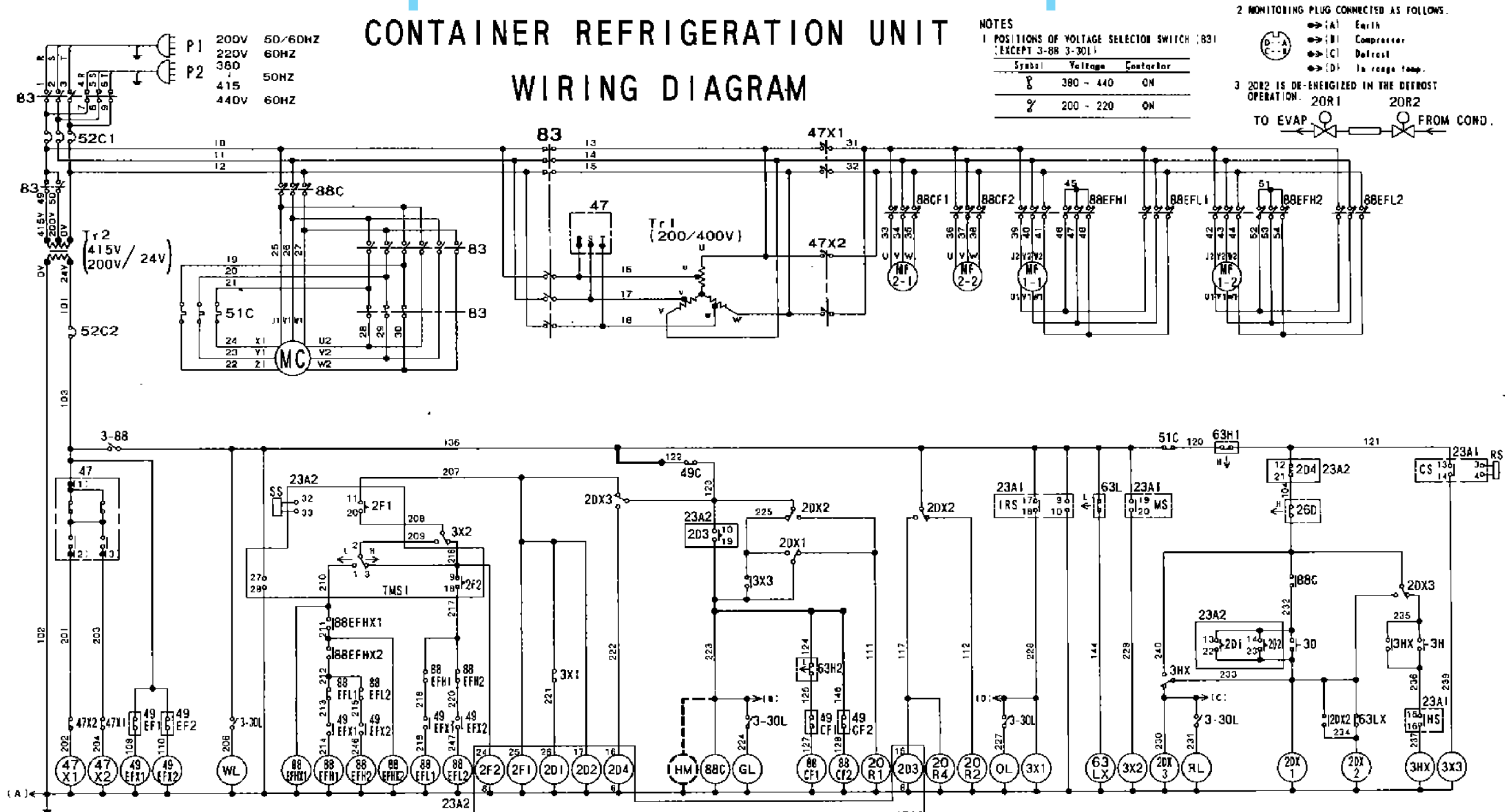

NOTES

1 POSITIONS OF VOLTAGE SELECTOR SWITCH (83) EXCEPT 3-88 3-30L1

| Symbol | Voltage | Contact |
|--------|-----------|---------|
| 8 | 380 - 440 | ON |
| 2 | 200 - 220 | ON |

- 2 MONITORING PLUG CONNECTED AS FOLLOWS.
- ⊕ (A) Earth
 - ⊕ (B) Compressor
 - ⊕ (C) Defrost
 - ⊕ (D) In range temp.
- 3 20R2 IS DE-ENERGIZED IN THE DEFROST OPERATION. 20R1 20R2
- TO EVAP. FROM COND.

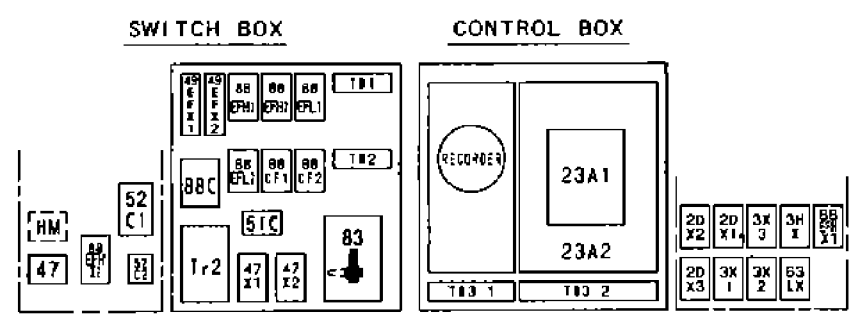

| | | | | | |
|--------|----------------------------------|-----------|---------------------------|------|------------------------|
| 2D1 | TIME-LAG RELAY (4HOUR) | 49C | THERMO SWITCH (MC) | P1.2 | PLUG |
| 2D2 | TIME-LAG RELAY (12HOUR) | 49CF1.2 | THERMO SWITCH (MF2) | RL | LAMP (RED) |
| 2D3 | TIME-LAG RELAY (20SEC.) | 49EF1.2 | THERMO SWITCH (MF1) | R.S. | RETURN AIR SENSOR |
| 2D4 | TIME-LAG RELAY (90MIN.) | 49EFX1.2 | MAGNETIC RELAY | S.S. | SUPPLY AIR SENSOR |
| 2F1 | TIME-LAG RELAY (60SEC.) | 51C1.2 | OVER CURRENT RELAY (MC) | Tr1 | TRANSFORMER (MF) |
| 2F2 | TIME-LAG RELAY (10SEC.) | 52C | CIRCUIT BREAKER | Tr2 | TRANSFORMER (CONTROL) |
| 2DX1-3 | MAGNETIC RELAY (DEFROST) | 63H1 | PRESSURE SWITCH (HIGH) | WL | LAMP (WHITE) |
| 3-88 | SWITCH (UNIT ON-OFF) | 63N2 | PRESSURE SWITCH (FAN CUT) | | |
| 3-30L | SWITCH (LAMP) | 63L | PRESSURE SWITCH (LOW) | | |
| 3D | SWITCH (MANUAL DEFROST) | 63LX | MAGNETIC RELAY | | |
| 3H | SWITCH (HEAT UP) | 83 | VOLTAGE SELECTOR SWITCH | | |
| 3HX | MAGNETIC RELAY (HEAT UP) | 88C | MAGNETIC CONTACTOR (MC) | | |
| 3X1-3 | MAGNETIC RELAY | 88CF1.2 | MAGNETIC CONTACTOR (MF2) | | |
| 20R1 | SOLENOID VALVE (MAIN) | 88EFH1.2 | MAGNETIC CONTACTOR (MF1) | | |
| 20R2 | SOLENOID VALVE (MEASURING) | 88EFHX1.2 | MAGNETIC RELAY | | |
| 20R4 | SOLENOID VALVE (3 WAY) | 88EFL1.2 | MAGNETIC CONTACTOR (MF1) | | |
| 23A1 | ELECTRONIC CONTROLLER | GL | LAMP (GREEN) | | |
| 23A2 | ELECTRONIC CONTROLLER | MC | MOTOR (COMPRESSOR) | | |
| 26D | THERMO SWITCH (DEF. TERMINATION) | MF1 | MOTOR (EVAP. FAN) | | OPTIONAL SPECIFICATION |
| 47 | PHASE-REVERSAL RELAY | MF2 | MOTOR (COND. FAN) | HM | HOUR METER |
| 47X1.2 | MAGNETIC CONTACTOR | OL | LAMP (ORANGE) | | |

- 注意
1. 操作回路 (線番号101~) には絶縁試験を行なわぬこと。
 2. -----はオプション仕様を示す。
 3. ●---は短絡線を示す。
- CAUTION
1. INSULATION TEST SHOULDN'T BE MADE TO CONTROL CIRCUIT (LINE NO.101~).
 2. -----SHOWS OPTIONAL SPEC..
 3. ●---SHOWS JUMPER WIRE.

(4) LXE5A-CA
LXE5A-CAT (Products before '90, 10)

CONTAINER REFRIGERATION UNIT WIRING DIAGRAM

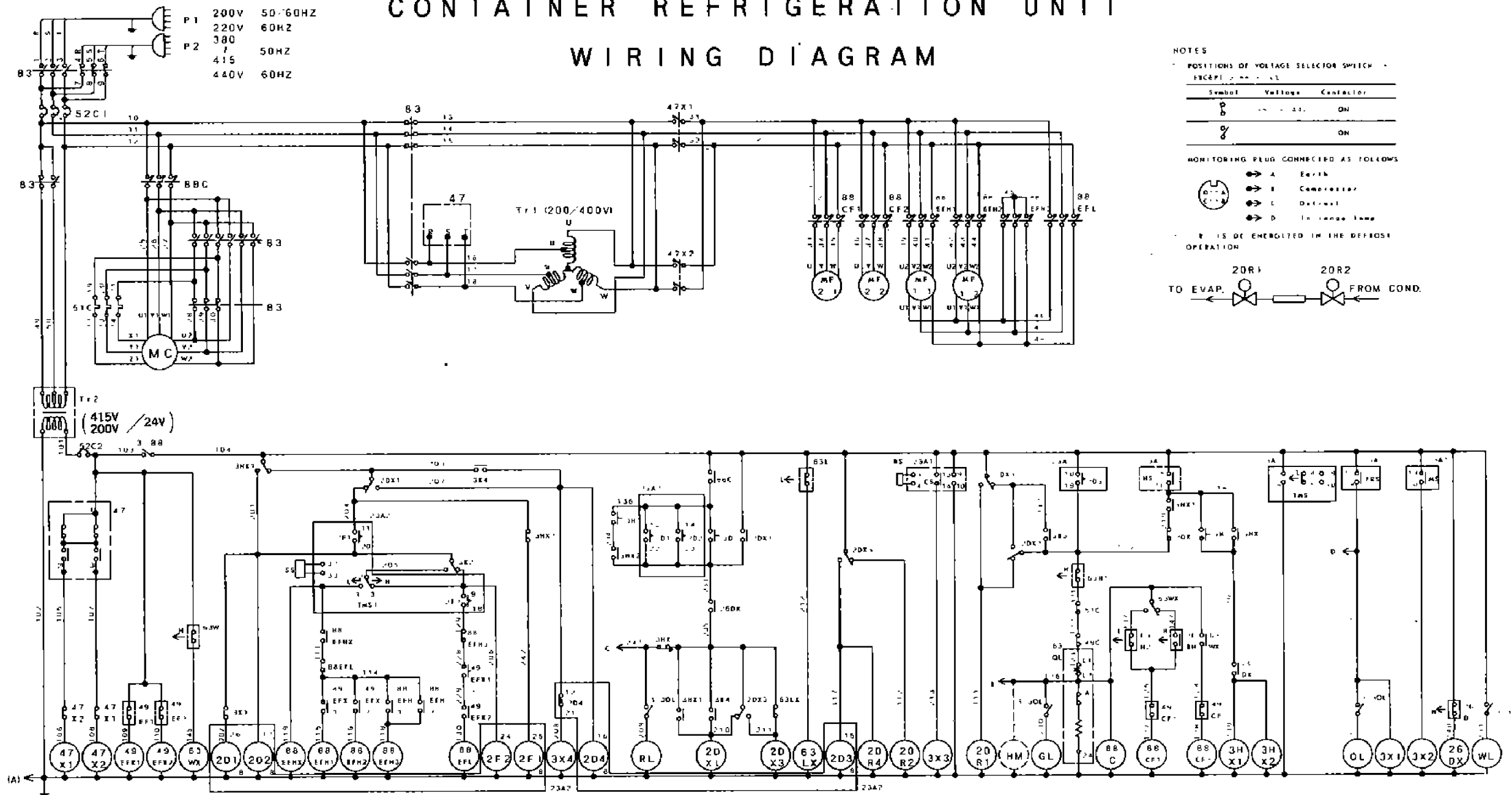

NOTES

POSITIONS OF VOLTAGE SELECTOR SWITCH - EXCEPT --- X1

| Symbol | Yellow | Contact |
|--------|--------|---------|
| | ON | ON |
| | ON | ON |

MONITORING PLUG CONNECTED AS FOLLOWS

| Symbol | Label |
|--------|-----------------|
| | A Earth |
| | B Compressor |
| | C Defrost |
| | D In range lamp |

R IS DE ENERGIZED IN THE DEFROST OPERATION

TO EVAP. 20R1 20R2 FROM COND.

(5) LXES-C (MFG. NO. 6700001~6800052)

22

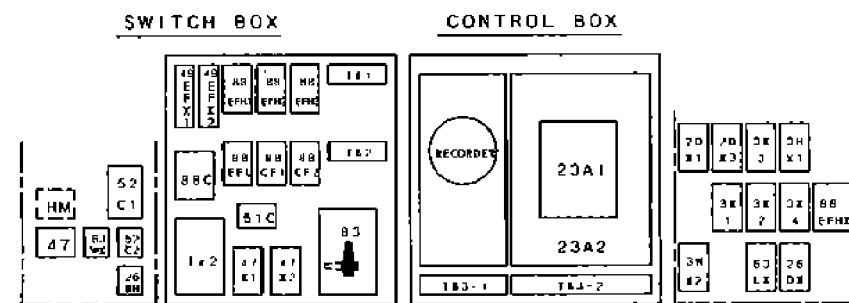

| | | | | | |
|-------|--------------------------|-------|--------------------------------|--------|------------------------|
| 2D1 | TIME LAG RELAY 4HOUR | 26DX | THERMO SWITCH DEF. TERMINATION | BBEFH | MAGNETIC CONTACTOR MF1 |
| 2D2 | TIME LAG RELAY 12HOUR | 26DX | MAGNETIC RELAY | BBEFHX | MAGNETIC RELAY |
| 2D3 | TIME-LAG RELAY 20SEC | 47 | PHASE-REVERSAL RELAY | BBEFL | MAGNETIC CONTACTOR MF1 |
| 2D4 | TIME-LAG RELAY 90MIN. | 47X | MAGNETIC CONTACTOR | GL | LAMP GREEN |
| 2F1 | TIME LAG RELAY 60SEC | 49C | THERMO SWITCH MC | OL | LAMP ORANGE |
| 2F2 | TIME-LAG RELAY 10SEC | 49CF | THERMO SWITCH MF2 | P | PLUG |
| 2DX1 | MAGNETIC RELAY DEFROST | 49EF | THERMO SWITCH MF1 | RL | LAMP RED |
| 2DX3 | MAGNETIC RELAY DEFROST | 49EFX | MAGNETIC RELAY | R.S. | RETURN AIR SENSOR |
| 3-BB | SWITCH UNIT ON-OFF | 51C | OVER CURRENT RELAY MC | S.S. | SUPPLY AIR SENSOR |
| 3-30L | SWITCH LAMP | 62C | CIRCUIT BREAKER | T.T.7 | TRANSFORMER MF |
| 3D | SWITCH MANUAL DEFROST | 63H1 | PRESSURE SWITCH HIGH | T.T.2 | TRANSFORMER CONTROL |
| 3H | SWITCH HEAT UP | 63H2 | PRESSURE SWITCH FAN CUT | WL | LAMP WHITE |
| 3X1-4 | MAGNETIC RELAY | 63L | PRESSURE SWITCH LOW | | |
| 3HX | MAGNETIC RELAY HEAT UP | 63LX | MAGNETIC RELAY | | |
| 20R1 | SOLENOID VALVE DEF. TRAP | 63QE | PRESSURE SWITCH OIL | | |
| 20R2 | SOLENOID VALVE DEF. TRAP | 63W | PRESSURE SWITCH WATER | | |
| 20R4 | SOLENOID VALVE 3 WAY | 63WX | MAGNETIC RELAY | | |
| 23A1 | ELECTRONIC CONTROLLER | B3 | VOLTAGE SELECTOR SWITCH | | OPTIONAL SPECIFICATION |
| 23A2 | ELECTRONIC CONTROLLER | BB | MAGNETIC CONTACTOR MC | HM | HOUR METER |
| 26BH | THERMO SWITCH SWITCH BOX | BBCF | MAGNETIC CONTACTOR MF2 | | |

注意

1. 操作回路 (線番号 101~) には絶縁試験を行なわぬこと。
2. -----はオプション仕様を示す。

CAUTION

1. INSULATION TEST SHOULDN'T BE MADE TO CONTROL CIRCUIT (LINE NO. 101~).
2. ----- SHOWS OPTIONAL SPEC.

CONTAINER REFRIGERATION UNIT WIRING DIAGRAM

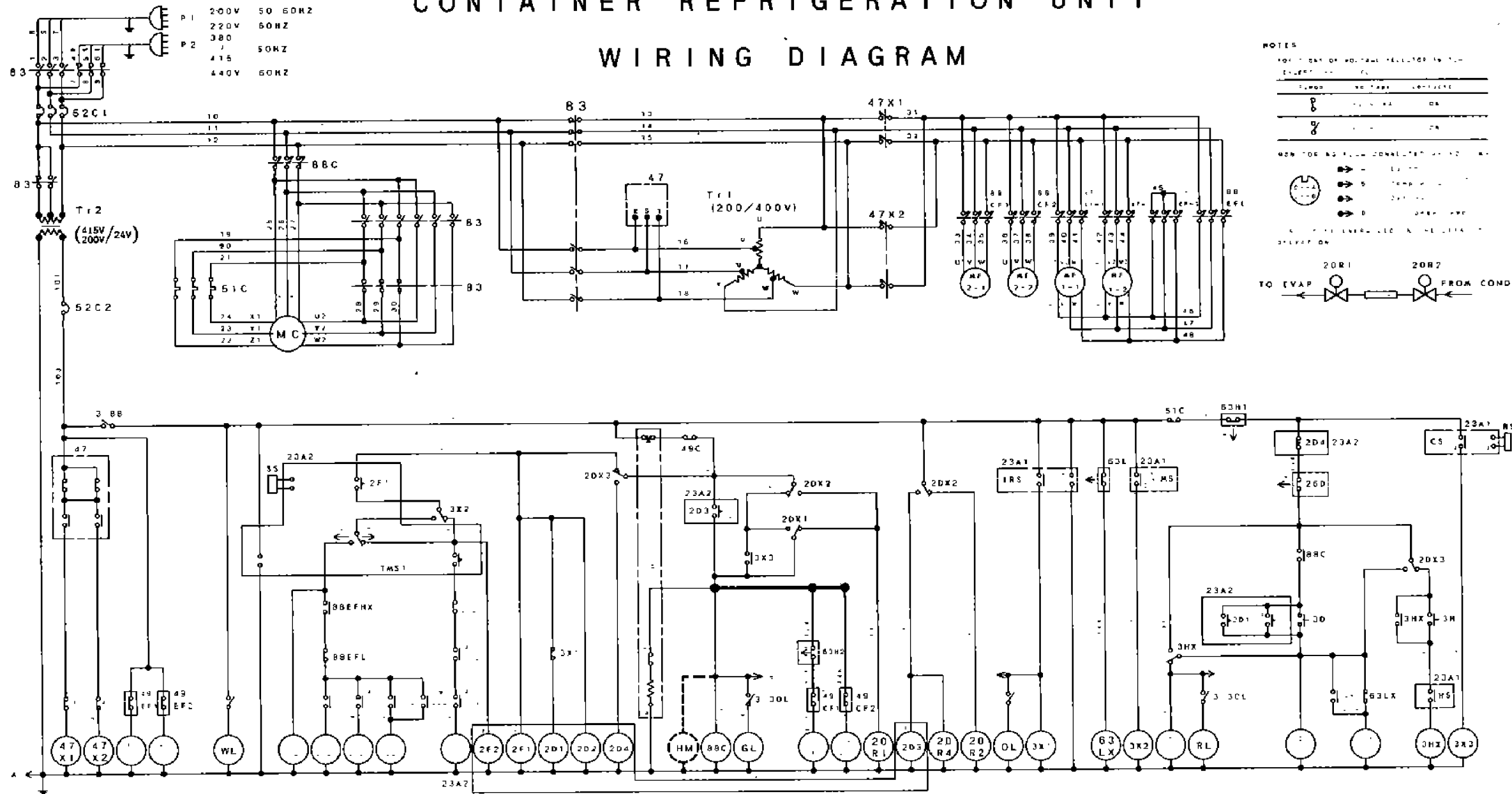

NOTES

1. FOR THE USE OF VOLTA-GE SELECTOR SW. (LINE NO. 101~104)

2. FOR THE USE OF FULL CONDUCTOR (LINE NO. 105~108)

3. ALL WIRING SHOULD BE MADE IN ACCORDANCE WITH THE LOCAL ELECTRICAL CODE.

TO EVAP FROM COND

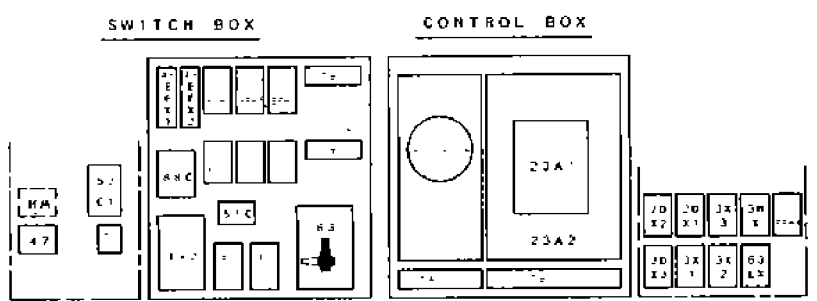

| | | | | | |
|---------|-----------------------------|----------|--------------------------|-------|------------------------|
| 2D1 | TIME LAG RELAY 1 HOUR | 49C | THERMO SWITCH AC | DL | LAMP ORANGE |
| 2D2 | TIME LAG RELAY 17 HOUR | 49CF1, 2 | THERMO SWITCH A12 | P1, 2 | PLUG |
| 2D3 | TIME LAG RELAY 20 SEC | 49CF1, 2 | THERMO SWITCH AF1 | WL | LAMP RED |
| 2D4 | TIME LAG RELAY 90 MIN | 49CF1, 2 | MAGNETIC RELAY | 3, 5 | RETURN AIR SENSOR |
| 2F1 | TIME LAG RELAY 60 SEC | 5TC | OVER CURRENT RELAY AC | 3, 5 | SUPPLY AIR SENSOR |
| 2F2 | TIME LAG RELAY 10 SEC | 52C1, 2 | CIRCUIT BREAKER | 1, 1 | TRANSFORMER AF |
| 2D1~3 | MAGNETIC RELAY DEFROST | 63H1 | PRESSURE SWITCH HIGH | 1, 2 | TRANSFORMER CONTROL |
| 2, 56 | SWITCH UNIT ON-OFF | 63H2 | PRESSURE SWITCH FAN CU3 | WE | LAMP WHITE |
| 2-30L | SWITCH LAMP | 63L | PRESSURE SWITCH LOW | | |
| 3D | SWITCH MANUAL DEFROST | 63Q1 | PRESSURE SWITCH OIL | | |
| 3H | SWITCH HEAT UP | 63IX | MAGNETIC RELAY | | |
| 3HX | MAGNETIC RELAY HEAT UP | 83 | VOLTAGE SELECTION SWITCH | | |
| 3X1~3 | MAGNETIC RELAY | 88C | MAGNETIC CONTACTOR AC | | |
| 20R1 | TEMPERATURE SENSING RELAY | 88CF1, 2 | MAGNETIC CONTACTOR HF2 | | |
| 20R2 | TEMPERATURE SENSING RELAY | 88CF1~3 | MAGNETIC CONTACTOR HF1 | | |
| 20R4 | TEMPERATURE SENSING RELAY | 88EFX | MAGNETIC RELAY | | |
| 23A1 | ELECTRONIC CONTROLLER | 88EFL | MAGNETIC CONTACTOR AF1 | | |
| 23A2 | ELECTRONIC CONTROLLER | GL | LAMP GREEN | | |
| 47D | THERMO SWITCH DEFERMINATION | MC | MOTOR COMPRESSOR | | OPTIONAL SPECIFICATION |
| 47 | PHASE-REVERSAL RELAY | AF1 | MOTOR EVAP FAN | WA | HOUR METER |
| 47X1, 2 | MAGNETIC CONTACTOR | AF2 | MOTOR COND FAN | | |

注意

1. 操作回路 (線番号 101~) には絶縁試験を行なわぬこと。
2. ----- はオプション仕様を示す。
3. ●●● は短絡線を示す。

CAUTION

1. INSULATION TEST SHOULD NOT BE MADE TO CONTROL CIRCUIT LINE NO. 101~
2. ----- SHOWS OPTIONAL SPEC.
3. ●●● SHOWS JUMPER WIRE

(6) LXES-CA
LXES-CAT (MFG. NO. 6800026 ~)

CONTAINER REFRIGERATION UNIT WIRING DIAGRAM

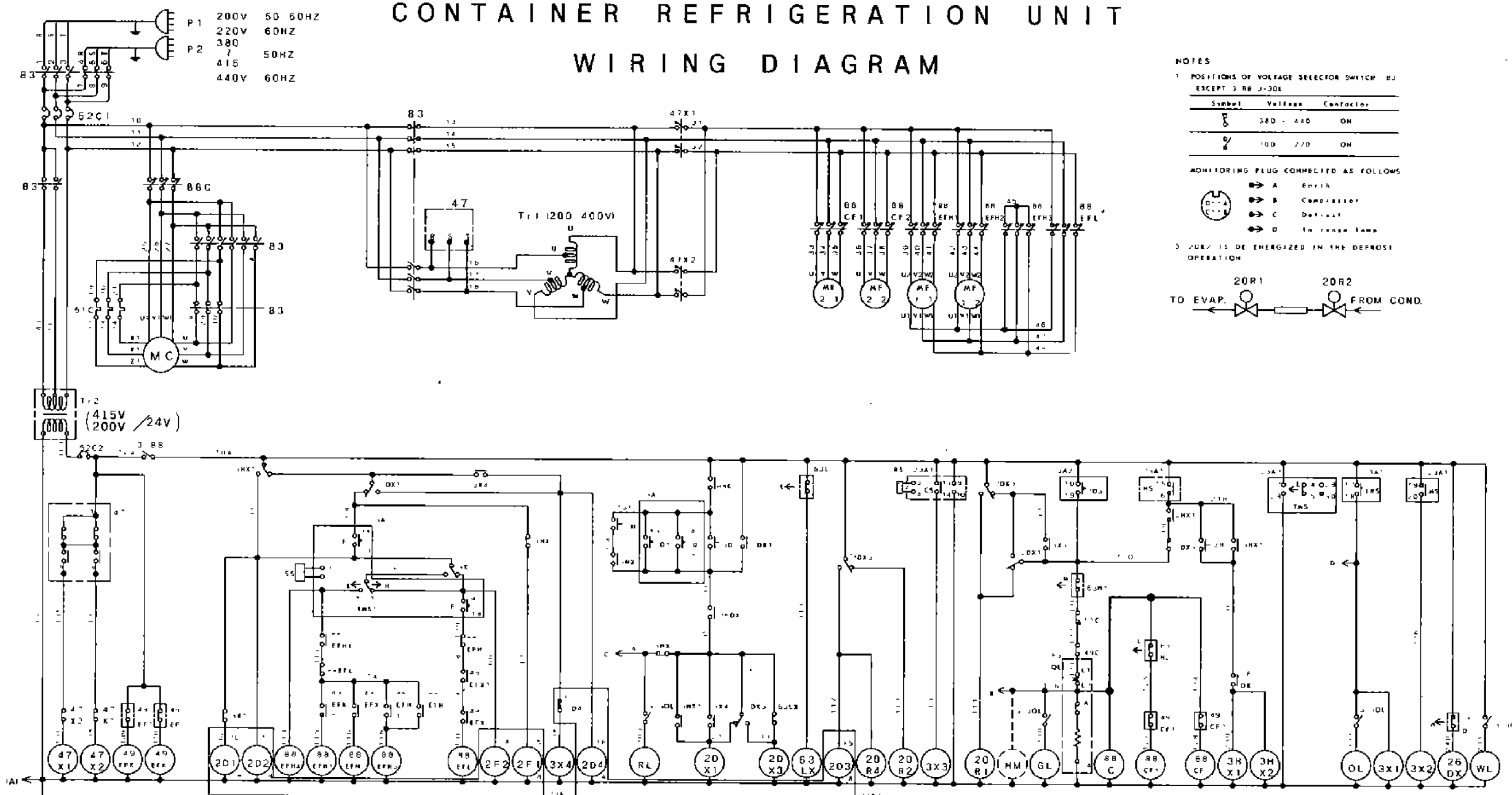

NOTES
 1. POSITIONS OF VOLTAGE SELECTOR SWITCH 52 EXCEPT 3 RR J-30L

| Symbol | Voltage | Contactors |
|--------|-----------|------------|
| | 380 - 440 | ON |
| | 100 - 270 | ON |

MONITORING PLUG CONNECTED AS FOLLOWS

| Terminal | Function |
|----------|-------------|
| A | Evap. |
| B | Compressor |
| C | Defrost |
| D | Evap. Temp. |

3. JUB/ IS ENERGIZED IN THE DEFROST OPERATION

 20R1 TO EVAP.
 20R2 FROM COND.

(7) LXES-CAT-① (MFG. NO. 6700001~6700025)
 (Note : Wiring differs with the refrigeration units)

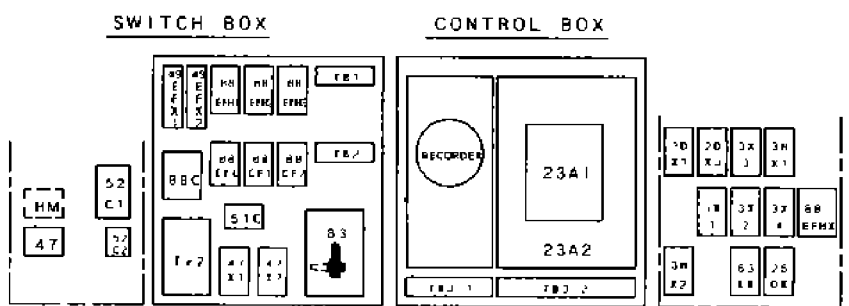

| | | | | | |
|-------|-------------------------------|--------|-------------------------|------------------------|---------------------|
| 2D1 | TIME LAG RELAY 4HOUR | 26DX | MAGNETIC RELAY | GL | LAMP GREEN |
| 2D2 | TIME LAG RELAY 12HOUR | 47 | PHASE REVERSAL RELAY | OL | LAMP ORANGE |
| 2D3 | TIME LAG RELAY 20SEC | 47X | MAGNETIC CONTACTOR | P | PLUG |
| 2D4 | TIME LAG RELAY 30MIN. | 83C | THERMO SWITCH MC | RL | LAMP RED |
| 2F1 | TIME LAG RELAY 60SEC. | 48CF | THERMO SWITCH MF2 | R S. | RETURN AIR SENSOR |
| 2F2 | TIME LAG RELAY 10SEC | 49EF | THERMO SWITCH MF1 | S S. | SUPPLY AIR SENSOR |
| 2DX1 | MAGNETIC RELAY DEFROST | 49EFX | MAGNETIC RELAY | T:1 | TRANSFORMER MF |
| 2DX2 | MAGNETIC RELAY DEFROST | 51C | OVER CURRENT RELAY MC | T:2 | TRANSFORMER CONTROL |
| 3 83 | SWITCH UNIT ON OFF | 52C | CIRCUIT BREAKER | WL | LAMP WHITE |
| 3 JOL | SWITCH LAMP | 63H1 | PRESSURE SWITCH HIGH | | |
| JD | SWITCH MANUAL DEFROST | 63H2 | PRESSURE SWITCH FAN CUT | | |
| 3H | SWITCH HEAT UP | 63L | PRESSURE SWITCH LOW | | |
| 3E~4 | MAGNETIC RELAY | 63LX | MAGNETIC RELAY | | |
| 3HX | MAGNETIC RELAY HEAT UP | 63OL | PRESSURE SWITCH OIL | | |
| 20R1 | SOLENOID VALVE DEF TRAP1 | 83 | VOLTAGE SELECTOR SWITCH | | |
| 20R2 | SOLENOID VALVE DEF TRAP2 | 88C | MAGNETIC CONTACTOR MC | | |
| 20R4 | SOLENOID VALVE 3 WAY | 88CF | MAGNETIC CONTACTOR MF2 | | |
| 23A1 | ELECTRONIC CONTROLLER | 88EFH | MAGNETIC CONTACTOR MF1 | OPTIONAL SPECIFICATION | |
| 23A2 | ELECTRONIC CONTROLLER | 88EFHX | MAGNETIC RELAY | HM | HOUR METER |
| 26D | THERMO SWITCH DEF TERMINATION | 88EFL | MAGNETIC CONTACTOR MF1 | | |

注意

1. 操作回路 (線番号 101~) には絶縁試験を行なわぬこと。
2. -----はオプション仕様を示す。
3. ●---●は短絡線を示す。

CAUTION

1. INSULATION TEST SHOULDN'T BE MADE TO CONTROL CIRCUIT (LINE NO. 101~)
2. ----- SHOWS OPTIONAL SPEC.
3. ●---● SHOWS JUMPER WIRE.

(8) LXES-CAT-2 (MFG. NO. 6700001~6700025)
 (Note: Wiring differs with the refrigeration units)

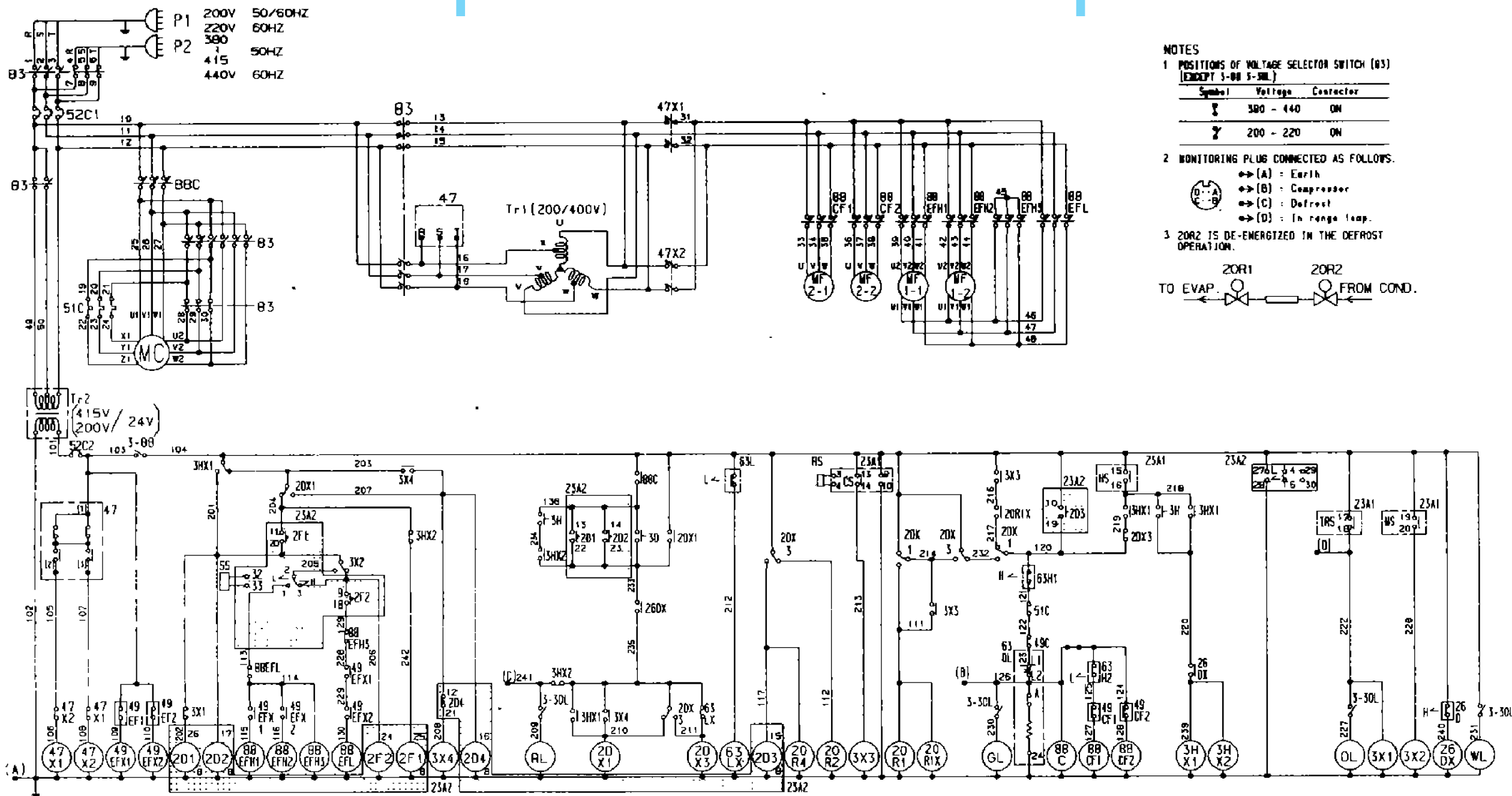

NOTES
 1 POSITIONS OF VOLTAGE SELECTOR SWITCH (83)
 (EXCEPT 3-BB S-SM)

| Symbol | Voltage | Contactor |
|--------|-----------|-----------|
| ⚡ | 380 - 440 | ON |
| ⚡ | 200 - 220 | ON |

2 MONITORING PLUS CONNECTED AS FOLLOWS.

- (A) : Earth
- (B) : Compressor
- (C) : Defrost
- (D) : In range lamp.

3 20R2 IS DE-ENERGIZED IN THE DEFROST OPERATION.

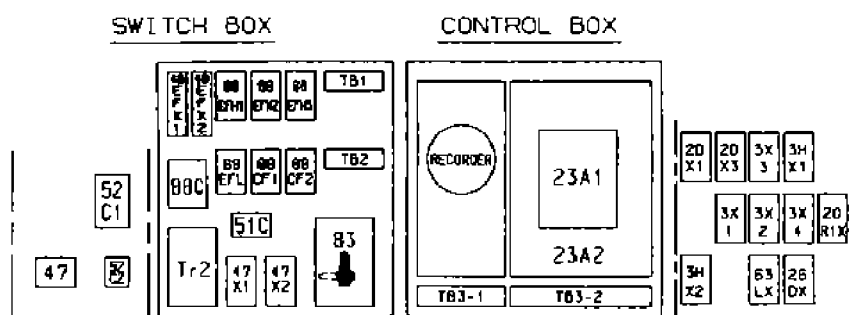

| | | | | | |
|-------|-----------------------------|-------|----------------------------------|-------|--------------------------|
| 2D1 | TIME-LAG RELAY (4HOUR) | 23A1 | ELECTRONIC CONTROLLER | 8BEFH | MAGNETIC CONTACTOR (WF1) |
| 2D2 | TIME-LAG RELAY (12HOUR) | 23A2 | ELECTRONIC CONTROLLER | 8BEFL | MAGNETIC CONTACTOR (WF1) |
| 2D3 | TIME-LAG RELAY (20SEC.) | 26D | THERMO SWITCH (DEF. TERMINATION) | GL | LAMP (GREEN) |
| 2D4 | TIME-LAG RELAY (90MIN.) | 26DX | MAGNETIC RELAY | DL | LAMP (ORANGE) |
| 2F1 | TIME-LAG RELAY (60SEC.) | 47 | PHASE-REVERSAL RELAY | P | PLUG |
| 2F2 | TIME-LAG RELAY (10SEC.) | 47X | MAGNETIC CONTACTOR | RL | LAMP (RED) |
| 2DX1 | MAGNETIC RELAY (DEFROST) | 49C | THERMO SWITCH (WC) | R.S. | RETURN AIR SENSOR |
| | | 49CF | THERMO SWITCH (WF2) | S.S. | SUPPLY AIR SENSOR |
| 2DX3 | MAGNETIC RELAY (DEFROST) | 49EF | THERMO SWITCH (WF1) | Tr1 | TRANSFORMER (WF) |
| 3-BB | SWITCH (UNIT ON-OFF) | 49EFX | MAGNETIC RELAY | Tr2 | TRANSFORMER (CONTROL) |
| 3-30L | SWITCH (LAMP) | 51C | OVER CURRENT RELAY (WC) | WL | LAMP (WHITE) |
| 3D | SWITCH (MANUAL DEFROST) | 52C | CIRCUIT BREAKER | | |
| 3H | SWITCH (HEAT UP) | 63H1 | PRESSURE SWITCH (HIGH) | | |
| 3X1-4 | MAGNETIC RELAY | 63H2 | PRESSURE SWITCH (FAN CUT) | | |
| 3HX | MAGNETIC RELAY (HEAT UP) | 63L | PRESSURE SWITCH (LOW) | | |
| 20R1 | SOLENOID VALVE (DEF. TRAP1) | 63LX | PRESSURE SWITCH (OIL) | | |
| 20R1X | MAGNETIC RELAY | 63LX | MAGNETIC RELAY | | |
| 20R2 | SOLENOID VALVE (DEF. TRAP2) | 83 | VOLTAGE SELECTOR SWITCH | | |
| | | 8BC | MAGNETIC CONTACTOR (WC) | | |
| 20R4 | SOLENOID VALVE (3 WAY) | 8BCF | MAGNETIC CONTACTOR (WF2) | | |

注意

操作回路 (線番号
101~) には絶縁
試験を行なわぬこと。

CAUTION

INSULATION TEST
SHOULDN'T BE MADE
TO CONTROL CIR-
CUIT (LINE NO.
101 ~).

1.4.2 Actual wiring diagram

- (1) LXE5A-C
- LXE5A-CT
- LXE5A-CA
- LXE5A-CAT

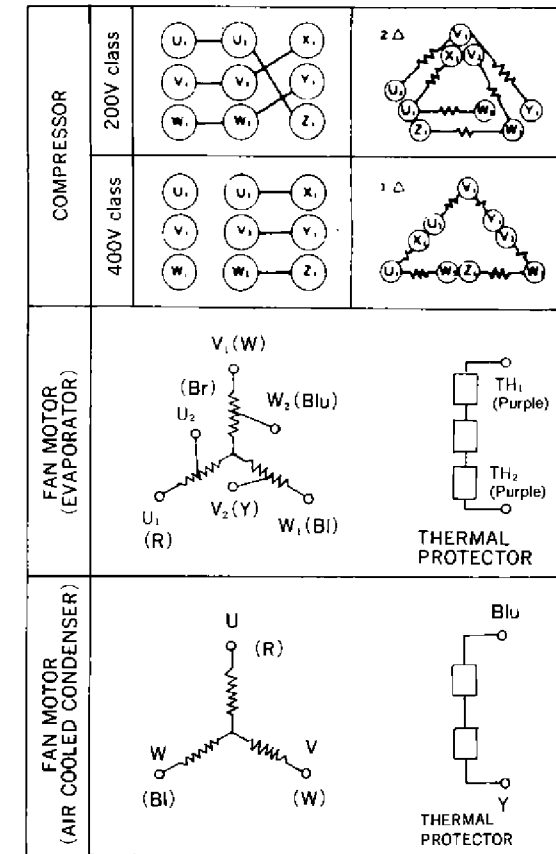
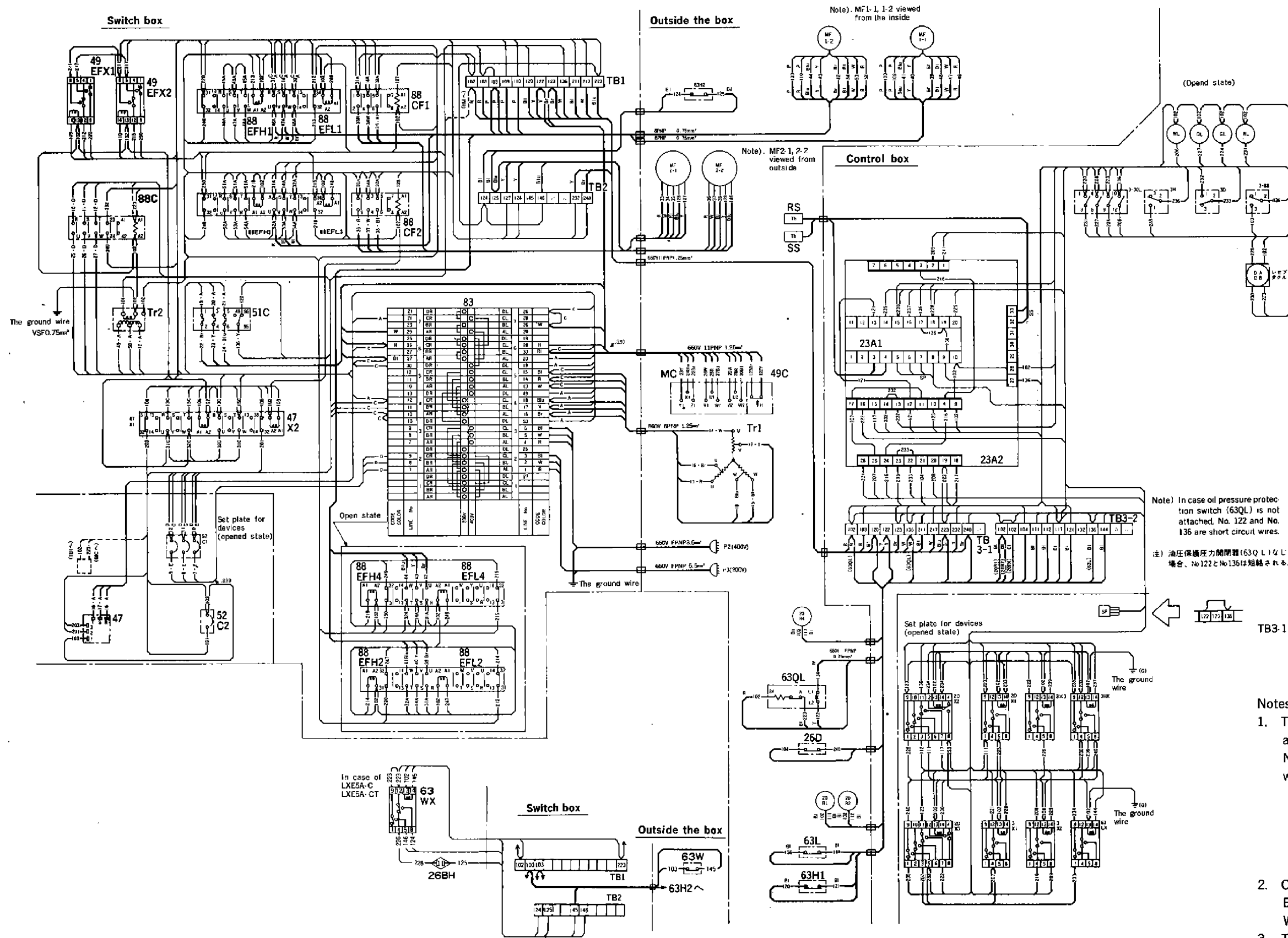

Note: In case of pressure protection switch (63QL) is not attached, No. 122 and No. 136 are short circuit wires.
 注) 油圧保護圧力開閉器(63QL)なしの場合、No.122とNo.136は短絡される。

- Notes:
- Terminal numbers in each component and wiring used are as shown below.
 Numbers of wiring 101 ~ :
 100V KIV 0.75mm² :
 660V SYP 1.25mm² : —A—
 660V SYP 2.0mm² : —B—
 660V SYP 3.5mm² : —C—
 660V SYP 5.5mm² : —D—
 660V SYP 0.75mm² :
 - Colors of wiring
 Bl : Black Blu : Blue Br : Brown R : Red Y : Yellow W : White (G) : Green (for earth)
 - The ground wire is VSF 0.75mm².
 -shows the optional parts.

(2) LXE5A-C
LXE5A-CT
LXE5A-CA
LXE5A-CAT
(Products before '90.10)

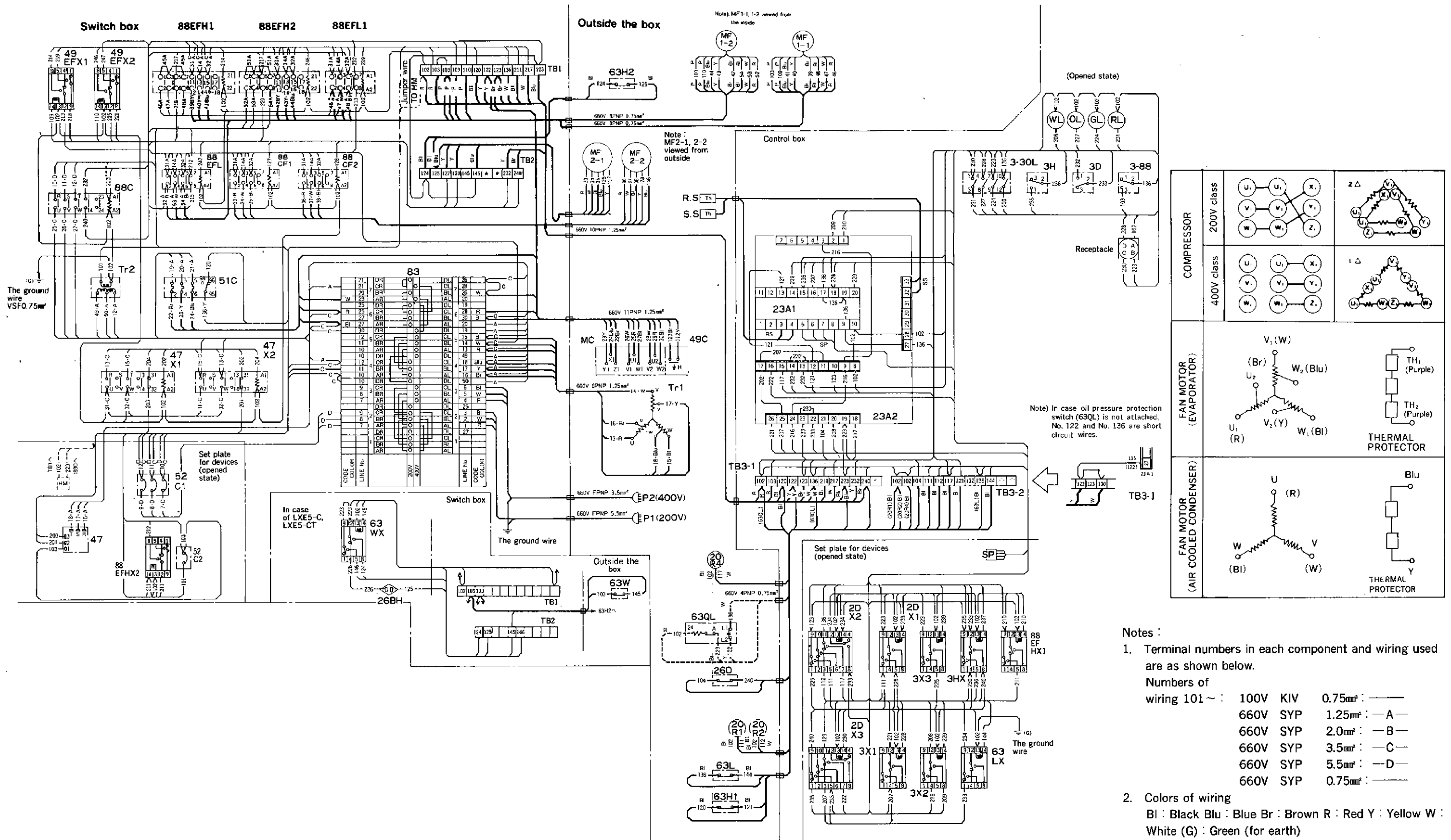

- Notes:
- Terminal numbers in each component and wiring used are as shown below.
Numbers of wiring 101~: 100V KIV 0.75mm²: —
660V SYP 1.25mm²: —A—
660V SYP 2.0mm²: —B—
660V SYP 3.5mm²: —C—
660V SYP 5.5mm²: —D—
660V SYP 0.75mm²: —
 - Colors of wiring
Bl: Black Blu: Blue Br: Brown R: Red Y: Yellow W: White (G): Green (for earth)
 - The ground wire is VSF 0.75mm².
 -shows the optional parts.

(3) LXE5-CAT (MFG. NO. 6800026~)

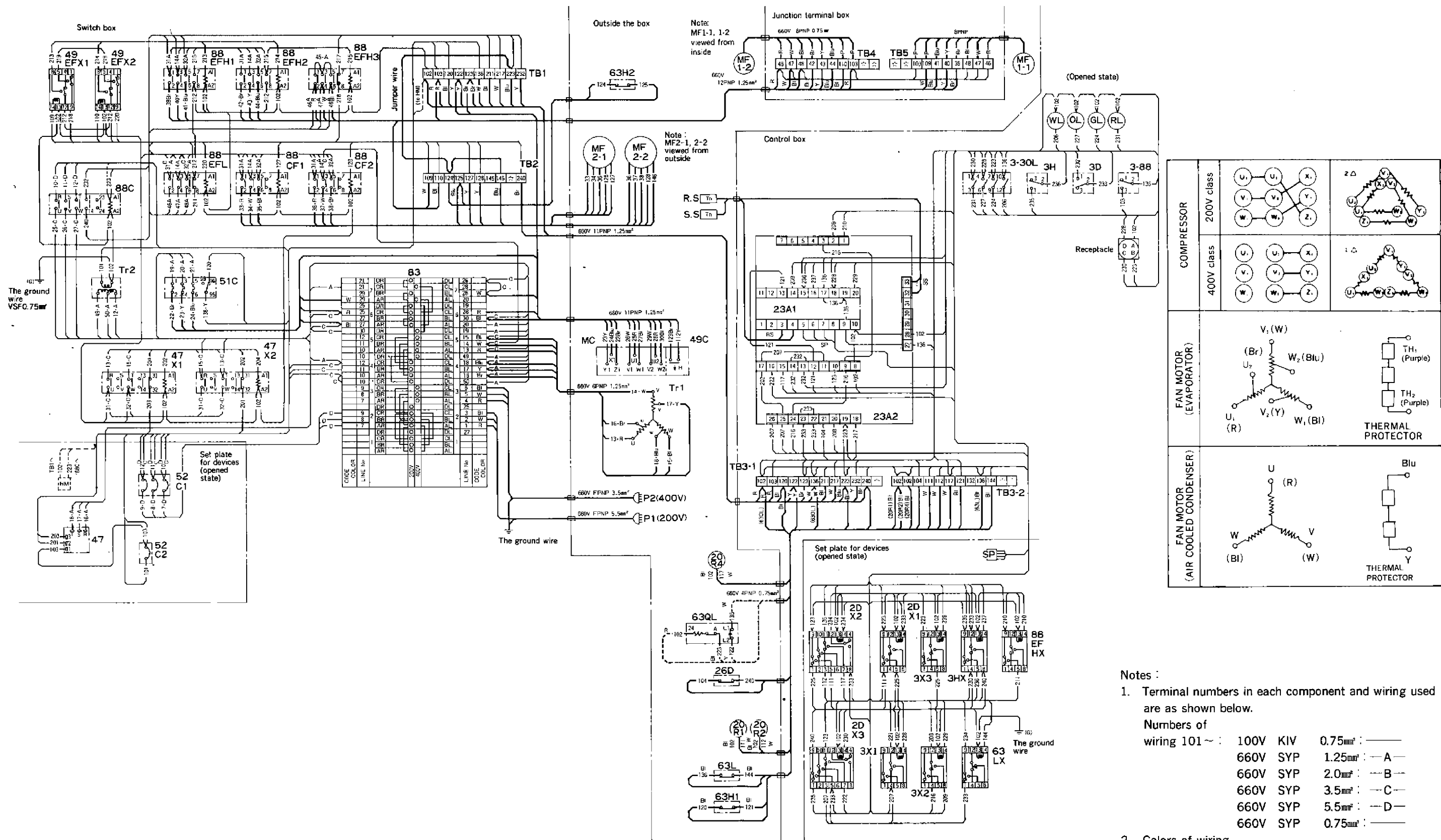

- Notes:
- Terminal numbers in each component and wiring used are as shown below.
Numbers of wiring 101 ~ : 100V KIV 0.75mm² : —
660V SYP 1.25mm² : —A—
660V SYP 2.0mm² : —B—
660V SYP 3.5mm² : —C—
660V SYP 5.5mm² : —D—
660V SYP 0.75mm² : —
 - Colors of wiring
Bl : Black Blu : Blue Br : Brown R : Red Y : Yellow W : White (G) : Green (for earth)
 - The ground wire is VSF 0.75mm².
 -shows the optional parts.

(4) LXE5-C (MFG. NO. 6700001~6800052)
 LXE5-CAT-① (MFG. NO. 6700001~6700025)
 (Note : Wiring differs with the refrigeration units)

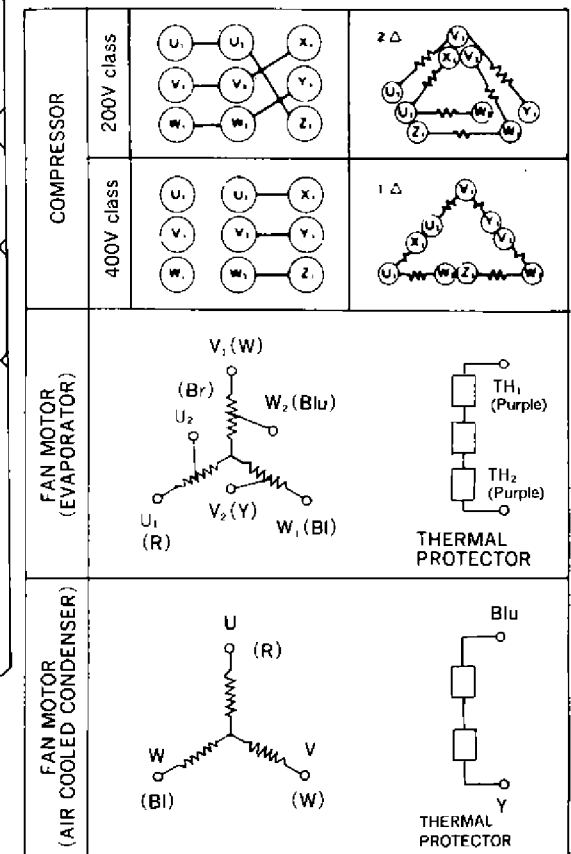
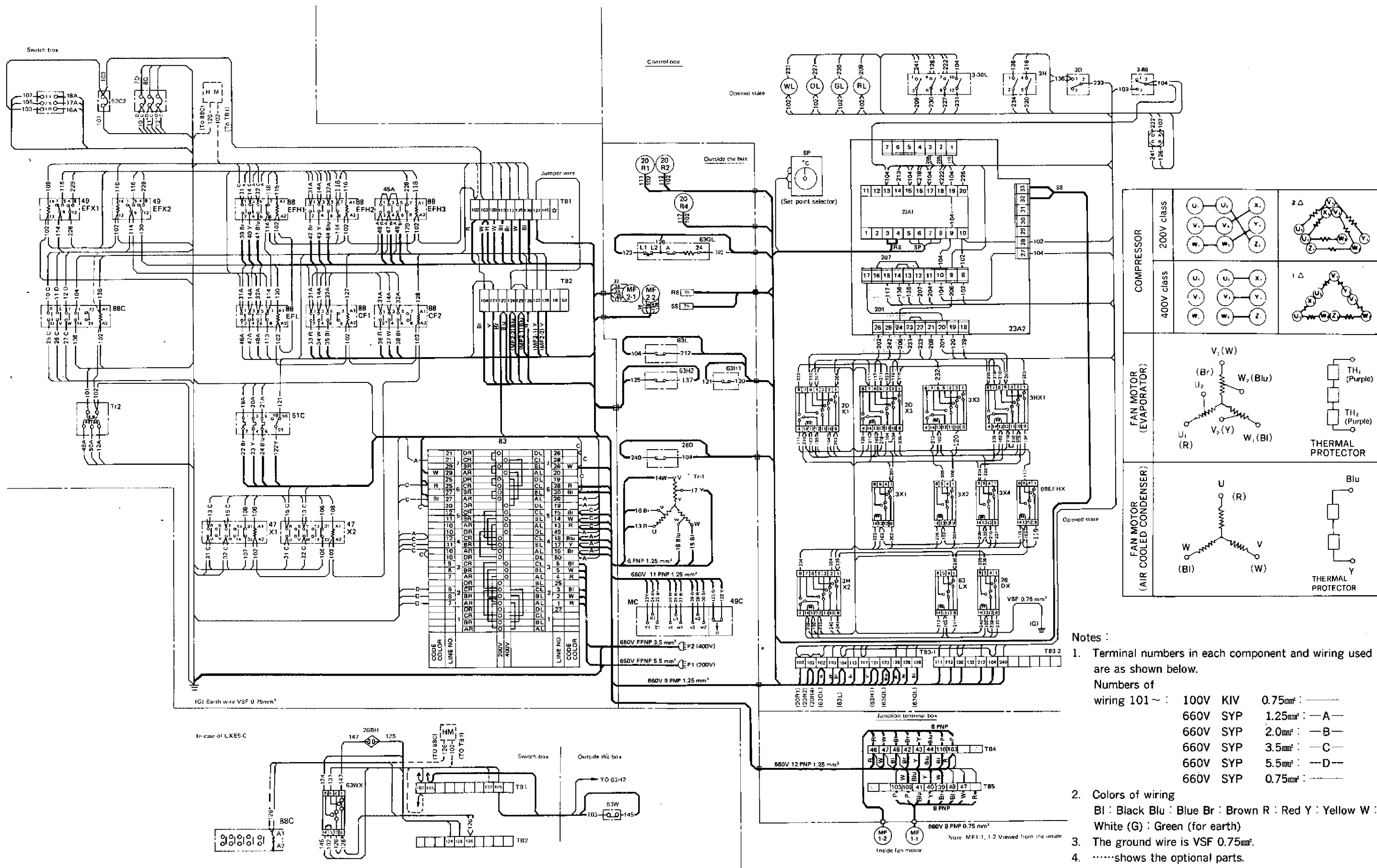

- Notes :
- Terminal numbers in each component and wiring used are as shown below.
 Numbers of wiring 101 ~ : 100V KIV 0.75mm² : —
 660V SYP 1.25mm² : —A—
 660V SYP 2.0mm² : —B—
 660V SYP 3.5mm² : —C—
 660V SYP 5.5mm² : —D—
 660V SYP 0.75mm² : —
 - Colors of wiring
 Bl : Black Blu : Blue Br : Brown R : Red Y : Yellow W : White (G) : Green (for earth)
 - The ground wire is VSF 0.75mm².
 -shows the optional parts.

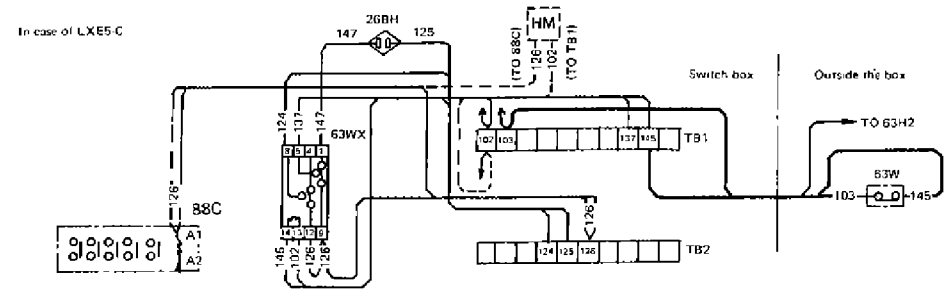

(5) LXE5-CAT-② (MFG. NO. 6700001~6700025)
 (Note : Wiring differs with the refrigeration units)

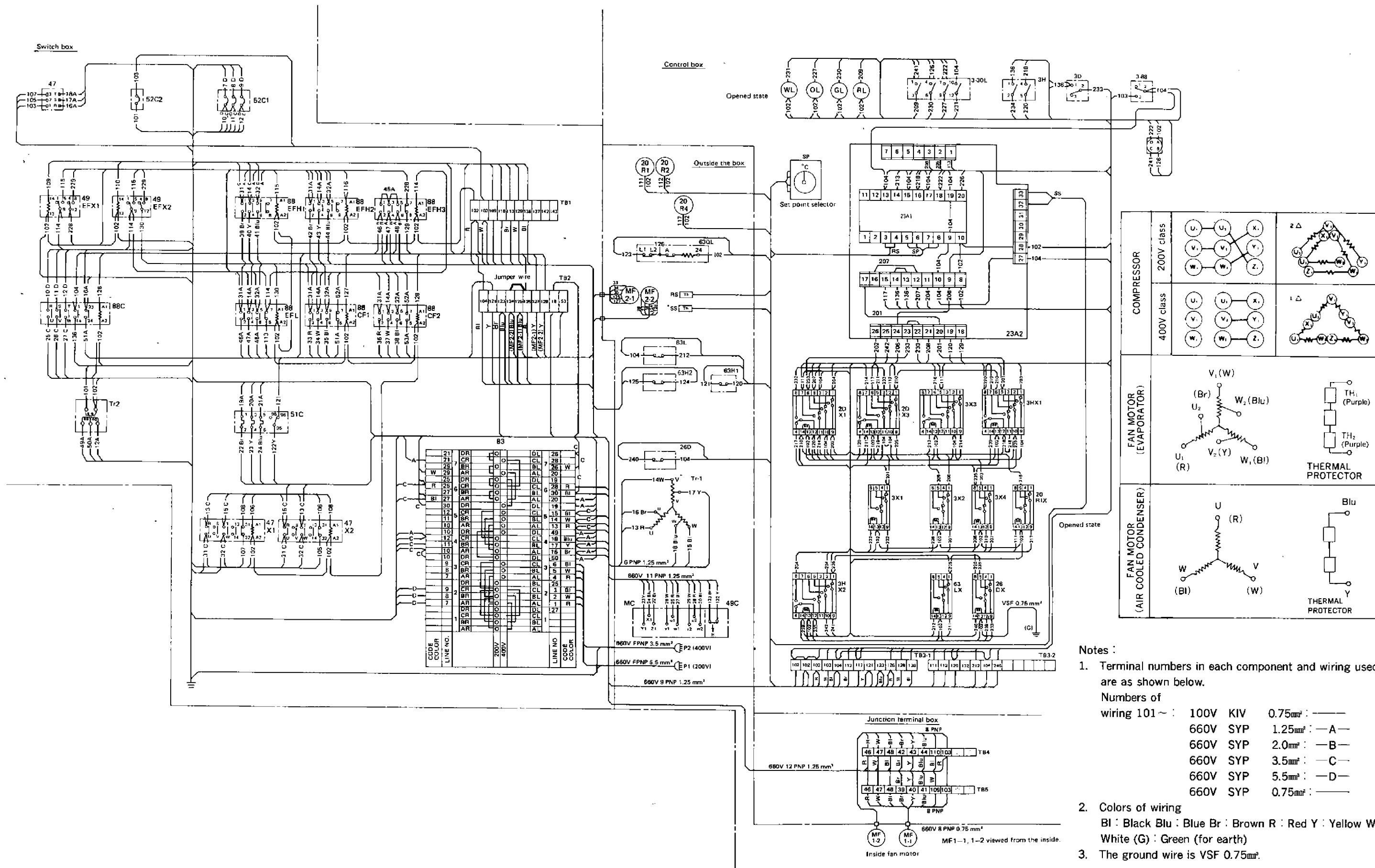

1.5 Set values of functional parts and protective devices

| Parts Name | | Mark | Function | Set Value | | |
|----------------------|---|------|---|--|---|------------------------------------|
| Pressure switch | Oil pressure protection switch (Option) ONS-C106Q | 63QL | Heater circuit OFF ON Timer | 1.0kg/cm ² 0.5kg/cm ² 110 seconds (Ambient temp. 25°C (77°F)) Over 5 seconds (Ambient temp. 70°C (158°F)) | | |
| | High pressure switch 20PS-K200 | 63H1 | OFF ON | 20kg/cm ² 16.5kg/cm ² | | |
| | High pressure control switch ACB-BA26 | 63H2 | OFF ON | 7kg/cm ² 11kg/cm ² | | |
| | Low pressure switch 20PS-K100 | 63L | OFF ON | 40cmHgV 0.2kg/cm ² | | |
| | Water pressure switch LCB-BB07 (Air/water cooled type) | 63W | OFF ON | 1kg/cm ² 0.4kg/cm ² | | |
| Thermostat and timer | Fan speed change-over thermostat | 23A2 | 2-1 (2-3) | ON (OFF) OFF (ON) | 15°C (59°F) 20°C (68°F) | |
| | ※Over-cooling protective thermostat | | Terminals | 4-5 | 29-30 short-circuit (Option) OFF ON | -1.5°C (29.3°F) +1.5°C (34.7°F) |
| | | | | 6-7 | 29-30 open (Factory set) OFF ON | -3°C (26.6°F) 0°C (32°F) |
| | | | | | Low temp. side ON OFF | -10°C (14°F) -7°C (19.4°F) |
| | High temp. side ON OFF | | 9°C (48.2°F) 10°C (50°F) | | | |
| | | | Fan operation delay timer | 2F1 | ON | 60 seconds |
| | Fan Hi/Lo speed change-over timer | | 2F2 | ON | 10 seconds | |
| | Defrost timer | | Short Long Compressor stop Back-up | 2D1 | ON | 4 hours |
| | | | | 2D2 | ON | 12 hours |
| | | | | 2D3 | ON | 20 seconds |
| | | | | 2D4 | OFF | 90 minutes |
| Thermostat | Defrost thermistor ST-5B 30/20 | 26D | OFF ON | 35°C (95°F) 20°C (68°F) | | |
| | Switch box thermostat CS-7 (Air/water cooled type) | 26BH | OFF ON | 35°C (95°F) 50°C (122°F) | | |
| Breaker OC | Over-current relay GT-20-NP2S4 | 51C | OFF | 5.8A | | |
| | Circuit breaker (Main circuit) MK53 | 52C1 | OFF | 32A | | |
| | Circuit breaker (Control circuit) CP31/7-Z | 52C2 | OFF | 7A | | |
| Motor | Condenser fan motor protective thermostat | 49CF | OFF | 135°C (275°F) | | |
| | Evaporator fan motor protective thermostat | 49EF | OFF | 120°C (248°F) | | |
| | Compressor protective thermostat | 49C | OFF | 105°C (221°F) | | |

Note : The devices marked with ※ may sometimes not be used depending on models.

1.6 Operation pressure and running current

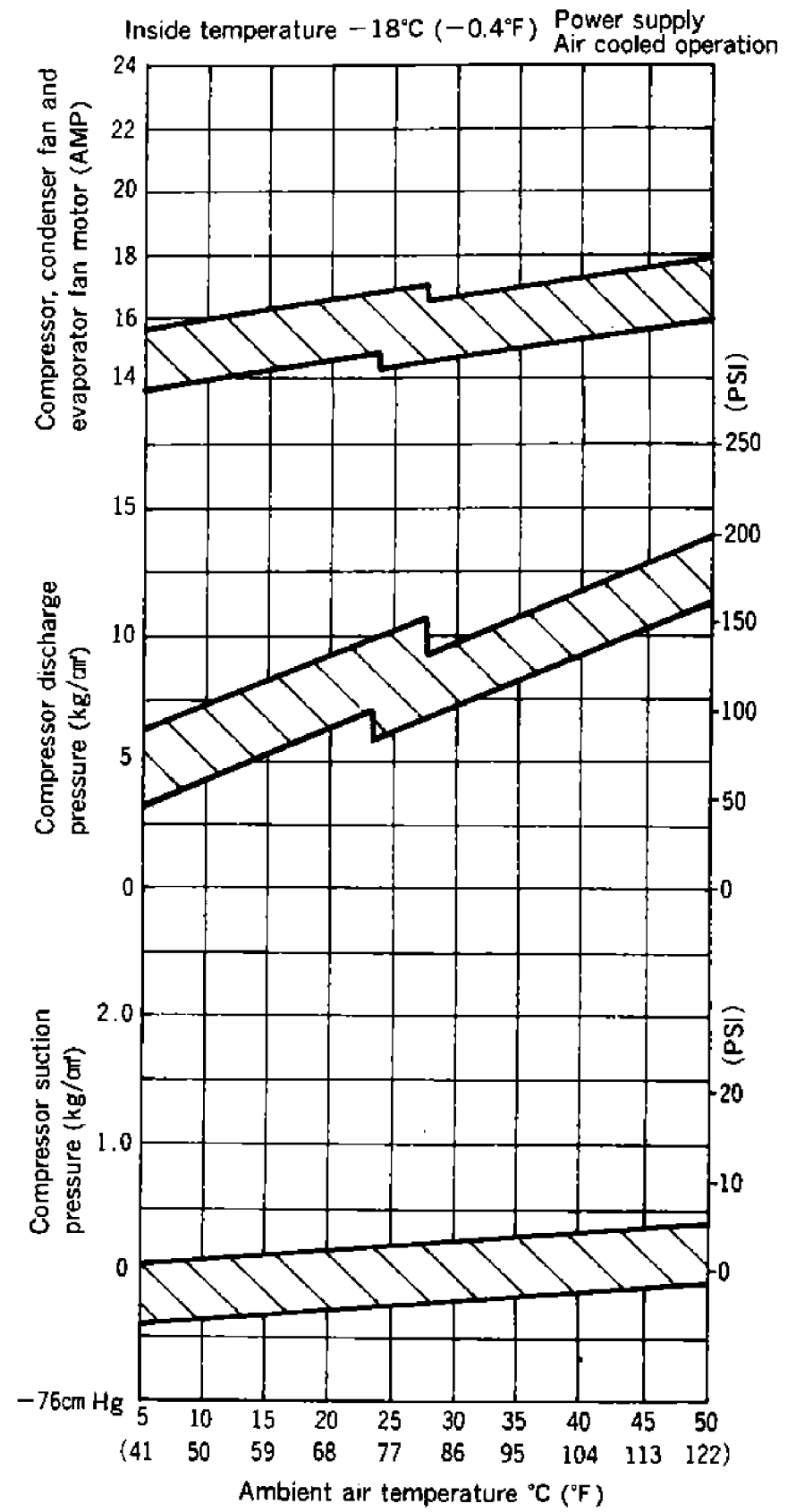
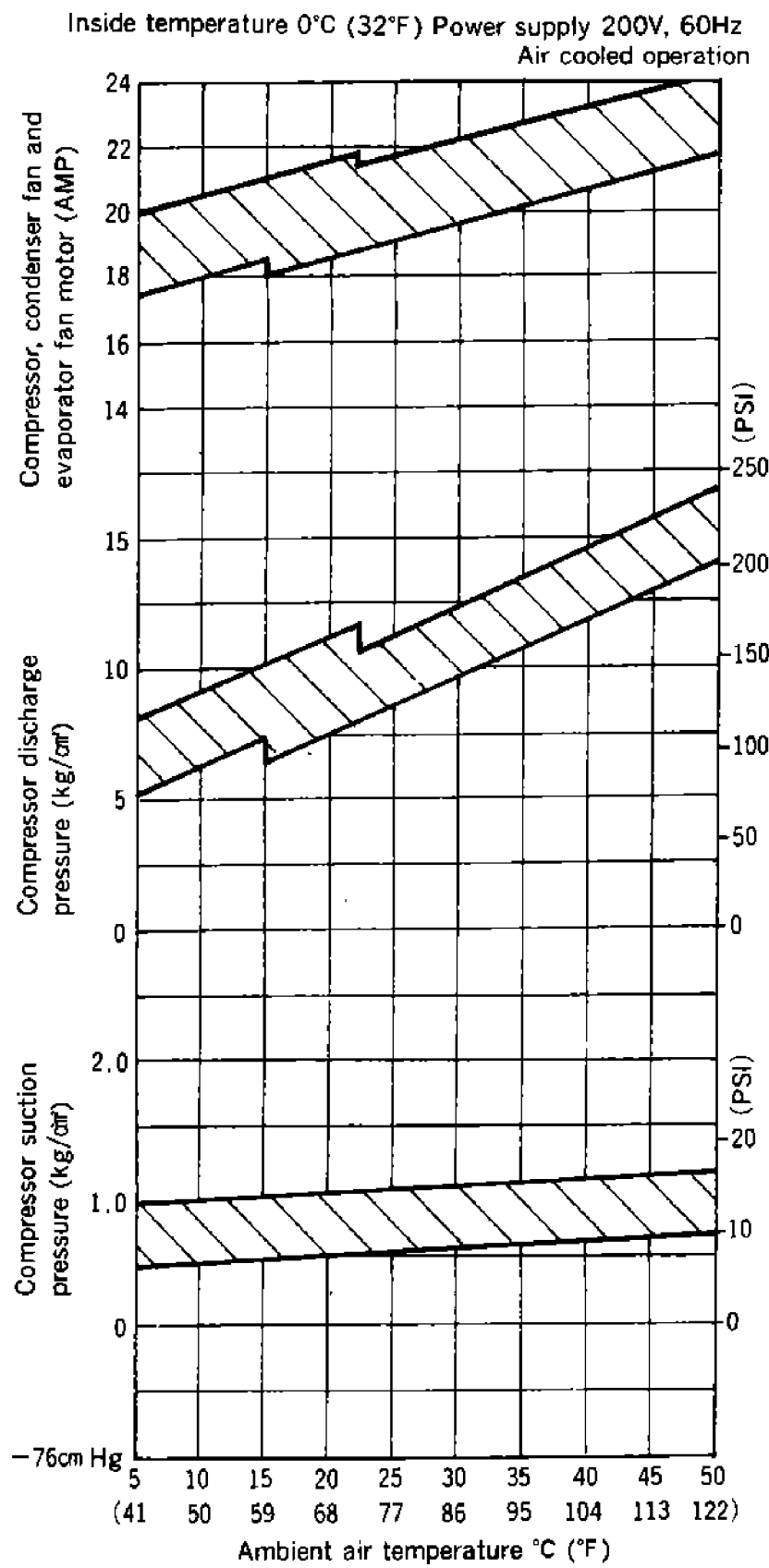

<For reference>

| | Item | Unit | Value |
|---|--|------|-------------------------|
| 1 | Condenser fan motor Running current (for 2 pcs.) | A | 0.7 (AC400V) |
| 2 | Evaporator fan motor Running current (for 2 pcs.) | A | High speed 2.6 (AC400V) |
| | | | Low speed 0.7 (AC400V) |

2. Operation modes and circuits

2.1 How to read wiring diagram

(1) In the wiring diagram, marks and numbers have the meanings given below.

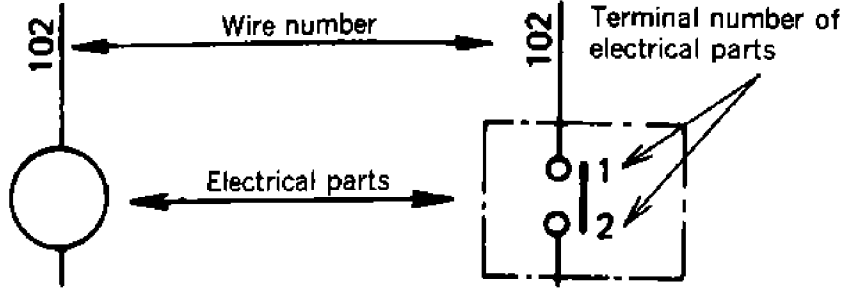

(2) Operation of contacts

- a. The wiring diagram indicates the stationary state in which the circuits are not activated.
- b. when a coil is energized (supplied with power), the associated contact changes its position.

| | |
|---------------------------------|--|
| a-contact (normal open contact) | <p>Contact is OFF when coil is not energized</p> |
| | <p>Contact is ON when coil is energized</p> |
| | <p>Contact is ON when coil is not energized</p> |
| | <p>Contact is OFF when coil is energized</p> |

c. Kinds of contacts

| | | |
|--|---|--|
| | A-contact | Operated by electromagnetic force, temperature, or pressure. ("X" denotes the manual reset.) |
| | b-contact | |
| | Time-limit a-contact | Operates when the timer counting has completed. |
| | Manual contact | Contact of a snap switch. This turns on as long as the switch is kept pressed and turns off immediately when released. |
| | Manual contact | Contact of a snap switch. This turns on and holds the on state once the switch is turned on. |
| | Voltage selector contact (except 3-88, 3-30L) | This turns on when the selector is set to 200V class |
| | | This turns on when the selector is set to 400V class |

d. How to read the wiring diagram of the voltage selector switch.

In the chart, "●" denotes that the contact is on.
The following example shows the states between terminals AL2 and AR2, and between AL3 and AR2.

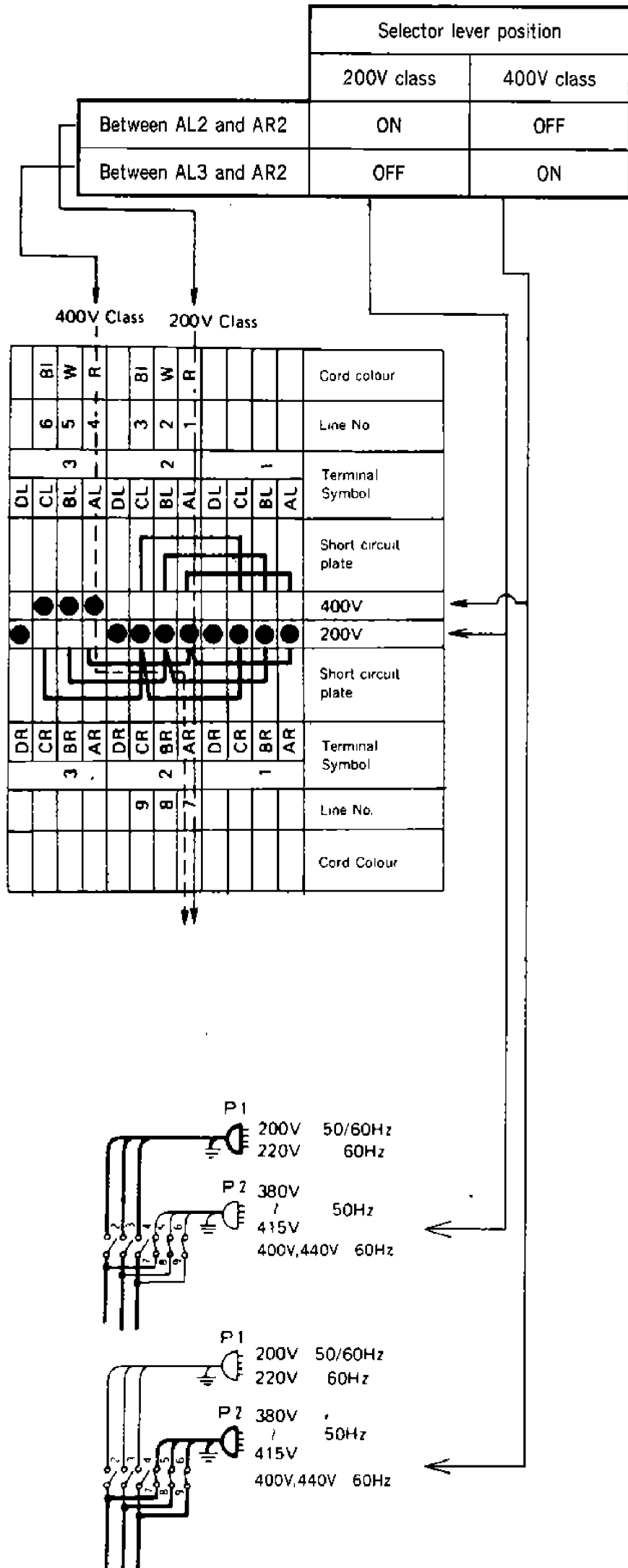

2.2 High pressure control

When ambient temperature drops during air cooled operation, condensing pressure (high pressure) drops accordingly.

In addition, low pressure drops in accordance with condensing pressure drop and cooling capacity reduces. In order to prevent high pressure from dropping, the high pressure control pressure switch (63H2) is installed to turn off the magnetic switch (88CF1) for condenser fan when high pressure drops lower than 7 kg/cm². So one of the condenser fan (MF2-1) stops automatically, which prevents high pressure from dropping.

2.3 Air cooled and water cooled operation (Air/water cooled type)

The unit is possible to operate on either operations of air cooled or water cooled.

During the transit on the land, in the yard or on the deck, the air cooled operation is normal, and the operation in ship holds is normally water cooled. The operation can be changed from air cooled to water cooled and vice versa automatically by the water pressure switch; i.e. when water pressure at the inlet of the water cooled condenser rises higher than the presetting value, the contact points of the water pressure switch are cut out, so the condenser fan motors stop, and the water cooled operation starts. On the contrary, when water supply is suspended during the water cooled operation, the contact points of the water pressure switch come in contact and the condenser fan motors rotate. Thus, the air cooled operation starts.

Note :

Note that the condenser fan on the left may sometimes operate to cool the control box during water cooled operation.

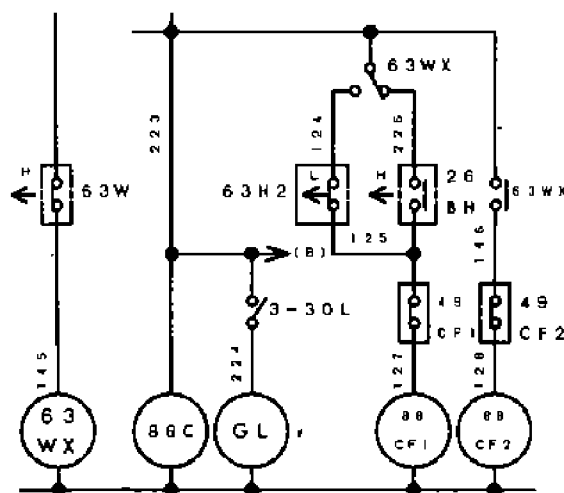

**2.4 Voltage selector system
(Change-over for 200V/400V class)**

(1) The dual rating system is adopted to the compressor motor and the transformer method to the fan motor of the units. Turn the lever of the voltage selector switch (multi-contact cam switch) manually in accordance with the power supply available to change the wiring of the transformers of each motor and the control circuit suited for respective power supply. The internal wiring of the dual rating system in the compressor is as shown on the right.

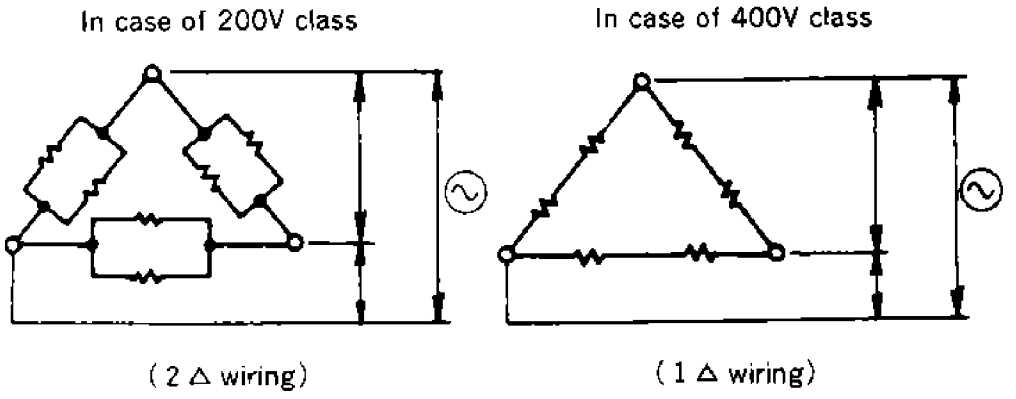

(2) Circuit formation
○ In case of 200V class (Set the selector lever to "200V Class".)

The contacts (except 3-88 and 3-30L) shown by  have continuity on the sequence diagram.

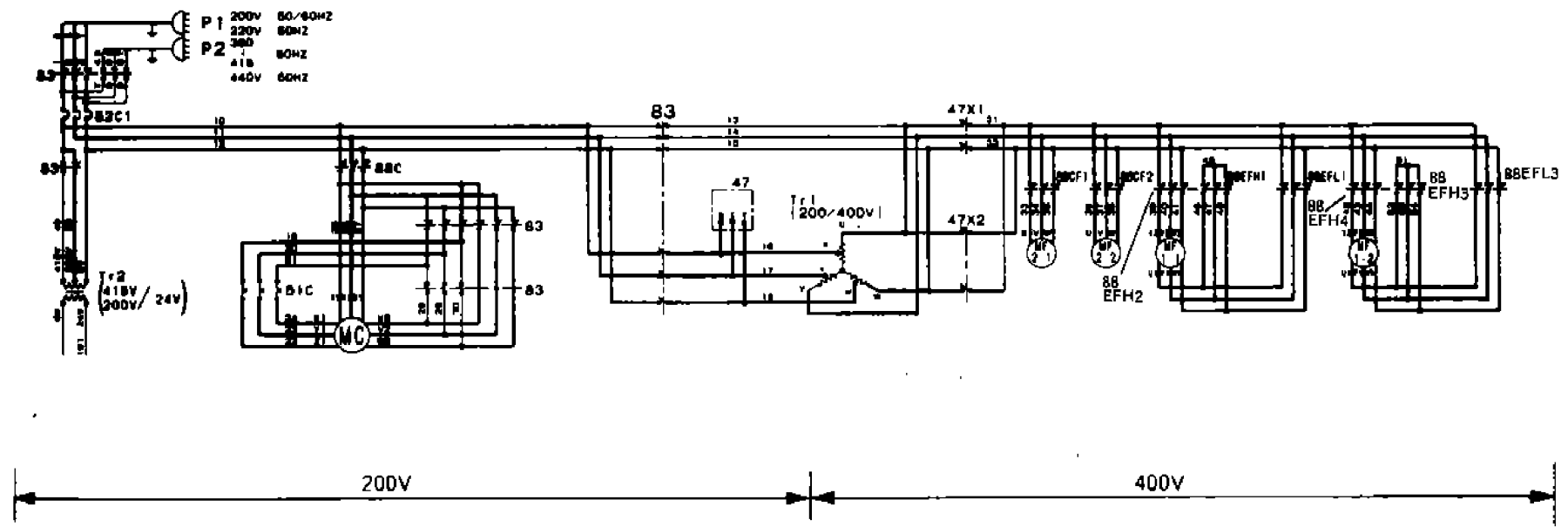

○ In case of 400V Class (set the selector lever to "400V Class".)

The contacts shown by  have continuity on the sequence diagram and from the 400V class circuit.

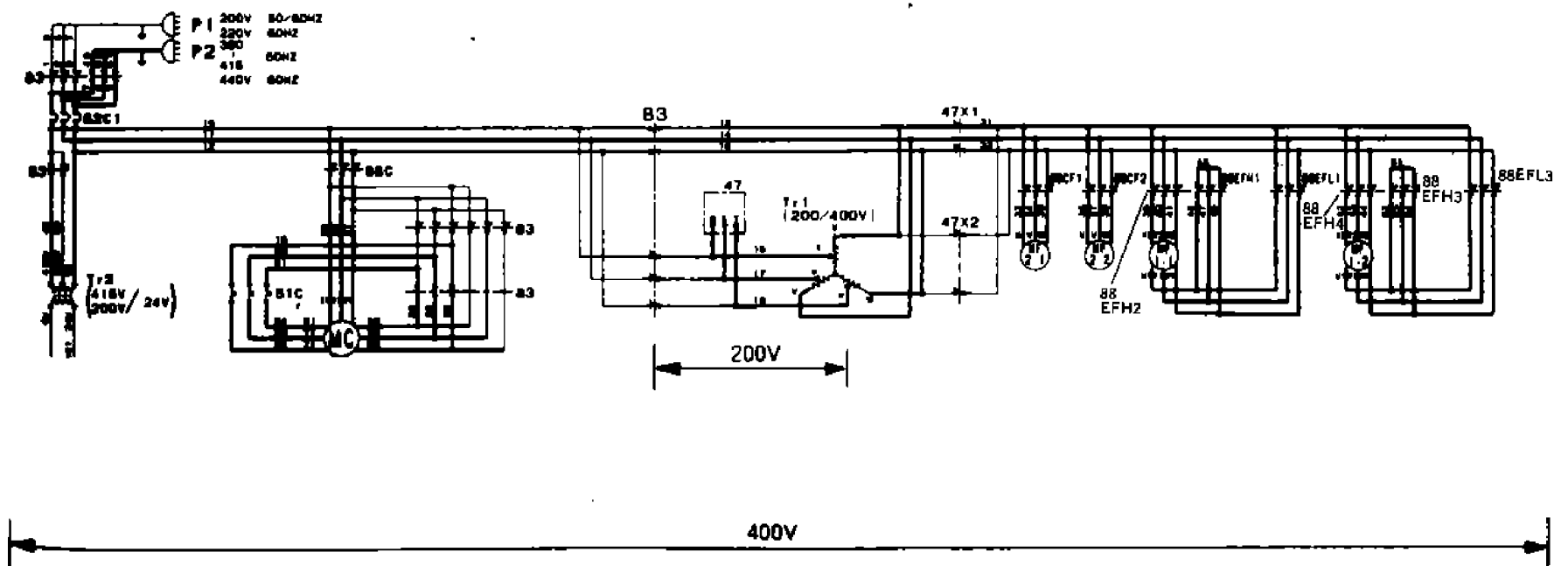

(3) Phase selection

The reversible method is adopted to the compressor and the proper phase selection method to the fan motor of the units.

○ Compressor

The hydraulic pump adopted is a reversible trochoid pump, so the predesigned oil pressure can be obtained regardless of turning direction of the built-in motor.

○ Fan motor

The phase sequence controller adopted exchanges R phase with T phase automatically in case of wrong phase.

47: phase sequence controller

47X1·2: Magnetic switches for phase selection.

● Proper phase

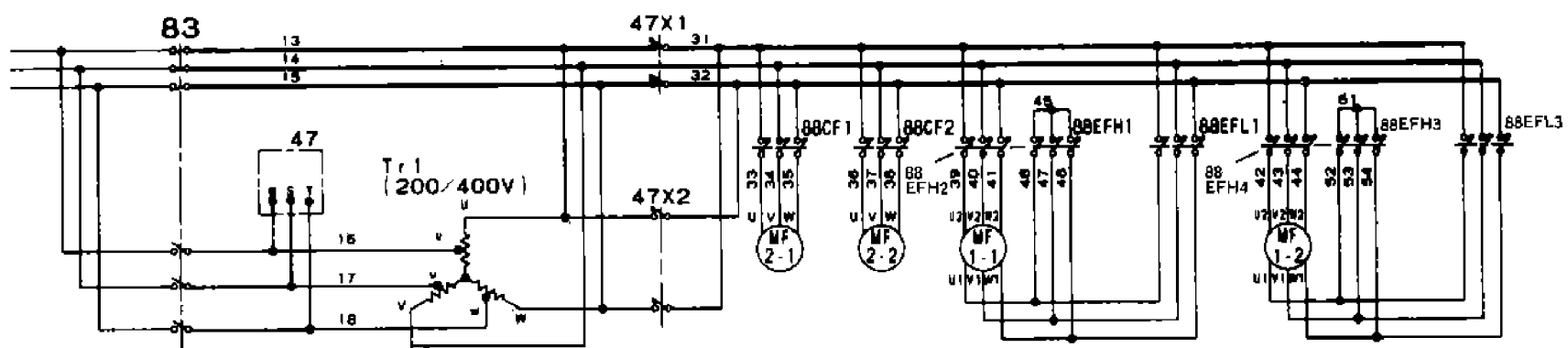

● Wrong phase

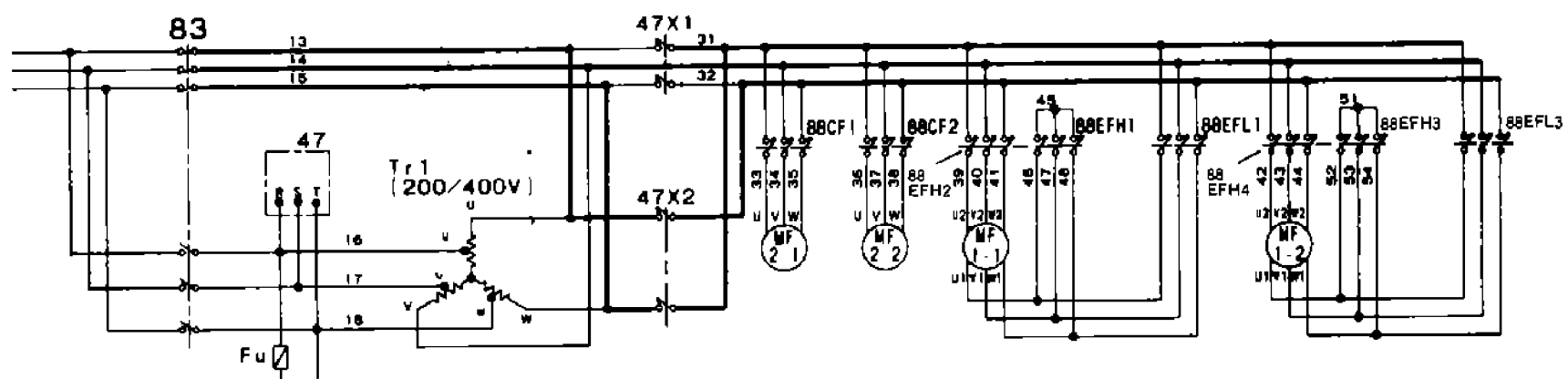

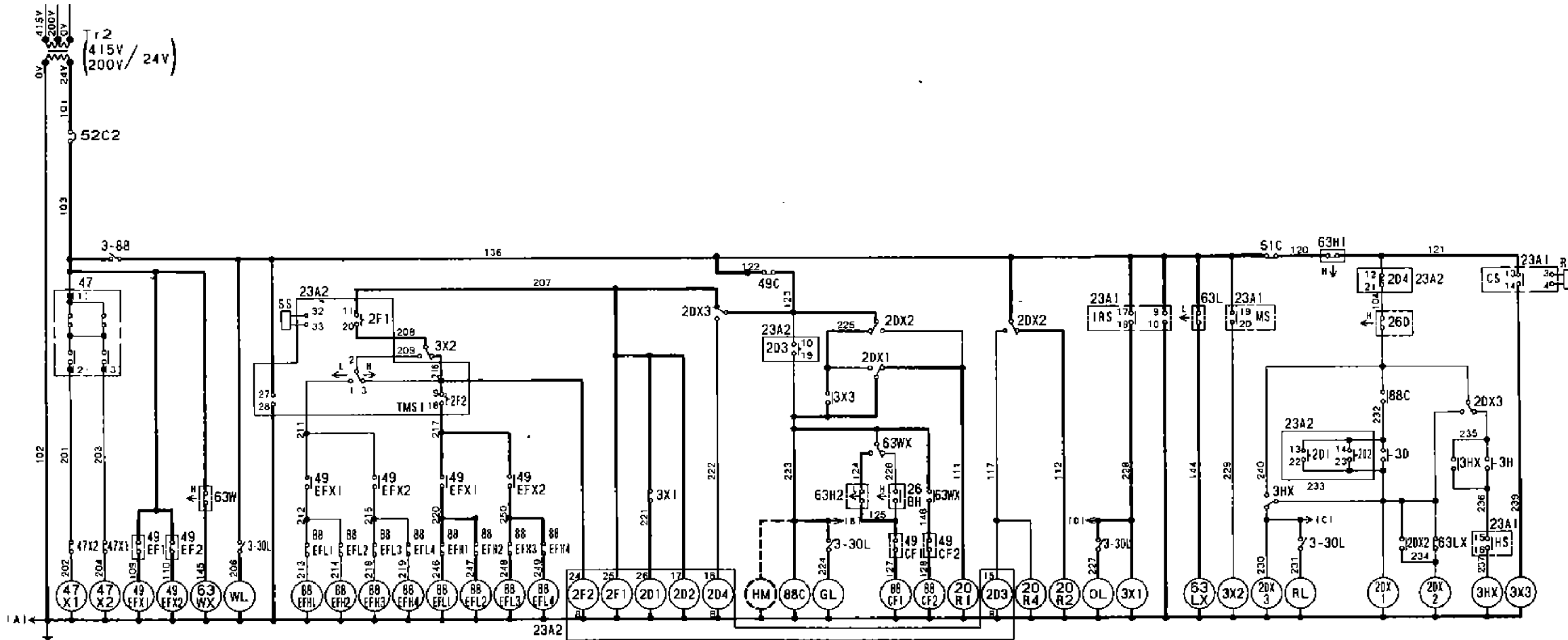

43

- (1) Change-over for frozen-chilled is performed automatically by means of setting of the electronic controller.
 Chilled operation: above -4.5°C ($+23.9^{\circ}\text{F}$)
 Frozen operation: below -6.5°C ($+20.3^{\circ}\text{F}$)
- (2) When the unit ON-OFF switch (3-88) is turned on,
 - (a) The pilot lamp for power supply lights up.
 - (b) The measuring liquid solenoid valve (upstream side) (20R2) is open.
 - (c) The fan will operate after a lapse of 70 seconds by the delay timers (2F1, 2F2).

- (3) The compressor is operated on and off by sensing the return temperature of the evaporator.
 Compressor OFF: Preset temperature (ⓑ point)
 Compressor ON: Preset temperature $+1.1^{\circ}\text{C}$ ($+2^{\circ}\text{F}$) (Ⓒ point)
 When the compressor operates,
 The pilot lamp for compressor operation (Green) lights up.
 The condenser fans operate.
 The main liquid solenoid valve (downstream side) (20R1) opens.
- (4) When return air temperature in the storage drops to the preset temperature, the in range lamp (Orange) lights up.

| | Upper limit | Lower limit |
|------------------|---|---|
| ON (Ⓐ point) | $+2.5^{\circ}\text{C}$ ($+4.5^{\circ}\text{F}$) | -2.5°C (-4.5°F) |
| OFF (Ⓓ point) | $+3.6^{\circ}\text{C}$ ($+6.5^{\circ}\text{F}$) | -3.6°C (-6.5°F) |

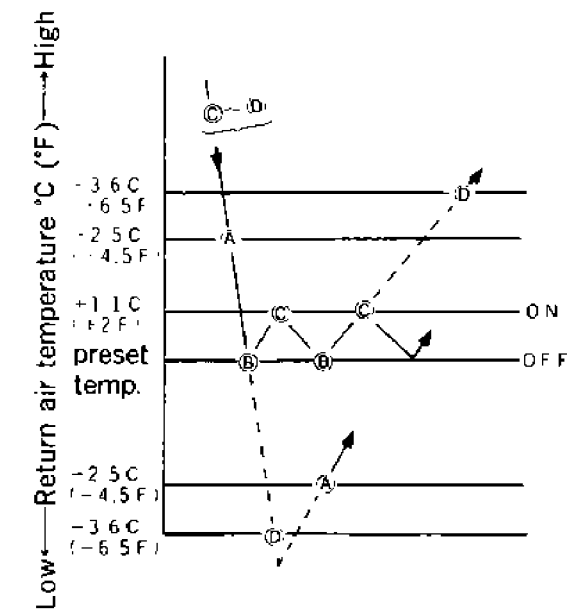

<Sequence operation>

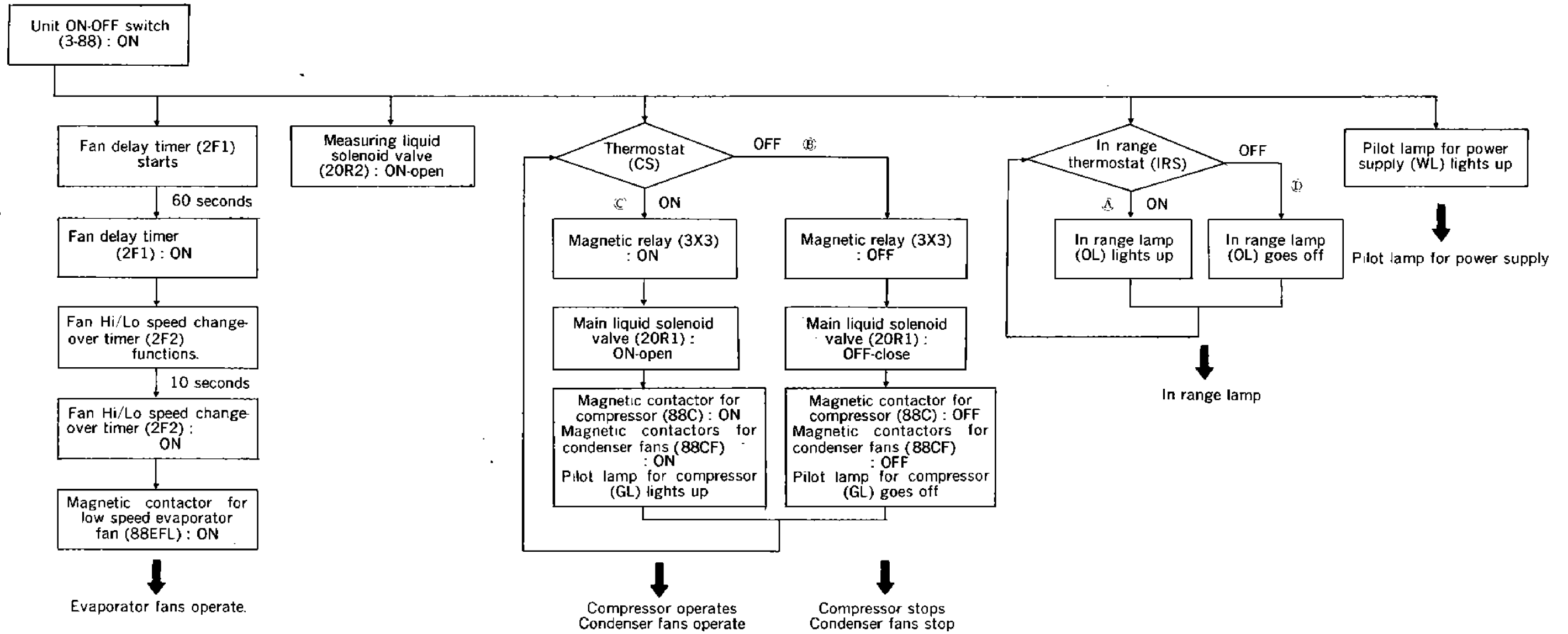

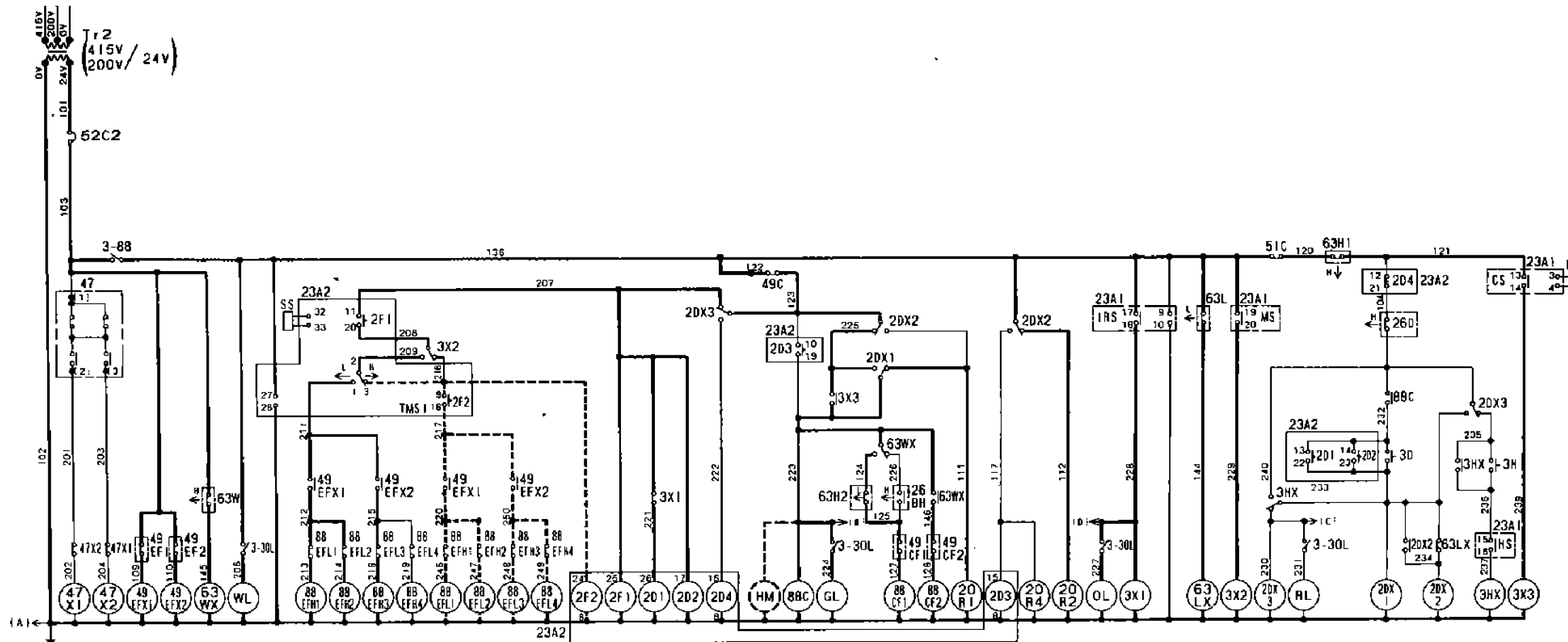

45

The difference between chilled operation and frozen operation is operation of the evaporator fan circuit only.

Frozen operation

The evaporator fans operate always in low speed.

Chilled operation

(1) Speed of the evaporator fans are changed from Hi to Lo and vice versa by the supply air thermostat (23A2-TMS1) of the electronic controller.

Supply air temperature : above 20°C (68°F)Low fan speed operation

Supply air temperature : below 15°C (59°F)High fan speed operation

If supply air temperature reaches to the temperatures shown above during pull-down operation, the evaporator fan speed will be changed automatically from Lo to Hi.

(2) When the fan speed is changed from Hi to Lo, 10 seconds Will be delayed in order to prevent reverse torque.

Sequence operation

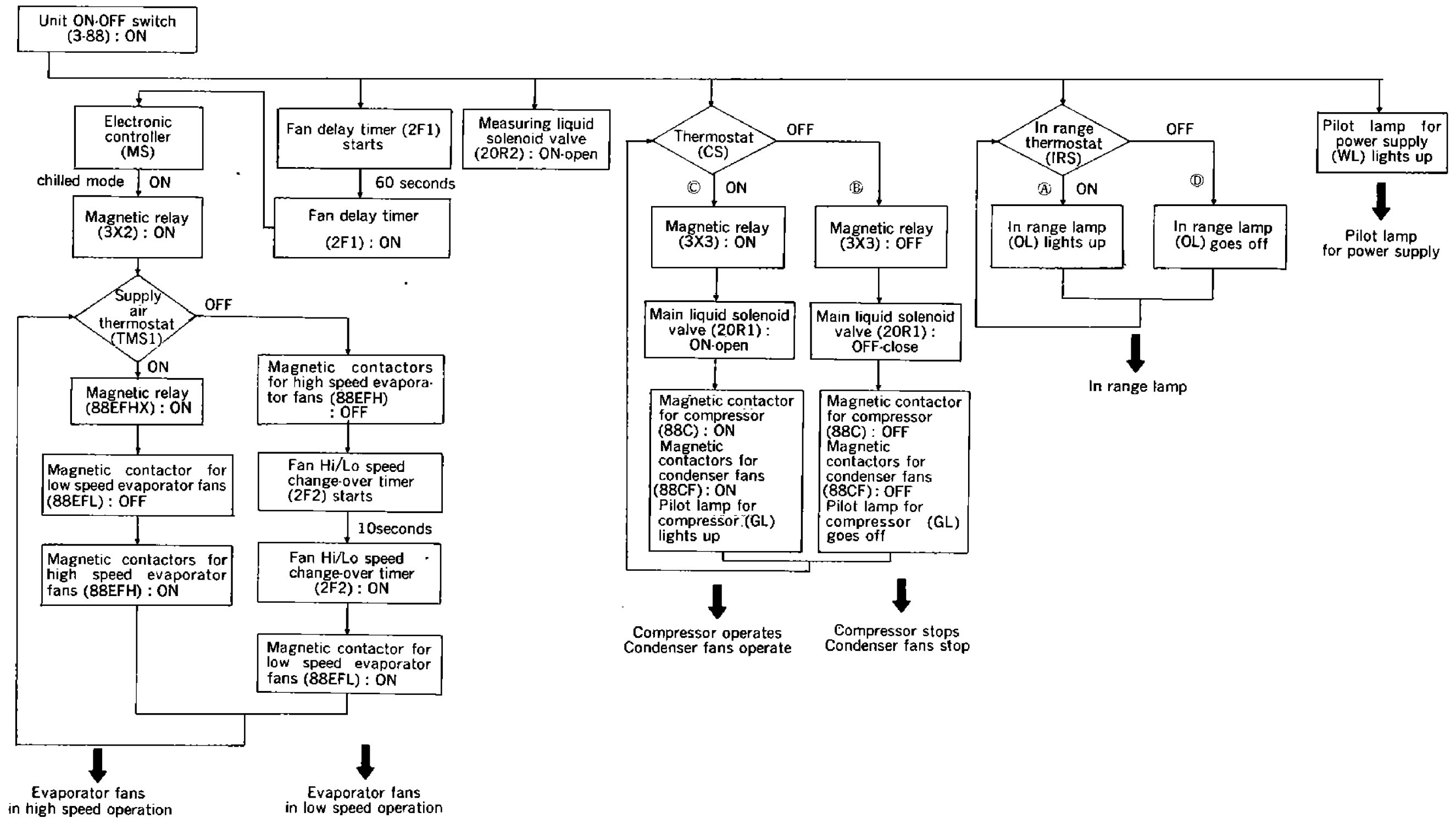

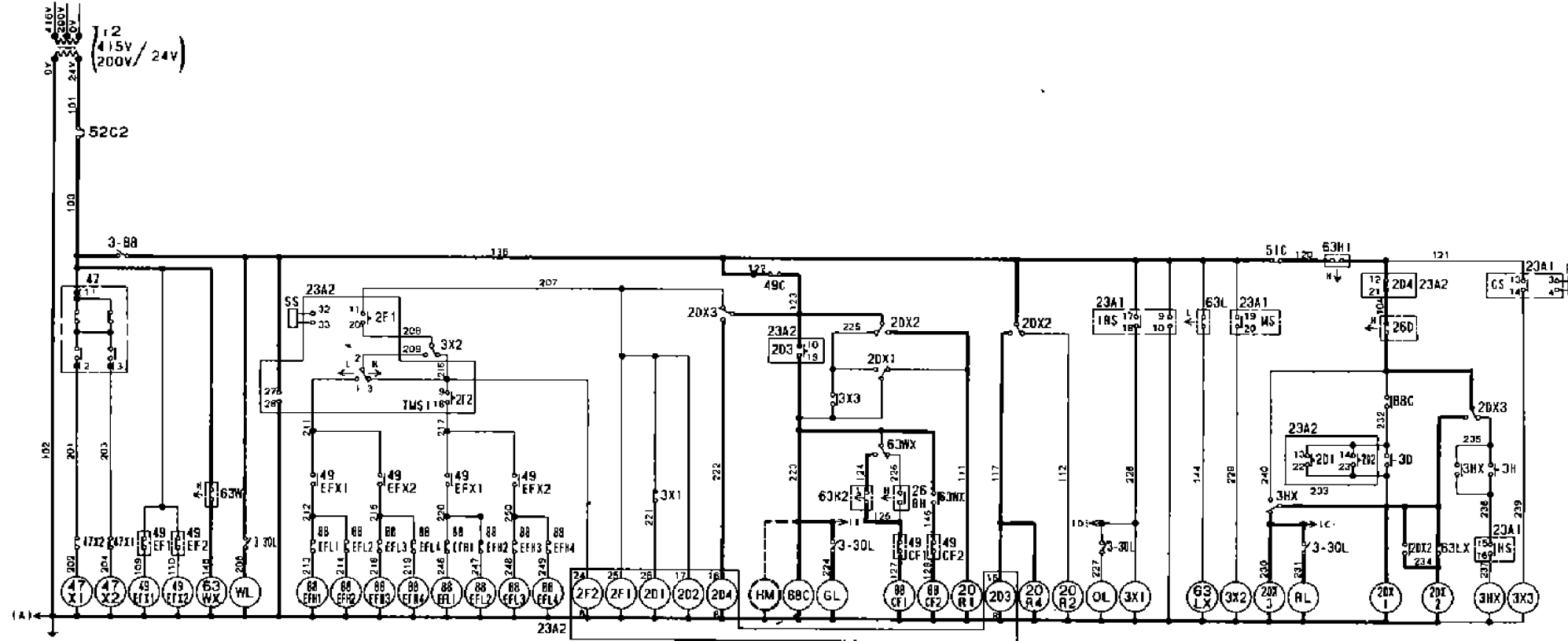

The hot-gas defrost system is adopted in the units; i.e. the high temperature and high pressure refrigerant (hot gas) from the compressor is sent to the evaporator and drain pan for defrosting. Since the evaporator is heated directly by the hot refrigerant in the evaporator, defrosting can be performed effectively.

- (1) Defrosting starts
 - The dual timer method and manual switch method are adopted to start defrosting.
 - (a) Dual timer method
 - Short-cycle defrosting

During the time when return air temperature drops to the in range temperature from pull down operation, defrosting starts every 4 hours by the short timer (2D1) of the electronic controller (23A2).
 - Long cycle defrosting

When return air temperature becomes within in range temperature (in range lamp lights up), defrosting starts every 12 hours by the long timer (2D2) of the electronic controller (23A2).

- (b) Manual switch method
 - When the manual defrost switch (3D) is set to "MANUAL", defrosting starts.
 - (2) Defrost operation

The devices and components operate as shown below during defrost operation
 - (3) When over current relay (51C) or high pressure switch (63H1) operates during defrost operation, defrost operation stops and change to cooling operation.

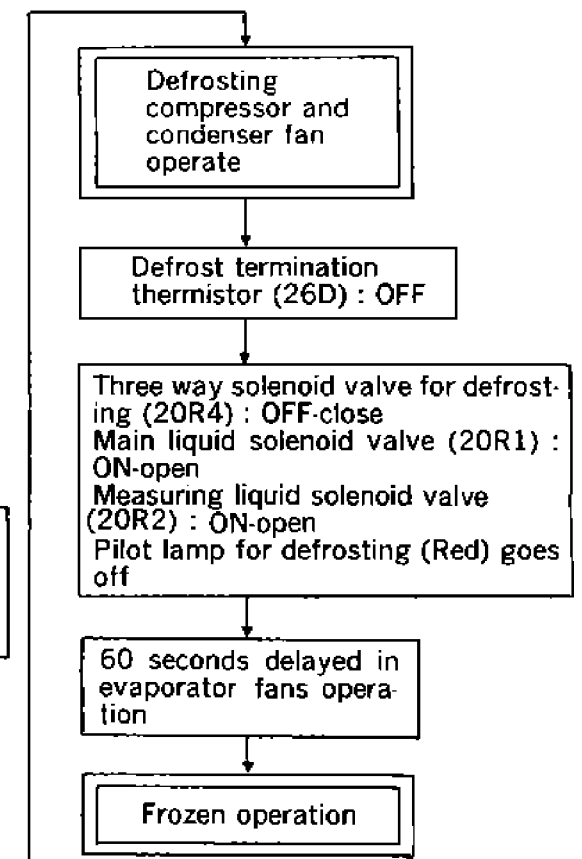
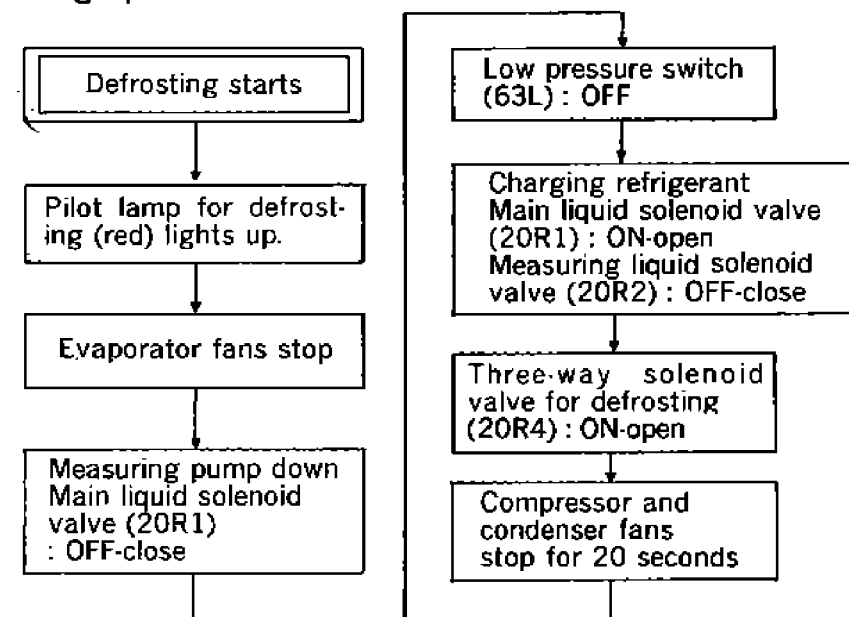

<Sequence operation>

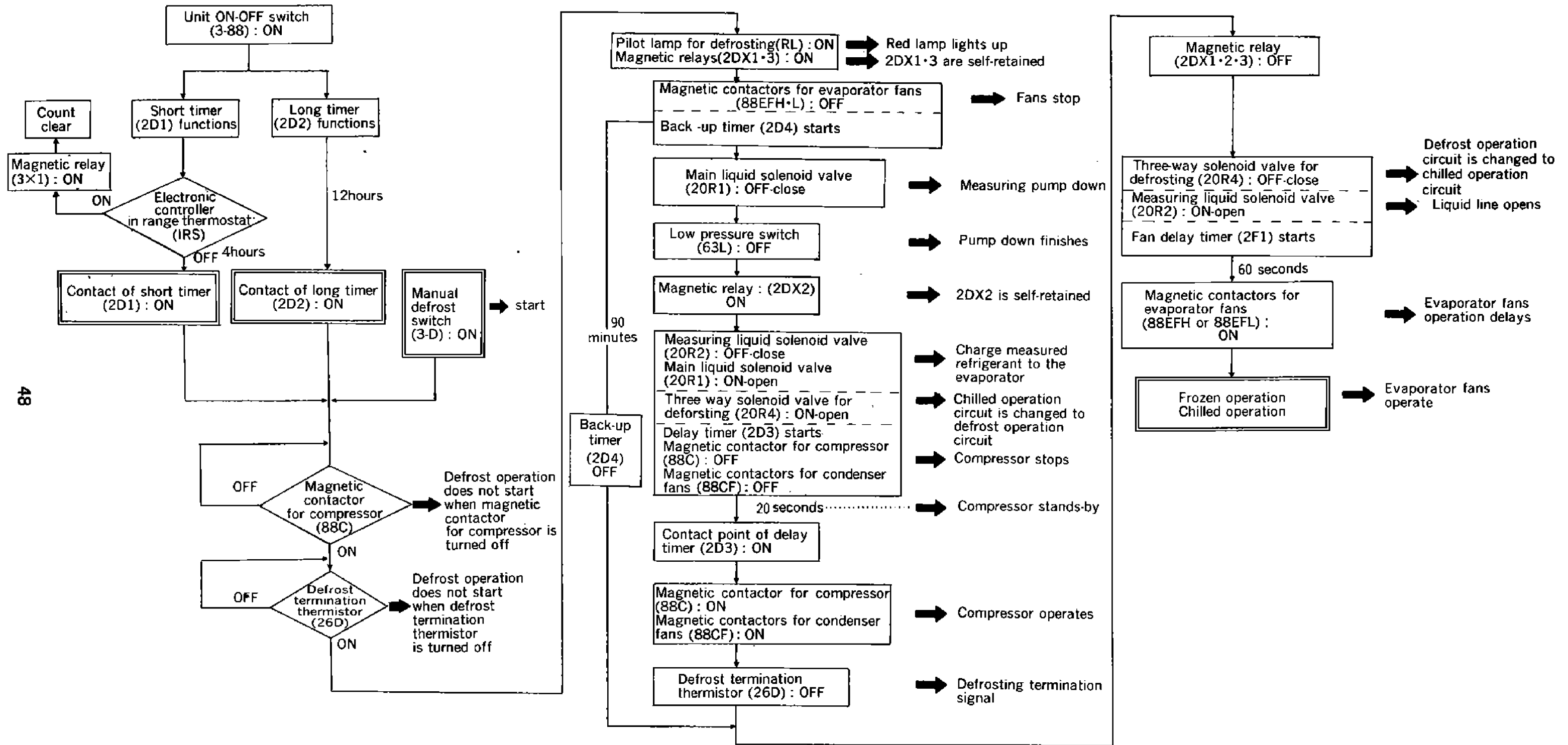

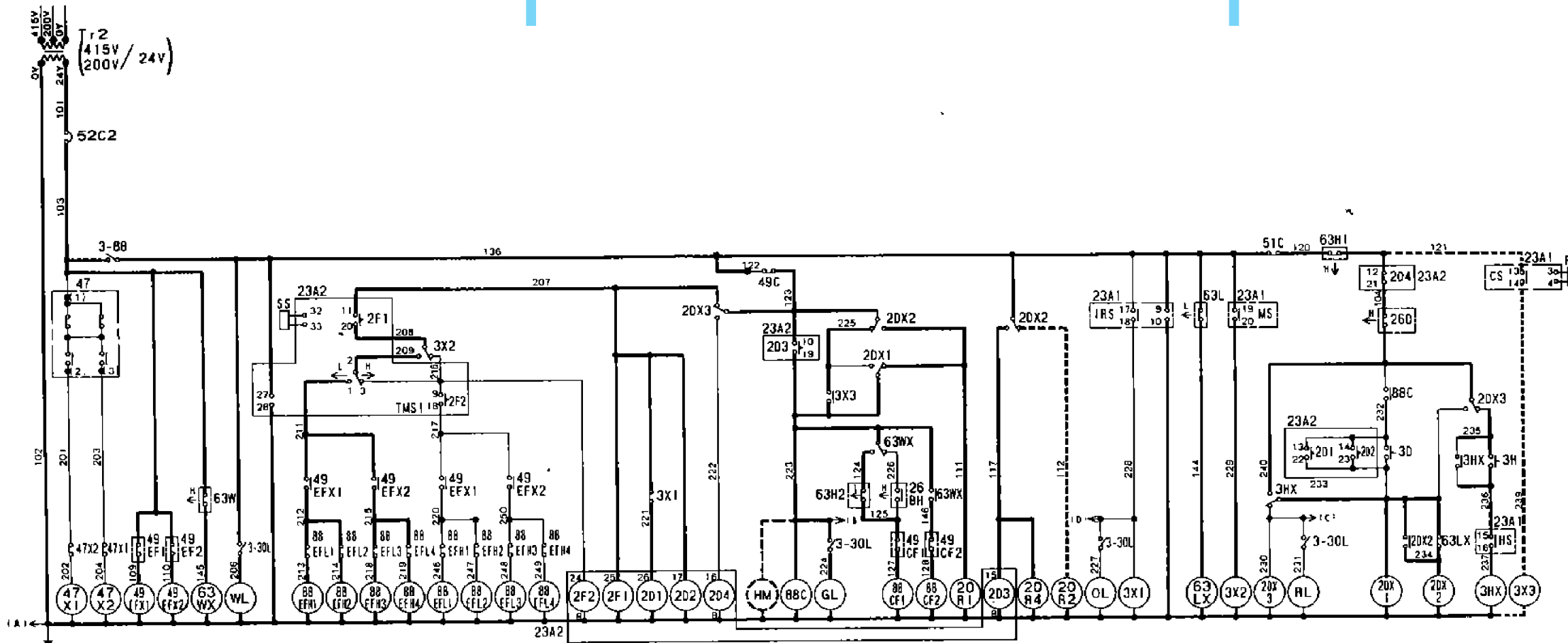

49

The hot gas heat-up system is adopted in the units; i. e. the high temperature and high pressure refrigerant (hot gas) from the compressor is sent to the evaporator to heat inside temperature.

- (1) Starting of heat-up
Heat-up is performed only when the thermostat is set to "chilled mode" (above -4.5°C [$+23.9^{\circ}\text{F}$]). Heat-up operation starts when the heat-up switch (3H) is set to "ON".
- (2) Heat-up operation
The devices and components operate as described on the right during heat-up operation
- (3) When over current relay (51C) or high pressure switch (63H1) operates during heat-up operation, compressor stops and only evaporator fan motors continue to heat up.

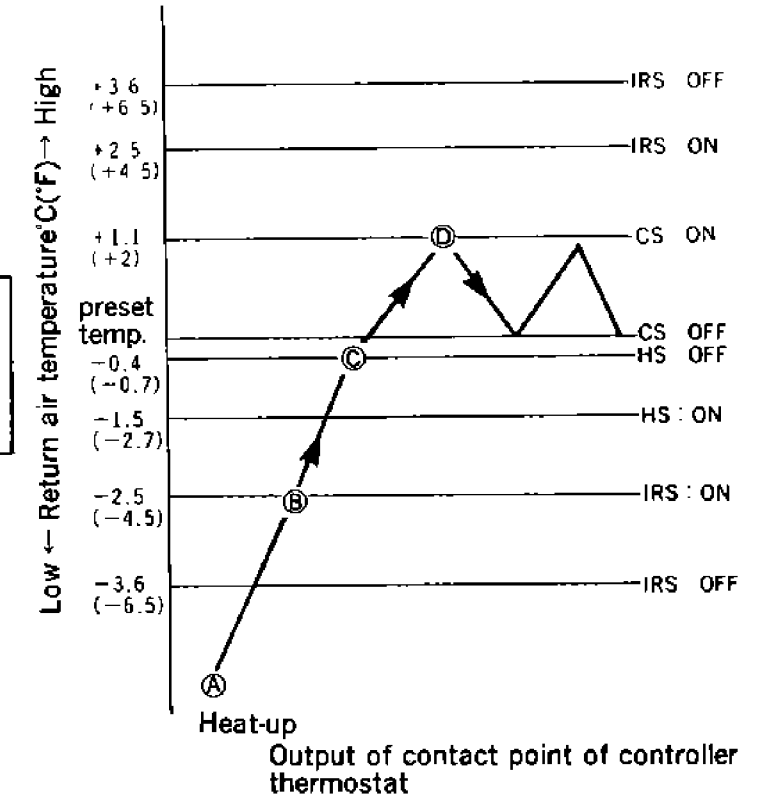
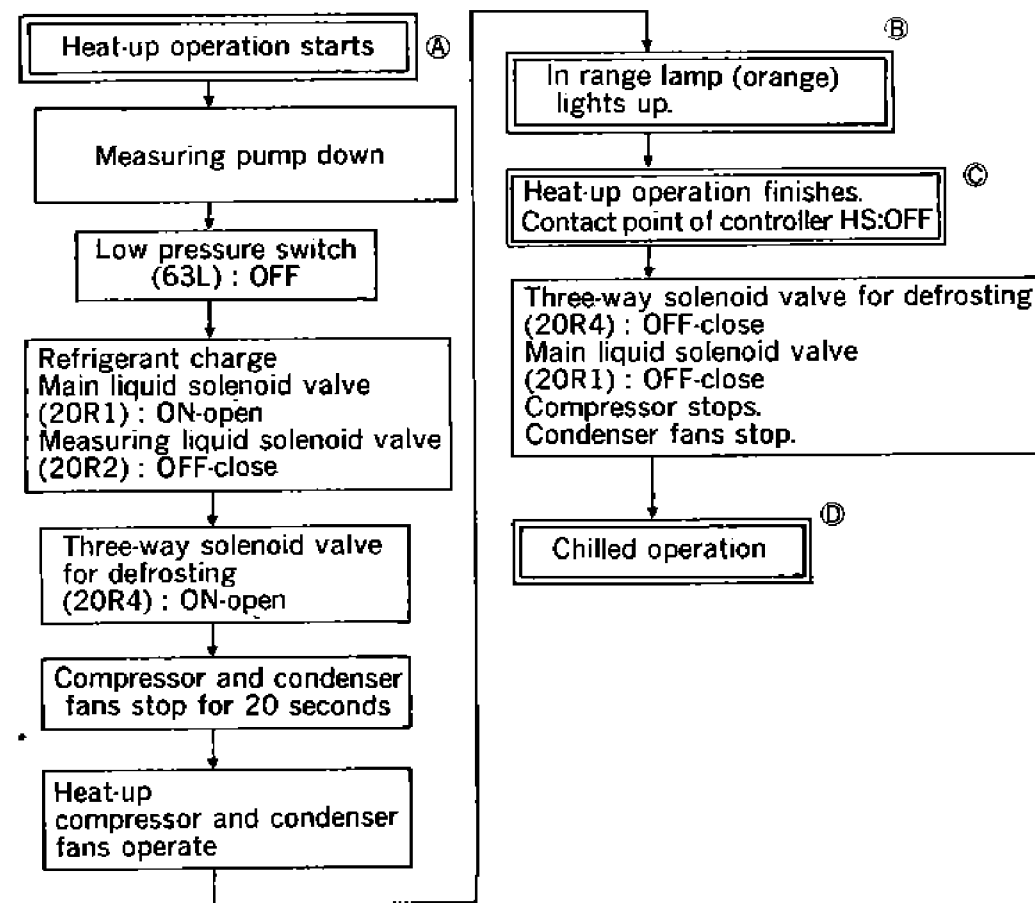

<Sequence operation>

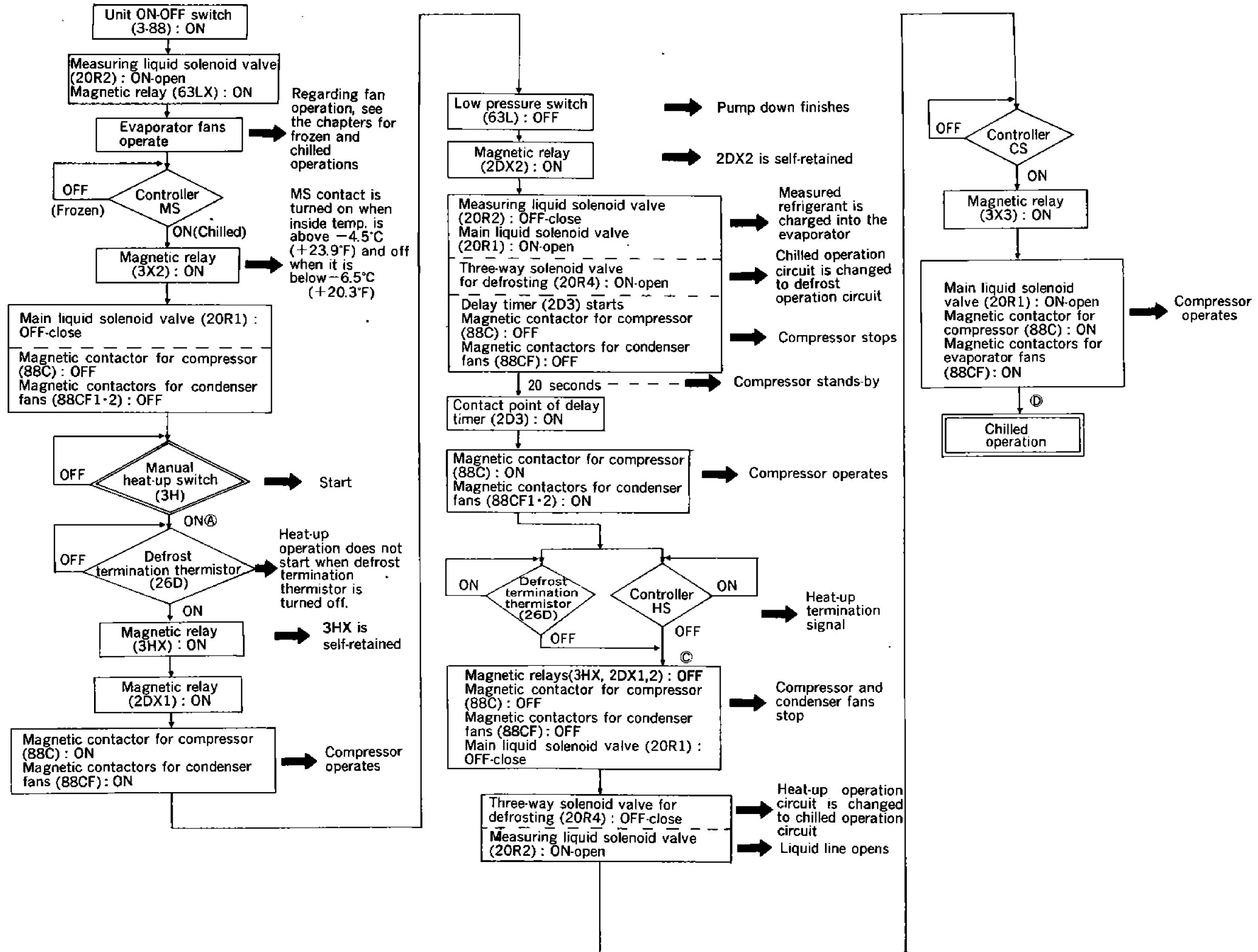

2.9 Refrigerant flow at each operation mode

● Frozen • chilled operation

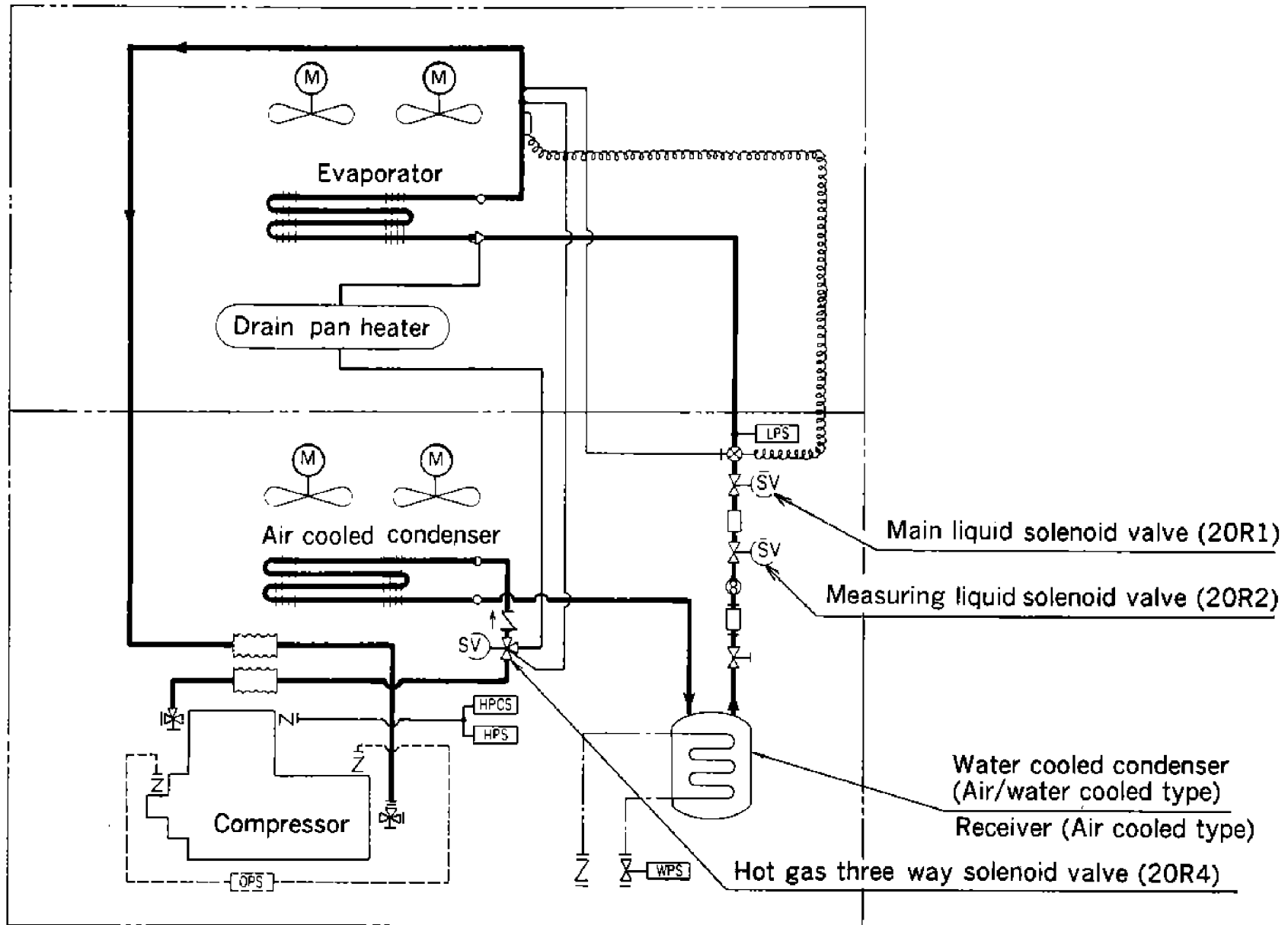

● Heat-up • defrost operation

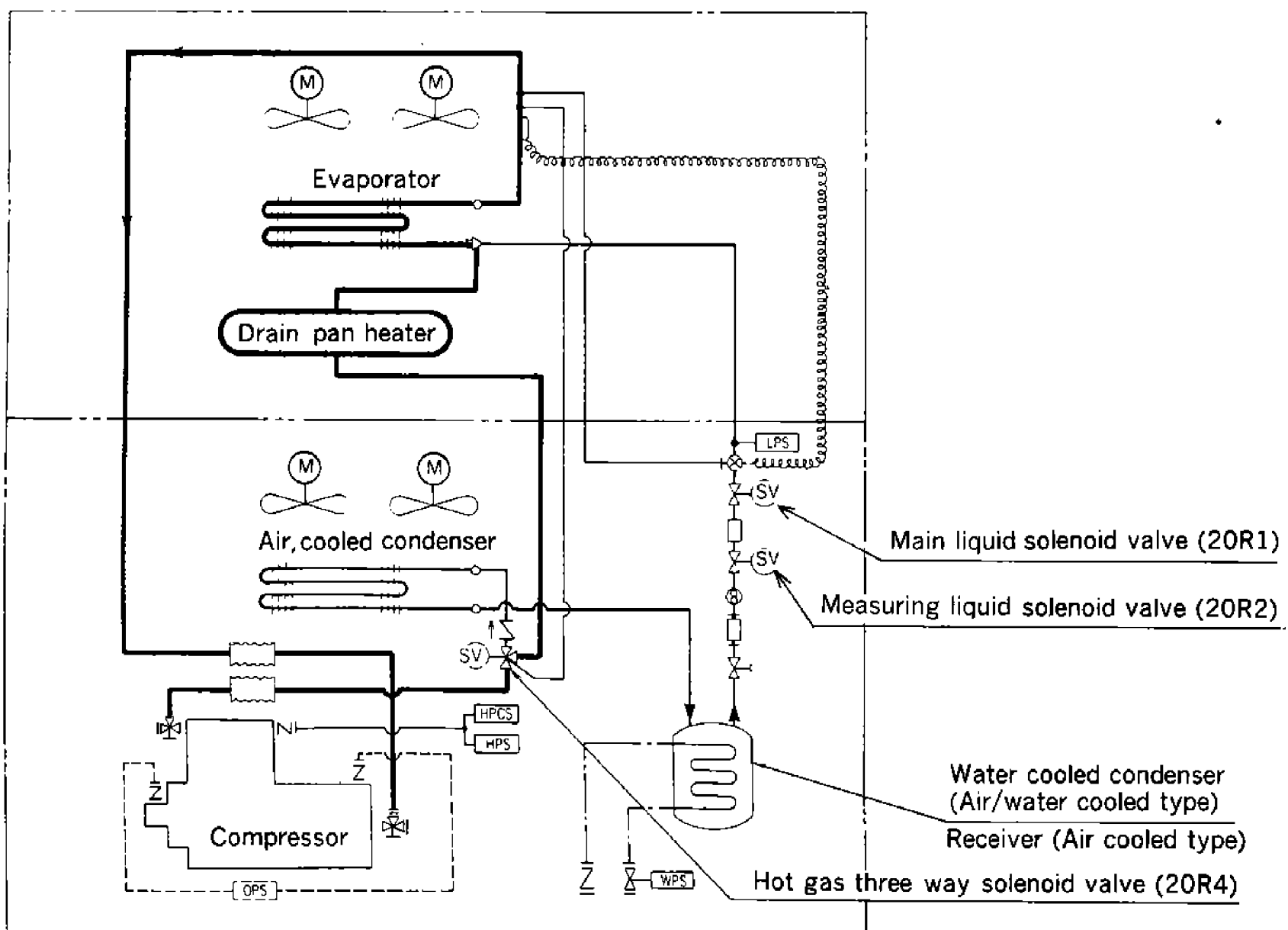

2.10 Pilot lamps and monitoring circuit

(1) Four lamps which indicate operating mode are mounted on the front panel of the control box.

Red : indicates defrost mode (RL)

Green : indicates that the compressor is running (GL)

Orange : indicates that inside temperature is with in range (Within $\pm 3.6^{\circ}\text{C}$ ($\pm 6.5^{\circ}\text{F}$) of the preset temperature) (OL)

White : indicates that electrical source is supplied.

Receptacle for monitoring is fitted and its connections is shown at below.

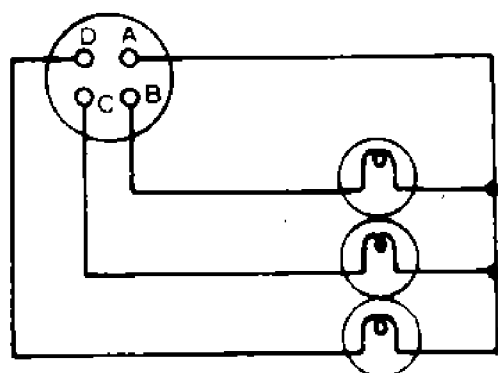

- A : Earth
- B : Compressor (Green)
- C : Defrost (Red)
- D : In range (Orange)

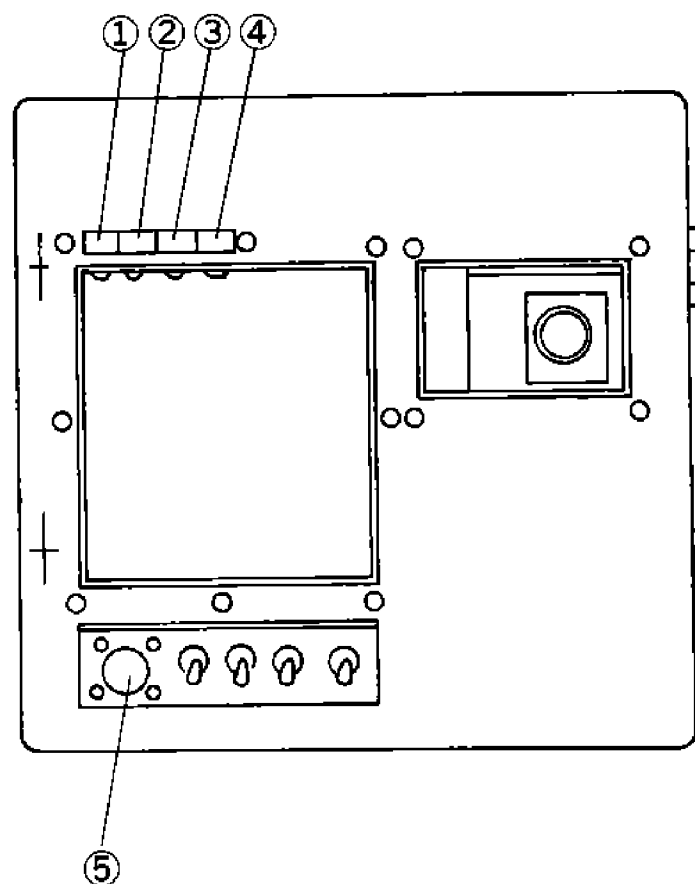

- ① Red
- ② Green
- ③ Orange
- ④ White
- ⑤ Monitoring receptacle for pilot lamp

(2) How to judge operation state by pilot lamps and function of the components.

| Parts Name | Setpoint selector set above -4.5°C ($+23.9^{\circ}\text{F}$) chilled mode | | | Setpoint selector set below -6.5°C ($+20.3^{\circ}\text{F}$) frozen mode | | Defrost operation | Water cooled operation (Air/water cooled type) | | |
|--------------------|---|----------|----------------------------|--|----------|-------------------|--|---|---|
| | Pull down | In range | Heat-up operation (manual) | Pull down | In range | | | | |
| pilot lamp | DEFROST—Red | × | × | × | × | ○ | Water cooled condition is the same as air cooled except ○ Water pressure switch (63W) opens ○ Condenser fan motor (MF2) de-energized ○ According to conditions, one of two condenser fan motors rotates even though water cooled operation. | | |
| | COMP—Green | ○ | ○ or × | ○ | ○ | ○ or × | | | |
| | IN RANGE—Orange | × | ○ | × | × | ○ | | | |
| | POWER—White | ○ | ○ | ○ | ○ | ○ | | | |
| Magnetic contactor | Compressor • Condenser fan motor (88C) | ○ | ○ or × | ○ | ○ | ○ or × | | ○ | |
| | Evaporator fan motor low speed (88EFL) | * ○ or × | * ○ or × | * ○ or × | ○ | ○ | | | × |
| | Evaporator fan motor high speed (88EFH) | * ○ or × | * ○ or × | * ○ or × | × | × | | | × |
| Solenoid valve | 20R1 | ○ | ○ or × | ○ | ○ | ○ or × | | ○ | |
| | 20R2 | ○ | ○ | × | ○ | ○ | | × | |
| | 20R4 | × | × | ○ | × | × | | ○ | |
| Compressor. MC | | ○ | ○ or × | ○ | ○ | ○ or × | ○ | | |

Notes 1) ○ : Energized or ON, × : De-energized or OFF

2) * Shows operation mode changes by supply air temperature

● Supply air temperature : above 20°C (68°F)

...low fan speed operation

● Supply air temperature : below 15°C (59°F)

...high fan speed operation

3. Trouble and countermeasures

If the unit does not work properly, inspect it in accordance with "Trouble and countermeasures" to find causes of trouble and provide appropriate countermeasures.

(1) LXE5A-C

LXE5A-CT

LXE5A-CA

LXE5A-CAT, LXE5-CAT(MFG. NO. 6800026~)

●Frozen, chilled operation

| State | Phenomena | Functioning places | Cause of trouble | Countermeasures |
|---|--|--|---|---|
| I. Unit does not operate. | A : Evaporator fans, condenser fans and compressor do not operate. | a. No trouble with unit | Electric interruption. | Trace causes of trouble. |
| | | | Power plug is not connected to power source receptacle. | Connect power plug to power source receptacle. |
| | | b. Circuit breaker (main circuit) functions | It functions with large current due to short circuit. | Trace causes of trouble |
| | | c. Circuit breaker (control circuit) functions | It functions with large current due to short circuit | Trace causes of trouble |
| | | d. Oil pressure protection switch is functioning.(Option) | It is left as it has functioned. | Repair trouble and set reset switch to on. |
| | | e. Compressor protective thermostat function. | Current is excessively large due to over-load operation. Open phase power supply circuit. | Trace causes of trouble. |
| | f. Controller malfunctions. | Sensor is damaged or other reasons. | Replace controller. | |
| | B : Evaporator fans operate. Condenser fans and compressor do not operate. | a. No trouble with unit | Controller functions to stop the unit. | — |
| | | | Setting of set-point selector is high | Adjust setting appropriately. |
| | C : Compressor only operates, but evaporator and condenser fans do not operate | a. Phase sequence controller does not function | Open phase power supply circuit. | Trace causes of trouble. |
| | | | Phase sequence controller is faulty. | Replace faulty phase sequence controller. |
| | II. Unit can operate but stops soon. | A : Evaporator fans, condenser fans and compressor do not operate. | a. Oil pressure protection switch is functioning.(Option) | Oil pressure will not rise. Oil is short or oil pump is out of order. |
| b. Compressor protective thermostat function. | | | Current is excessively large due to over-load operation. Open phase power supply circuit. | Trace causes of trouble. |
| B : Condenser fans and compressor stop, keeping evaporator fans in operation. | | a. Oil pressure protection switch is functioning.(Option) | Oil pressure will not rise. Oil is short or oil pump is out of order. | Additional oil charge, or repair oil pump. |
| | | b. No trouble with unit. | Controller functions and stops unit. | — |
| C : Condenser fans and compressor operate on and off. Evaporator fans continue operating. | | a. High pressure switch functions. | Refrigerant is over-charged. | Discharge refrigerant. |
| | | | Air is intermixed in refrigeration system. | Purge air |
| | | | Cooling air volume is short during air cooled operation. | — |
| | | | ● Condenser is clogged or air passages are blocked. | Clean condenser or remove obstacles |

| State | Phenomena | Functioning places | Cause of trouble | Countermeasures | |
|--|---|--|---|--|--|
| II. Unit can operate but stops soon. | C : Condenser fans and compressor operate on and off. Evaporator fans continue operating. | a. High pressure switch functions. | ● Fan blades are damaged. | Repair faulty fan blades or replace them. | |
| | | | ● Fan motor does not rotate. | Check electric wiring. | |
| | | | Fan motor protective thermostat functions. | Trace causes of trouble. | |
| | | | Cooling water is insufficient during water cooled operation. | — | |
| | | | ● Condenser is clogged with scale. | — | |
| | | b. Over-current relay and compressor protective thermostat function. | Current is excessively large due to over-load operation. Open phase power supply circuit. | Trace causes of trouble. | |
| II. Unit can operate but stops soon. | D : Condenser fans and compressor operate. Evaporator fans operate on and off. | a. No trouble with unit. | One minute stopping of fan after defrosting. | — | |
| | | b. Protective thermostat is activated. | Coil temperature rise due to overcurrent to fan motor. | Trace causes of trouble. | |
| III. Inside temp. is low than temperature setting | Compressor does not stop. (In frozen operation) | a. Controller does not function. | Sensor is disconnected | Replace sensor. | |
| | | b. Sensor is installed incorrectly. | — | Reattach sensor. | |
| IV. Inside temperature does not drop | Inside temperature does not reach to preset temperature. (Fans and compressor operate.) | a. Solenoid valve does not open. | Solenoid valve is clogged with dust. | Clean solenoid valve or remove obstacles. | |
| | | | b. Suction pressure is low. | Charged refrigerant volume is short. | Additionally charge refrigerant, find leaking points or repair them. |
| | | | | Dryer is clogged. | Replace dryer. |
| | | | | Choked with water. | Replace dryer. |
| | | | | Gas leaks from feeler tube of expansion valve. | Replace expansion valve. |
| Loosening of screws for connection of sensor. | Additional tightening of screws. | | | | |
| V. Water cooled operation is not performed (Air/water cooled type) | Fan continues running although water couplings are connected. | Water pressure switch does not function. | Cooling water becomes insufficient. (Piping system is clogged or leaks.) | Trace causes of trouble | |
| | | | Water leaks to switch | Repair leaking point. | |

●Defrost operation.

Read the sequence operation of each operation mode again. If operation does not accord with the sequence operation, take the necessary countermeasures in accordance with the following table.

The red and green pilot lamps light up during defrosting, and the green pilot lamp lights up during heating-up operation.

| State | Phenomena | Functioning places | Cause of trouble | Countermeasures | |
|---------------------------------------|---|--|---|--|---------------|
| I. Defrosting does not start. | A : Turn on manual defrost switch, but defrosting does not start. | a. No trouble with unit. | Compressor stops. | — | |
| | | b. Defrost termination thermistor does not close. | Defrost termination thermistor is faulty. | Replace defrost thermistor. | |
| | | c. controller does not function. | Controller is faulty. | Replace faulty controller. | |
| | B : Frozen operation continues for 13 hours or more. | Controller does not function. | Controller is faulty. | Replace faulty controller. | |
| II. Defrosting starts but stops soon. | Defrosting starts condenser fans, compressor stop soon. | a. No trouble with unit. | Unit stops for 20 seconds by timer. | — | |
| | | b. Liquid solenoid valves do not close. | Valves are clogged with dust. | Clean valves or remove obstacles. | |
| | | c. Low pressure switch is opening. | Low pressure switch is faulty, wire is disconnected. | Replace or repair. | |
| III. Defrosting time is too long. | A : It takes 90 minutes to defrost although frost collected is small. | a. No trouble with unit. | It takes time to defrost because of low ambient temp. | — | |
| | | b. Defrost termination thermistor does not open. | Defrost termination thermistor is faulty. | Replace defrost thermistor. | |
| | | c. Three way solenoid valve does not change to defrosting circuit. | Valve is clogged with dust. Three way solenoid valve is faulty. | Clean valve, remove obstacles or replace valve. | |
| | | d. Main liquid solenoid valve (2OR1) is not opened. | Low pressure switch is faulty. | Replace faulty low pressure switch. | |
| | B : Defrosting operation continues for 90 minutes or more. | | | Wrong wiring for measuring liquid solenoid valve (2OR2) and main liquid solenoid valve (2OR1). | Check wiring. |
| | | Controller does not function. | Controller is faulty. | Replace faulty controller. | |
| IV. Defrosting repeat every 4 hours. | | No trouble with unit. | Inside temperature is out of in range temperature. | — | |

●Heat up operation.

| State | Phenomena | Functioning places | Cause of trouble | Countermeasures |
|--|---|---|--|-----------------------------------|
| I. Heat up operation does not start. | Turn on manual heat up switch, but defrosting does not start. | a. No trouble with unit. | Temperature setting is lower than inside temperature. | — |
| | | b. Defrost termination thermistor does not close. | Defrost termination thermistor is faulty. | Replace defrost thermistor. |
| | | c. Controller does not function. | Controller is faulty. | Replace faulty controller. |
| II. Heat up operation starts but stops soon. | Heat up operation starts condenser fans, compressor stop soon, evaporator fans continue to operate. | a. No trouble with unit. | Unit stops for 20 seconds by timer. Inside temperature reaches to temperature setting, controller operates and unit stops. | — |
| | | b. Liquid solenoid valves do not close. | Valves are clogged with dust. | Clean valves or remove obstacles. |
| | | c. Low pressure switch is opening. | Low pressure switch is faulty, wire is disconnected. | Replace or repair. |

(2) LXE5-C (MFG. NO. 6700001~6800052)
 LXE5-CAT (MFG. NO. 6700001~6700025)
 ●Frozen, chilled operation

| State | Phenomena | Functioning places | Cause of trouble | Countermeasures | |
|--|---|---|---|--|---|
| I. Unit does not operate. | A : Evaporator fans, condenser fans and compressor do not operate. | a. No trouble with unit | Electric interruption. Power plug is not connected to power source receptacle. | Trace causes of trouble. Connect power plug to power source receptacle. | |
| | | b. Circuit breaker (main circuit) functions | It functions with large current due to short circuit. | Trace causes of trouble | |
| | | c. Circuit breaker (control circuit) functions | It functions with large current due to short circuit | Trace causes of trouble | |
| | | d. Oil pressure protection switch is functioning.(Option) | It is left as it has functioned. | Repair trouble and set reset switch to on. | |
| | | e. Controller malfunctions. | Sensor is damaged or other reasons. | Replace controller. | |
| | B : Evaporator fans operate. Condenser fans and compressor do not operate. | a. No trouble with unit | Controller functions to stop the unit. Setting of set-point selector is high | — Adjust setting appropriately. | |
| | | C : Compressor only operates, but evaporator and condenser fans do not operate | a. Phase sequence controller does not function | Open phase power supply circuit. Phase sequence controller is faulty. | Trace causes of trouble. Replace faulty phase sequence controller. |
| | II. Unit can operate but stops soon. | A : Condenser fans and compressor stop, keeping evaporator fans in operation. | a. Oil pressure protection switch is functioning.(Option) | Oil pressure will not rise. Oil is short or oil pump is out of order. | Additional oil charge, or repair oil pump. |
| | | | b. No trouble with unit | Controller functions and stops unit. | — |
| | | B : Condenser fans and compressor operate on and off. Evaporator fans continue operating. | a. High pressure switch functions. | Refrigerant is over-charged. | Discharge refrigerant. |
| Air is intermixed in refrigeration system. | | | | Purge air | |
| Cooling air volume is short during air cooled operation. | | | | — | |
| ● Condenser is clogged or air passages are blocked. | | | | Clean condenser or remove obstacles | |
| ● Fan blades are damaged. | | | | Repair faulty fan blades or replace them. | |
| ● Fan motor does not rotate. | | | | Check electric wiring. | |
| Fan motor protective thermostat functions. | | | | Trace causes of trouble. | |
| Cooling water is insufficient during water cooled operation. | | | | — | |
| ● Condenser is clogged with scale. | — | | | | |
| b. Over-current relay and compressor protective thermostat function. | Current is excessively large due to over-load operation. Open phase power supply circuit. | Trace causes of trouble. | | | |

| State | Phenomena | Functioning places | Cause of trouble | Countermeasures |
|--|---|--|--|--|
| II. Unit can operate but stops soon. | C : Condenser fans and compressor operate. Evaporator fans operate on and off. | a. No trouble with unit. | One minute stopping of fan after defrosting. | — |
| | | b. Protective thermostat is activated. | Coil temperature rise due to overcurrent to fan motor. | Trace causes of trouble. |
| III. Inside temp. is low than temperature setting | Compressor does not stop. (In frozen operation) | a. Controller does not function. | Sensor is disconnected | Replace sensor. |
| | | b. Sensor is installed incorrectly. | — | Reattach sensor. |
| IV. Inside temperature does not drop | Inside temperature does not reach to preset temperature. (Fans and compressor operate.) | a. Solenoid valve does not open. | Solenoid valve is clogged with dust. | Clean solenoid valve or remove obstacles. |
| | | b. Suction pressure is low. | Charged refrigerant volume is short. | Additionally charge refrigerant, find leaking points or repair them. |
| | | | Dryer is clogged. | Replace dryer. |
| | | | Choked with water. | Replace dryer. |
| | | | Gas leaks from feeler tube of expansion valve. | Replace expansion valve. |
| Loosening of screws for connection of sensor. | Additional tightening of screws. | | | |
| V. Water cooled operation is not performed (Air/water cooled type) | Fan continues running although water couplings are connected. | Water pressure switch does not function. | Cooling water becomes insufficient. (Piping system is clogged or leaks.) | Trace causes of trouble |
| | | | Water leaks to switch | Repair leaking point. |

● **Defrosting and heating-up operation.**

Read the sequence operation of each operation mode again. If operation does not accord with the sequence operation, take the necessary countermeasures in accordance with the following table.

The red and green pilot lamps light up during defrosting, and the green pilot lamp lights up during heating-up operation.

| Phenomena | Functioning places | Causes of trouble | Countermeasures |
|--|--|--|---|
| Compressor stops soon after starting defrosting (heating-up). | No trouble with unit. | Unit stops for 20 seconds by timer. | — |
| Compressor operates on and off. | High pressure switch function. | Measuring liquid solenoid valve (20R2) is not closed. | Clean solenoid valve or remove obstacles. |
| Compressor continues to evacuate for 90 minutes. | Main liquid solenoid valve (20R1) is not opened. | Low pressure switch is faulty. | Replace faulty low pressure switch. |
| | | Wrong wiring for measuring liquid solenoid valve (20R2) and main liquid solenoid valve (20R1). | Check wiring. |
| It takes 90 minutes to defrost although frost collected is small. | No trouble with unit. | It takes time to defrost because of low ambient temp. | — |
| | Defrost termination thermistor does not open. | Defrost termination thermistor is faulty. | Replace defrost thermistor. |
| Frozen operation continues for 13 hours or more and defrosting will not start. | Controller does not function. | Controller is faulty. | Replace faulty controller. |
| Defrost and frozen operation repeat every 4 hours. | No trouble with unit. | Inside temperature is out of in range temperature. | — |

4. PTI (Pri Trip Inspection)

To keep the unit in good operating condition, check adjust or repair the unit when necessary. The following is the checking items of PTI (an example of container refrigeration unit checklist).

| Container refrigeration unit inspection card | | | | DAIKIN INDUSTRIES, LTD. | | |
|--|-----|---|---|--|---|---|
| Installed ship name | | | | Date of inspection | | |
| Container No. | | | | Place of inspection | | |
| Loaded cargo | | | | Unit Model No. | | |
| Customer's staff | | | | Unit No. | | |
| Service staff | | | | Compressor No. | | |
| Check | No. | Check point | Check method | Reference value | | |
| | 1 | External appearance of important parts of container (doors, equipment mount, damaged points) | Visual | | | |
| | 2 | Cleaning interior and exterior of container | Visual | | | |
| | 3 | Checking the smudge of the unit (air-cooled condenser, evaporator) | Visual | | | |
| | 4 | Checking penetration between inside and outside of unit | Visual | | | |
| | 5 | Checking leakage of gas and oil on refrigerant circuit (mainly at joints) | Halide torch | | | |
| | 6 | Checking external appearance of power cable and plug | Visual | | | |
| | 7 | Cleaning drain hose | Visual | Shall be free from clogging | | |
| | 8 | Cleaning defrost air hose and checking that there is no trap on it, (option) | Visual | Shall be free from clogging | | |
| | 9 | Checking operation of heat-up function | Check operation | | | |
| | 10 | Checking appearance of defrost termination thermostat | Visual | | | |
| | 11 | Tightened condition of cable glands and monitoring receptacle | Retighten with tool | Make sure that they are firmly tightened | | |
| | 12 | Checking condenser and evaporator fan motors for vibration and noise | Touch and listen | | | |
| | 13 | Checking seal of liquid indicator | Check liquid indicator | Make sure that it is sealed | | |
| | 14 | Checking for water in refrigerant | Check liquid indicator | Dry indication | | |
| | 15 | Checking compressor oil level (operating condition) | Check compressor oil level gauge | ☉ (oil level 1/4 ~ 3/4) | | |
| | 16 | Checking operation and battery of recorder | Visual | | | |
| | 17 | Checking operation of each solenoid valve | Listen or touch each tube | | | |
| | 18 | Checking operation of controller and pilot lamps | Refer check instrument | | | |
| | 19 | Checking operation of defrost initiation air switch (option) | Check with U tube | mmH ₂ O GUTIN | | |
| | 20 | Unit operating current R <input type="checkbox"/> S <input type="checkbox"/> T <input type="checkbox"/> | Clamp meter | -18°C <input type="checkbox"/> V <input type="checkbox"/> Hz | | |
| | 21 | Unit insulation resistance | Compressor circuit <input type="checkbox"/> MΩ | DC 500V megger | 2MΩ or more | |
| | | Evaporator fan circuit <input type="checkbox"/> MΩ | | | | |
| | 22 | Checking manual defrosting operation | Manual defrost switch | | | |
| | 23 | Checking operation of defrost termination thermostat (Completing temperature) <input type="checkbox"/> °C | Mount thermistor to completion thermostat mounting position | OFF 40~ 60°C | | |
| | 24 | Checking operation of high pressure control switch | Visual left side air cooled condenser fan to be stopped | | | |
| | 25 | Checking operation of high pressure switch | H-CUT OUT <input type="checkbox"/> kg/cm ² | Operate the air cooled condenser without fan operation | 20 Kg/cm ² | |
| | | H-CUT IN <input type="checkbox"/> kg/cm ² | 16.5 Kg/cm ² | | | |
| | 25 | Checking operation of low pressure switch | L-CUT OUT <input type="checkbox"/> mmHgV | Accomplish pump down by use of the stop valve at the water cooled condenser outlet | 400 mmHgV | |
| | | | L-CUT IN <input type="checkbox"/> kg/cm ² | | 0.2 Kg/cm ² | |
| | 26 | Checking operation of water pressure switch | Checking switchover from air cooled to water cooled operation | Disconnect water coupling | Condenser fan motor shall operate | |
| | | | Checking switchover from air-cooled to water-cooled operation | Connect water coupling and supply water | Condenser fan motor shall stop | |
| | 27 | Checking power supply changeover switch | Checking 200V class operation | Place changeover switch lever upward | | |
| | | | Checking 400V class operation | Place changeover switch lever downward | | |
| | 28 | Storage temperature °C | <input type="checkbox"/> | 0°C | -18°C | Automatic operation at -18°C |
| | | Ambient temperature °C | <input type="checkbox"/> | <input type="checkbox"/> | <input type="checkbox"/> | <input type="checkbox"/> in one cycle |
| | | LP kg/cm ² | <input type="checkbox"/> | <input type="checkbox"/> | <input type="checkbox"/> | COMP OFF <input type="checkbox"/> M |
| | | HP kg/cm ² | <input type="checkbox"/> | <input type="checkbox"/> | <input type="checkbox"/> | COMP ON <input type="checkbox"/> M |
| | | Operating time | Immediately after operation | Operation starting -- 0°C <input type="checkbox"/> Hr <input type="checkbox"/> M | Operation -- -18°C <input type="checkbox"/> Hr <input type="checkbox"/> M | Automatic operation at -18°C <input type="checkbox"/> Hr <input type="checkbox"/> M |
| | | | Operation starting time <input type="checkbox"/> <input type="checkbox"/> | | | |
| | 29 | Checking automatic defrosting operation | Defrost time <input type="checkbox"/> M | | | |

5. Major components and maintenance

5.1 Components related with refrigeration circuit

5.1.1 Compressor

The compressor is of a semi-hermetic type with the built-in motor so that there are few places where leakage of refrigerant may occur. The reversible trochoid pump used produces the required oil pressure regardless of the direction of rotation of the built-in motor.

① Replacement

Remove the compressor by the following procedure.

- 1) Remove the front and base plates and protective stay of the cable stowage.
- 2) Remove the discharge stop valve, suction stop valve gauge piping flare nut (compressor side) and cable.
- 3) Remove four bolts (two on each side) fastening the compressor and base.
- 4) Take out the compressor to the front of the unit.

② Installing procedure

Install the compressor according to reverse procedure given above. When tightening the bolts, refer to the list for torque.

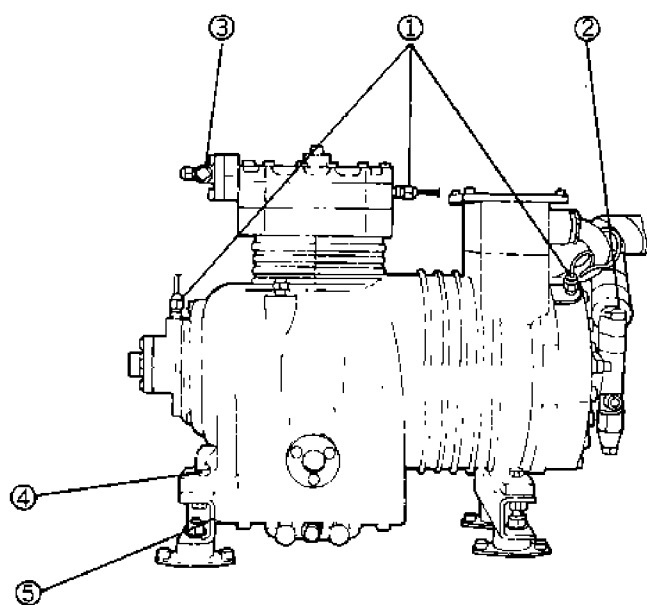

- ① Gauge piping flare nut
- ② Companion flange for compressor suction side
- ③ Stop valve at compressor discharge side
- ④ Bolt
- ⑤ Base

| | | | |
|----------------------------|------------------------------|-------------|----------|
| Tightening torque of bolts | Compressor | kg·cm/lb·ft | 435/36 |
| | Compressor stop valve flange | | 255/21 |
| | Fan motor | | 30/2.3 |
| | Solenoid valve | | 250/20.5 |
| | Expansion valve | | 55/4.3 |
| | Fan • Access panel | | |

Note : Allowable range of tightening torque $\pm 10\%$

5.1.2 Air cooled condenser and evaporator

Of the "cross fin" coil type having special corrugated fins are compact and very efficient in producing uniform heat exchange efficiency.

Maintenance

Service the air cooled condenser after removing the front panel. Service the evaporator after removing the access panels from outside.



Air cooled condenser

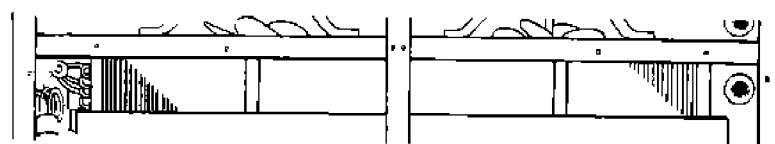

Evaporator

5.1.3 Water cooled condenser (Air/water cooled type)

Receiver (Air cooled type)

The water cooled condenser is mounted in case of the air/water cooled type and the receiver is installed in case of the air cooled type. Since the condenser is of the shell and coil type, cooling water flows in the inner cooling tubing and the refrigerant flows in the condenser shell. The cooling tubing having special fins are used to make it light and compact.

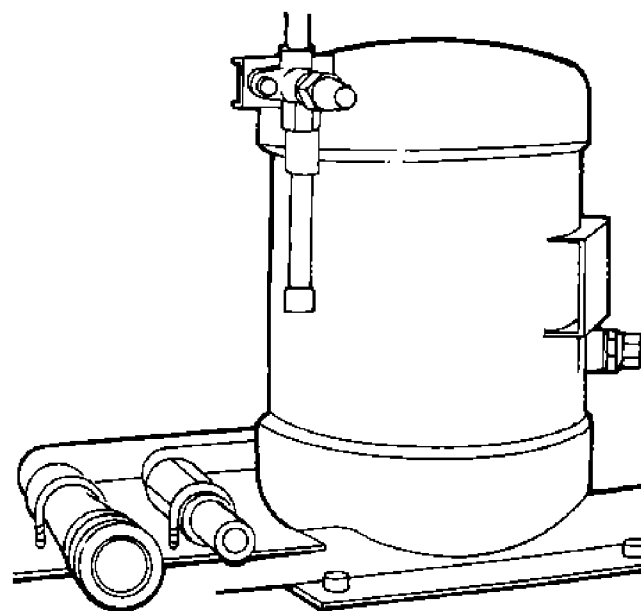

Replacement procedure of the fusible safety plug

When pressure rises abnormally in the system, the fusible plug melts itself, so if the fusible plug is melted check possible causes thoroughly.

When fusible plug functions, the centre of the fusible plug alloy ② melts, from which the refrigerant jets out. When the flare nut is removed, ① is apt to come out by pressure and clogs the passage of the refrigerant outlet, which prevents the refrigerant from jetting out and also the air from entering. Thus, refrigerant loss is extremely minimized.

Insert a new ② with ③, and tighten the flare nut.

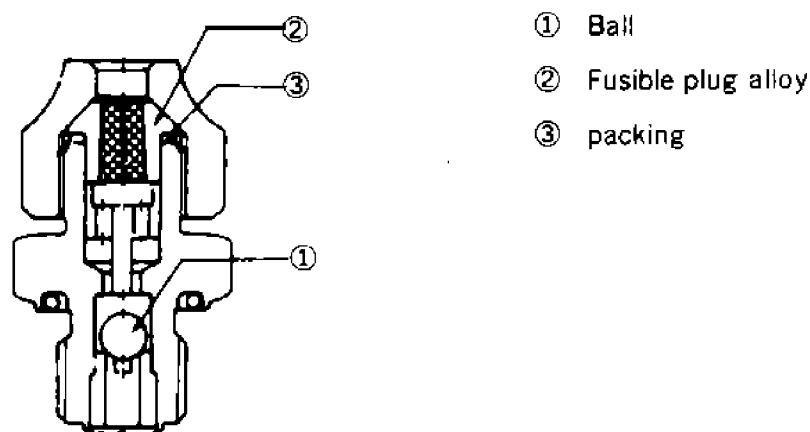

- ① Ball
- ② Fusible plug alloy
- ③ packing

Construction of fusible safety plug

5.1.4 Expansion valve

The externally equalized thermal expansion valve which is fitted before the evaporator and senses super-heat degree of leaving evaporator refrigerant and controls flow of the refrigerant automatically according to operating conditions. The expansion valve with MOP. (MAXIMUM OPERATING PRESSURE) is adopted to protect the compressor motor from overload.

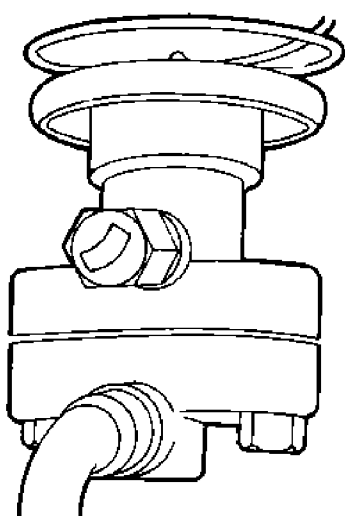

"CAUTION" Whenever adjusting and replacing the expansion valve, the unit should be stopped securely for safety sake.

① Adjusting the expansion valve

There are two methods to adjust the expansion valve; i.e, one is the adjustment based on the suction operation standard and the other is that based on the frost conditions on the compressor.



a. Adjustment based on the suction operation pressure

- 1) Confirm that the predesigned volume of the refrigerant has been charged.
- 2) Attach a pressure gauge to each gauge port and operate the refrigeration unit, maintaining inside temperature at $-18^{\circ}\text{C}(-0.4^{\circ}\text{F})$. (refer to "Maintenance").
- 3) When inside temperature comes to the preset temperature, compare the suction pressure reading with the standard pressure. (refer to "Standard operation pressure curve")
- 4) If suction pressure reading differs with the standard pressure, adjust the expansion valve as stated below.
- 5) After loosening the clamp screw, turn the adjusting screw.
- 6) Note that pressure will not change after a certain lapse of time.

b. The adjustment based on frost stated on the compressor.

- 1) Refer to the caution for adjustment of expansion valve as above. At this time, inside temperature should be maintained to $-18^{\circ}\text{C}(-0.4^{\circ}\text{F})$.
- 2) Regulate the adjusting screw as stated below based on frost state on the suction pipe and the stop valve of the compressor.
- 3) Whether or not the adjustment required is judged by frost state of the flange on the suction side of the suction valve.
- 4) However note that frost state differs with outdoor air conditions (temperature and humidity).

c. Adjusting points for expansion valve

- Suction pressure is higher than the standard pressure (Frost forms on the compressor side rather than the suction flange of the stop valve). Clockwise rotation of the adjusting screw decreases running pressure. 
- Suction pressure is lower than the standard pressure (Frost forms on the suction pipe rather than the suction flange of the stop valve). Counterclockwise rotation of the adjusting screw increases running pressure. 

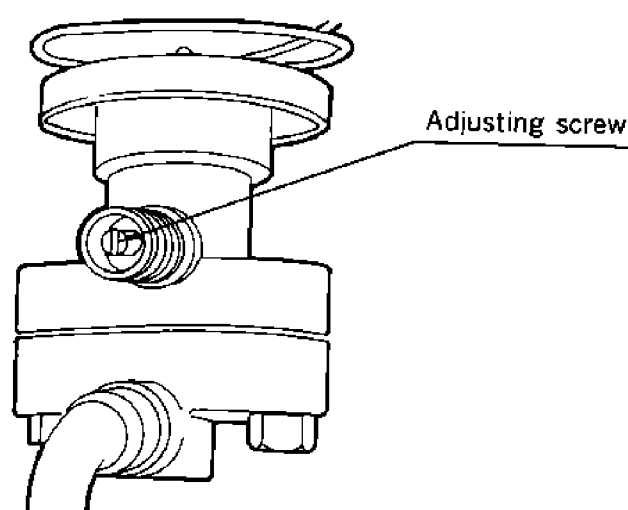

d. Countermeasures after operation

- 1) Remember the original setting of the expansion valve. If any change is found with the setting after adjustment of the expansion valve, return the adjusting screw to the original position, as trouble occurred caused by other reasons.
- 2) When the adjusting screw is returned to its original position, firstly turn it passing the original position and then return it to the original position.
- 3) After adjustment, be sure to tighten up the clamp screw and cap it to prevent the refrigerant from leaking.
- 4) After completion of the adjustment, operate the unit, keeping inside temperature at $-18^{\circ}\text{C}(-0.4^{\circ}\text{F})$ and confirm that low pressure does not go down below standard operation pressure

② **Replacement**

Remove the access panel, the front panel of the air cooled condenser fan and fan guide which are located outdoors, before undertaking the work.

- 1) Remove the feeler tube, equalizing pipe flare, and fastening bolts. (To replace the cage alone, there is no need to remove the feeler tube.)
- 2) Remove the power assembly, cage, and packing.
- 3) Be sure to install a new packing when replacing it.

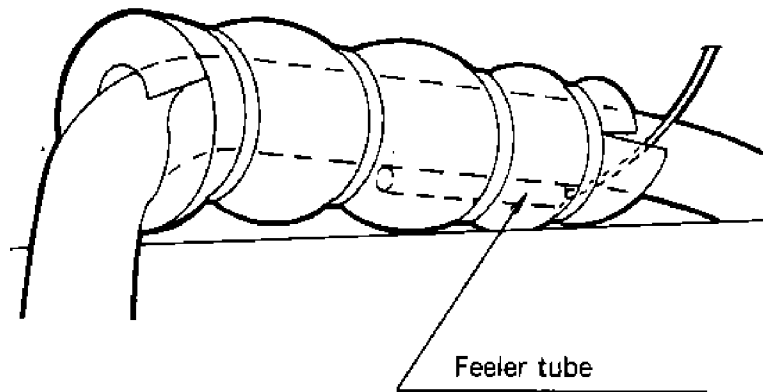

5.1.5 Liquid/moisture indicator

This indicator permits checking of flow of the refrigerant and moisture content in the refrigerant.

① **Moisture content**

- The indicator indicates moisture content by the color at the center of the window.

Check this indicator during the unit is operating.

| Color | State |
|-----------|--------------------------|
| Deep blue | Dry |
| Orange | Wet (moisture contained) |

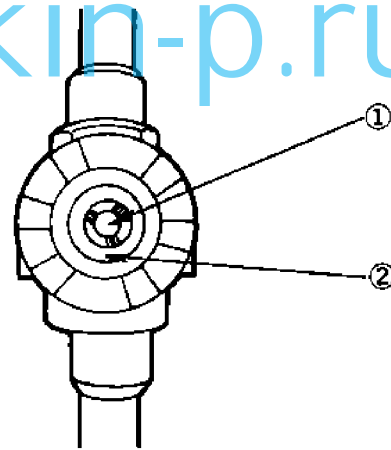

- ① Moisture indicator
- ② Corrugated glass

- Note:**
1. The indicator may appear orange if it has been exposed to gaseous refrigerant for a long time.
 2. The indicator is to be checked at being sealed with liquid refrigerant after operating for a few hours.
 3. Change of the indicator is influenced by the temperature of liquid refrigerant. The lower temperature cause the change of indicator to take the longer time.
 4. To shorten the time for change of indicator, raise up the temperature of liquid refrigerant.

② **Flow of the refrigerant**

- When the liquid refrigerant is sealed, corrugation on the sight glass disappears.
- Check

| Operation | Indicator state |
|------------------|--|
| At start | Bubbles appear but liquid refrigerant is sealed in 30 minutes to an hour after starting. |
| During operation | Bubbles may appear more or less. |

If bubbles develop continuously, the refrigerant is possibly running short.

③ **Replacement**

- 1) Put the system in "pump down" state.
- 2) Turn the sight glass counterclockwise, and remove it together with the O-ring.
- 3) Apply refrigeration oil to the new O-ring, and fasten the sight glass with torque of 70 ± 5 kg-cm. (Do not apply excessive torque, or the O-ring will break.)

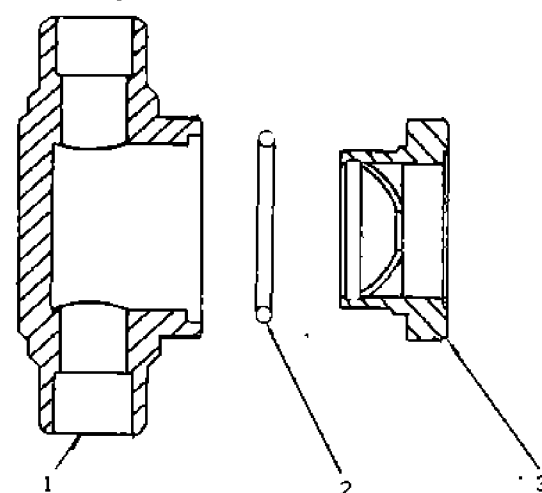

- ① Body
- ② O-ring
- ③ Sight glass

5.1.6 Dryer

This removes moisture and dust from the refrigerant while it is circulated. Replace the dryer if it does not remove moisture or is clogged.

When installing the new dryer, follow the directions given on the nameplate and do not make any mistake about the direction of the dryer.

Replacement

- 1) In "pump down" state (refer to "Maintenance"), close the compressor suction stop valve.
- 2) Then, loosen the flares (the flange bolts) at the both end of the dryer and replace the dryer quickly.
- 3) Be careful not to get air into the piping on the solenoid valve side while removing the dryer.
- 4) After reattachment of the dryer, open the stop valve a little to purge the air in the dryer from the flare (flange) on the solenoid valve side and then close it at once.
- 5) Loosen the flare (the flange bolt) on the other side, turn on the unit ON/OFF switch and open the solenoid valve only to purge the air.
- 6) After completion of the work, open the stop valves to its original state and then inspect the system for gas leakage. Confirm no gas leakage is found.

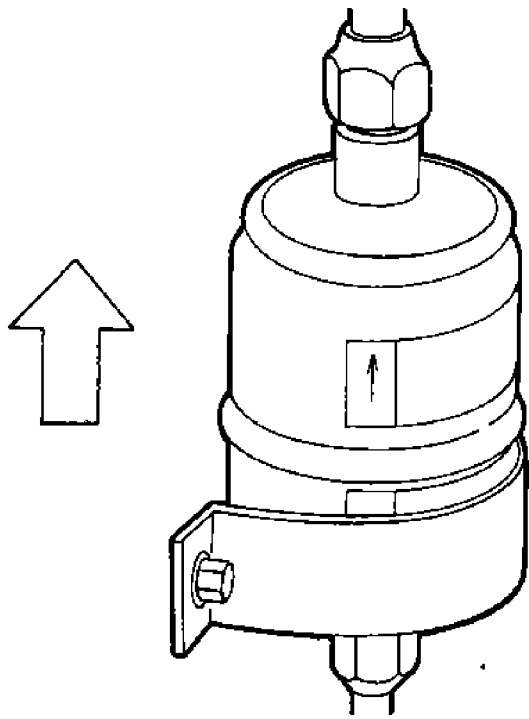

5.1.7 Solenoid valves

① Solenoid valves in the liquid line (20R1, 2)

20R1, 2 are opened or closed by the signal of the controller.

When 20R1, 2 are closed, the refrigerant flow is blocked.

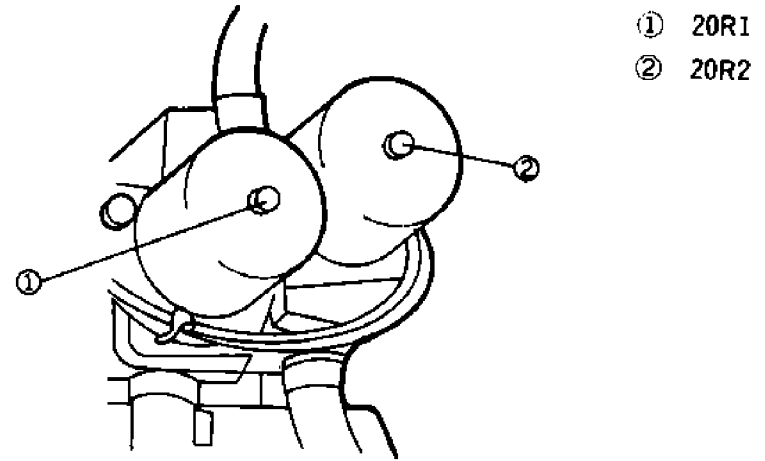

- ① 20R1
- ② 20R2

Disassembly

- 1) The structure of the solenoid valve is shown at right. (For disassembly, checking, and reassembly, refer to this diagram.)
- 2) When brazing a pipe to the valve, cool the valve body with a wet cloth. (It is not required to disassemble the valve. Remove the coil ass'y from the body.)
- 3) During reassembly, tighten the four bolts×4 with torque of 50–60 kg-cm.

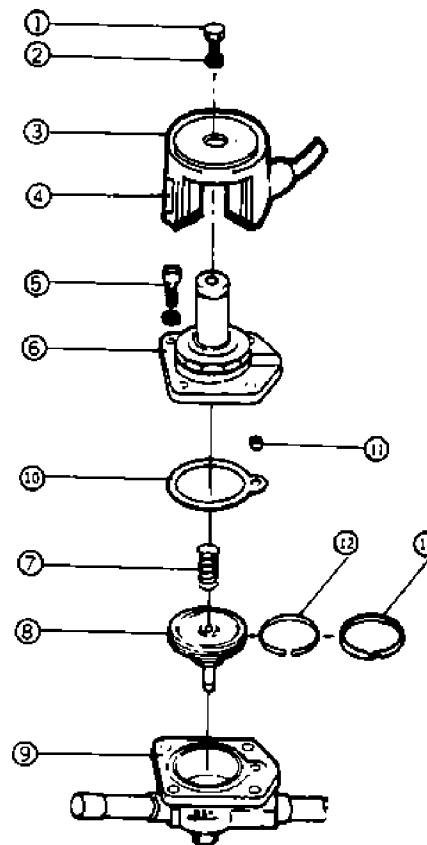

| No. | Parts name |
|-----|-------------------------|
| ① | Set bolt (M5) |
| ② | Spring lock washer (M5) |
| ③ | Name plate |
| ④ | Coil ass'y |
| ⑤ | Set bolt |
| ⑥ | Cover ass'y |
| ⑦ | Spring |
| ⑧ | Piston |
| ⑨ | Valve body |
| ⑩ | Packing |
| ⑪ | Sleeve |
| ⑫ | Inner ring |
| ⑬ | Piston ring |

② **3 way solenoid valve for defrosting (20R4)**

● Model: DHV804DXF

● Power supply: AC 24V, 50/60Hz

The 3 way solenoid valve is provided to change the discharge gas flow to the condenser during frozen operation to the evaporator during defrosting.

a. Piping connection

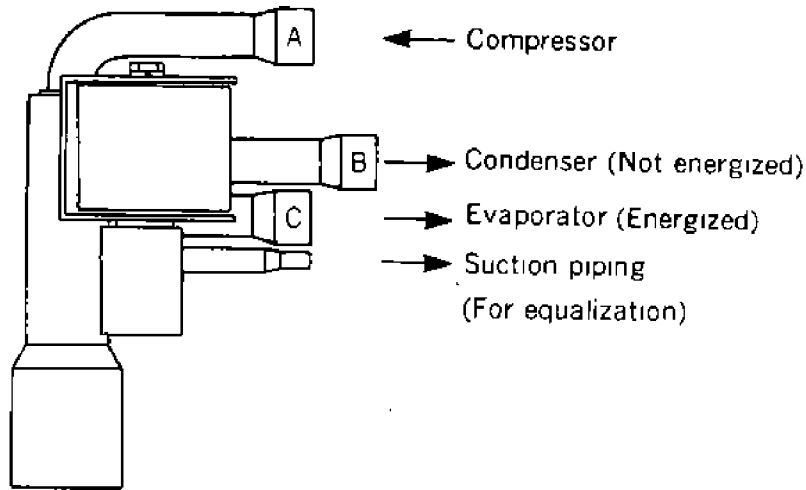

b. Replacing method

(1) Replacement of coil

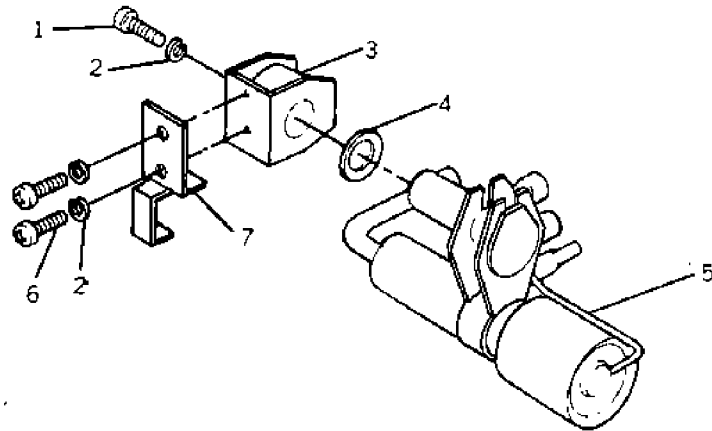

| No. | Parts name |
|-----|-------------------------|
| ① | Set bolt (M4) |
| ② | Spring lock washer (M4) |
| ③ | Coil |
| ④ | Washer |
| ⑤ | Valve body |
| ⑥ | Set screw (M4) |
| ⑦ | Bracket |

(2) Replacement of valve body

Before brazing the valve body, remove the coil and braze it while cooling it sufficiently (below 120°C [248°F]) with water-moistened cloth.

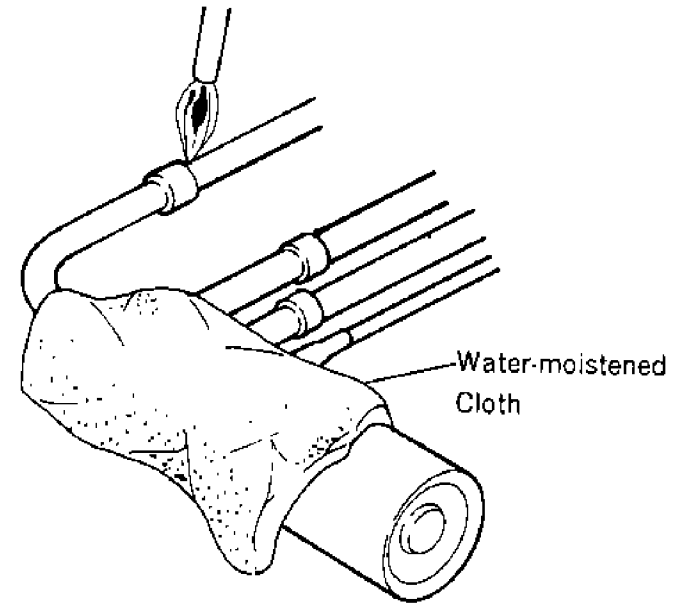

5.1.8 Check valve

During hot-gas defrost and heat-up operation, the refrigerant in the condenser flows reversely to prevent against over-loading caused by excessive refrigerant.

Replacing points

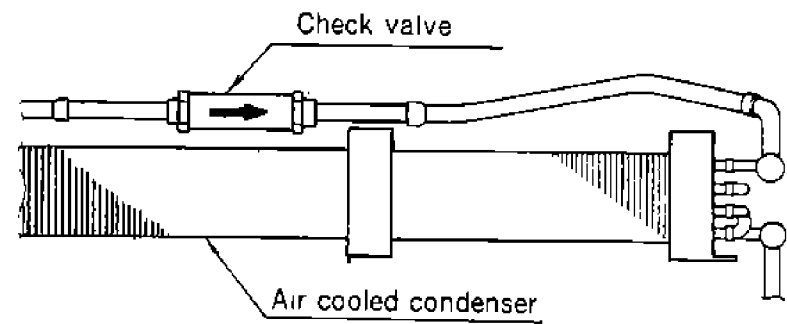

Note the direction of a check valve when it is replaced in accordance with the arrow mark on the nameplate. Braze it while cooling it sufficiently with water-moistened cloth.

5.2 Components related with the air system

5.2.1 Fans and motors

① Specifications

| | | Evaporator | Condenser |
|-------|-----------------------------|--|-------------|
| Fan | Type | Propeller fan | |
| | Numbers of blades | 6 pcs. | |
| | Blade diameter | φ285 | φ280 |
| Motor | Type | 3 phase squirrel-cage induction motor | |
| | Motor output (Pole numbers) | 250/400W(2P) 30/50W(4P) | 75/110W(4P) |
| | Bearing | Ball bearing, 6203 Non-contacting type Rubber seal | |

② Installation procedure

a. Evaporator fan and motor

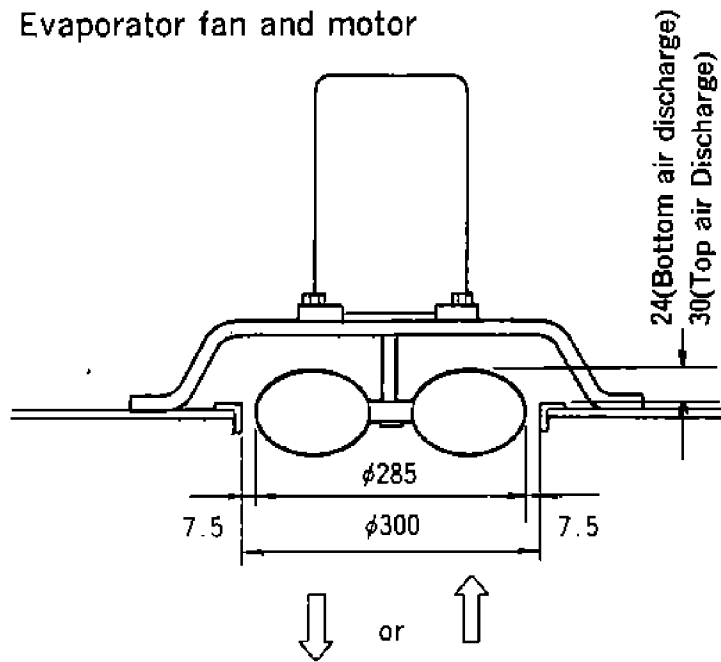

b. Condenser fan and motor

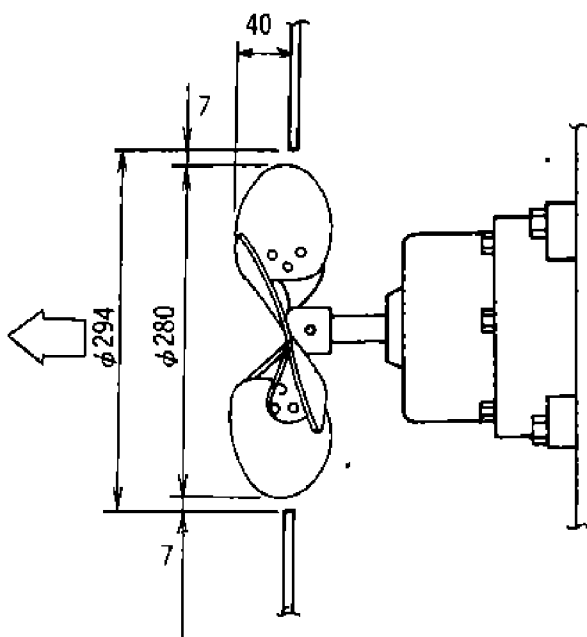

③ Replacing method for evaporator fan

Before removing the evaporator fan, loosen the bolts on the fan motor and remove the motor.

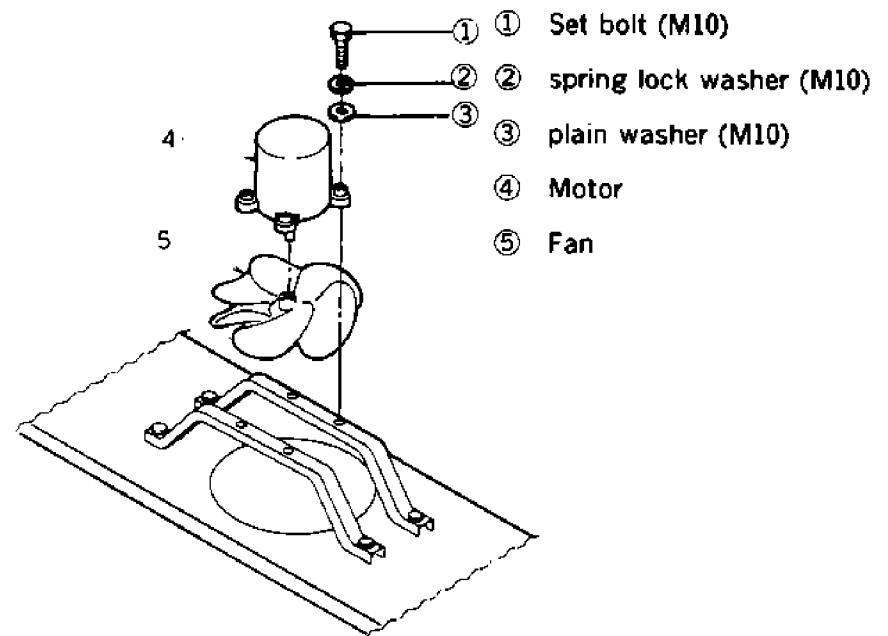

5.2.2 Ventilator

Handling method

- 1) In case ventilation is not needed:
Set the handle to "CLOSE".

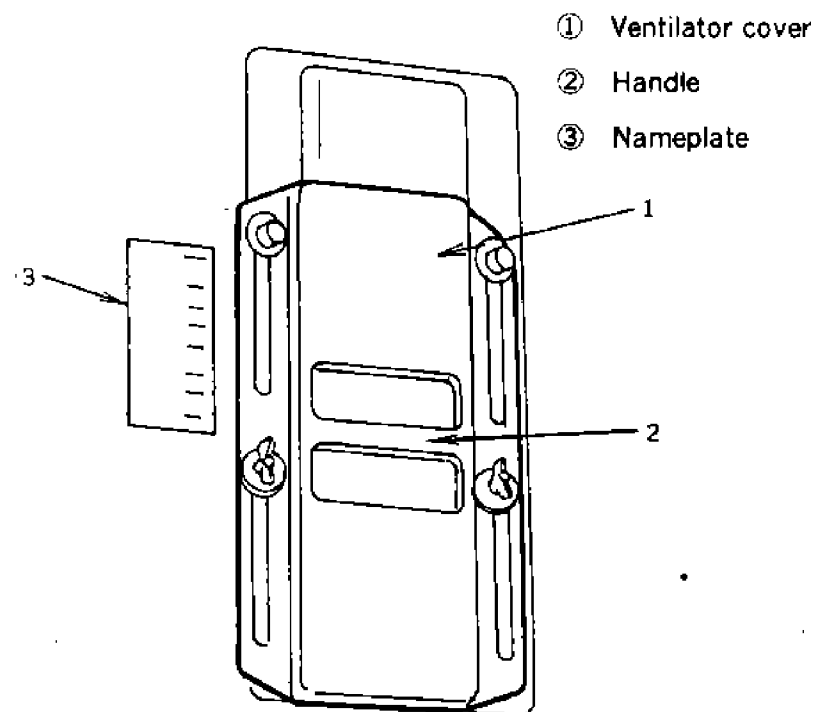

- 2) In case ventilation is needed:
Set the handle to "FULL OPEN".

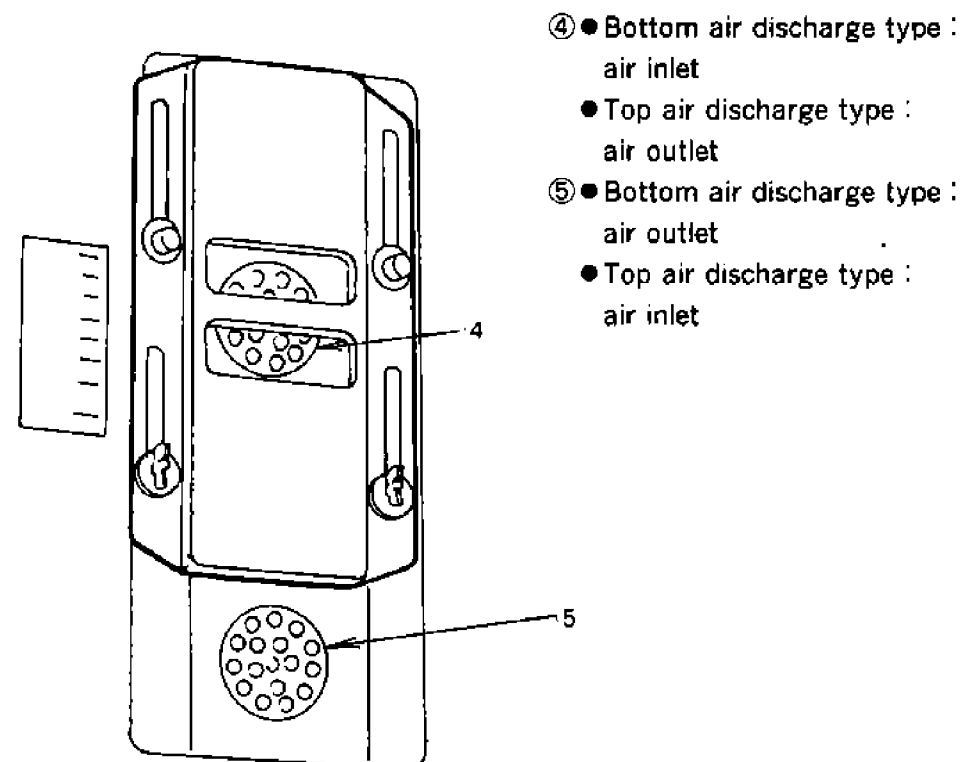

- ④ ● Bottom air discharge type :
air inlet
- Top air discharge type :
air outlet
- ⑤ ● Bottom air discharge type :
air outlet
- Top air discharge type :
air inlet

5.3 Functional electric parts

5.3.1 High pressure switch (63H1)

This switch causes compressor to stop, as the operation pressure of the unit has risen abnormally. Thus HPS is adapted to stop the compressor if the high pressure has gone up above its set value due to failure of condenser fan, obstructive passage to cooling water, etc.

5.3.2 Low pressure switch (63L)

When low pressure is lower than the predesigned value due to measured pump-down during defrosting or heat-up operation, this switch switches over the solenoid valve, detecting termination of measuring.

5.3.3 High pressure control switch (63H2)

If the ambient temperature is low during air cooled operation, one out of two condenser fans are turned off so that the high pressure should not fall. (As for more details, refer to "high pressure control")

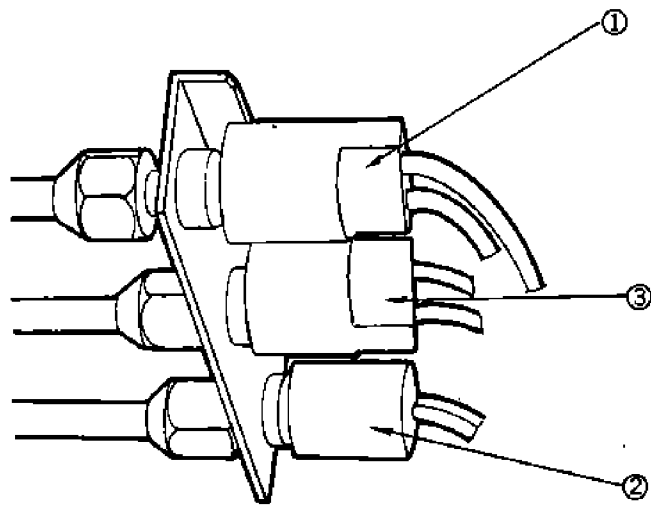

- ① High pressure switch (63H1)
- ② Low pressure switch (63L)
- ③ High pressure control switch (63H2)

5.3.4 Water pressure switch (63W)

(Air/water cooled type)

This switches over air and water cooled type. If cooling water flows and water pressure rises above a preset water pressure at the inlet, the contact is turned off to stop the condenser fan motor and water cooled operation will start.

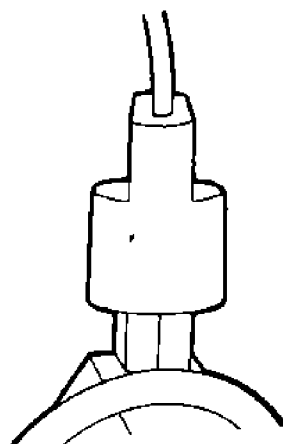

5.3.5 Oil pressure protection switch(63QL) (Option)

Oil pressure (difference between oil pressure and low pressure) falls due to oil pump failure, clogging and oil foaming.

This stops the compressor automatically when oil pressure continuously remains low, because the compressor may be burnt because of oil shortage.

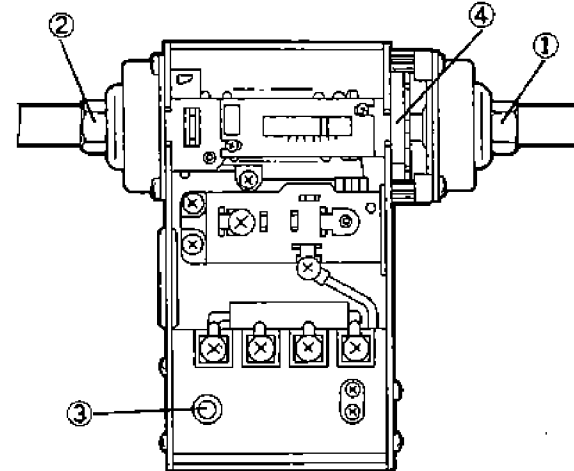

- ① LP ③ Reset button
- ② OP ④ Adjusting gear for setting

① Operation

The oil pressure (pressure difference) normally rises when the compressor has started. If the pressure does not rise, power will be supplied to the heater of a timer and a bimetal operate after a preset interval, thereby stopping the compressor will stop.

Note: Timing device is affected by ambient temperature and its set period differs with ambient temperature. (Standard temperature 25°C (77°F))

| Ambient temperature | Set period |
|---------------------|------------|
| Higher | Shorter |
| Lower | Longer |

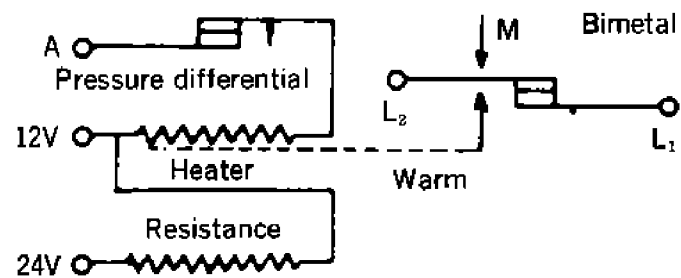

Electric wiring in oil pressure protection switch



② Resetting

If 63QL has operated, cypress the reset button several minutes after when the compressor stops. (The button will not be reset unless the bimetal is cold.)

③ Adjustment method

Adjust the oil pressure protection switch by turning the adjusting gear as described below.

Adjusting points for oil pressure protection switch

- When rotate the adjusting screw clockwise, functional pressure (differential) becomes low and heater circuit is disconnected with low pressure difference. 
- When rotate the adjusting screw counterclockwise, functional pressure (differential) becomes high and heater circuit is disconnected with high pressure difference. 

Note: The following turning directions are viewed from the low pressure connection side.

5.3.6 Recorder (SKM-2924A)

① Specifications

- Model SKM-2924A
- Feeler tube Gas sealed
- Recording method Pressure sensing type
- Recording temperature range $-25 \sim +25^{\circ}\text{C} (-13 \sim +77^{\circ}\text{F})$
- Recording paper Dia. 203 Disk type pressure sensible paper (Graduation $1/1^{\circ}\text{C}$) (Corresponding to PSD-217C (REV. A) made by PARTLOW Co.)
- Driving method for recording paper Timer (Quartz motor + reducing gears) a turn/31 days
Quartz motor driving source: Goods corresponding to Dry battery (DC 1.5V)
JIS C 8501.....SUM2
IECR14
Life is approx. 1 year (Remaining voltage indicator)

② Inspection of recorded temperature

Operate the unit in chilling mode at 0°C (32°F) setting and confirm with the thermometer that the return air temperature has stabilized at 0°C (32°F). Then calibrate the recording pen according to the return air temperature at stop of compressor on the thermometer.

③ Adjustments

- 1) Make adjustments subsequent to the inspection in item.
- 2) Turn the temperature setting screw (A) to adjust the temperature. Loosen the lock screw (B) and turn the setting screw (A) clockwise to temporarily raise the temperature setting by approximately 5°C (9°F). Then turn the setting screw (A) counterclockwise to lower the temperature setting of the pen until the temperature is adjusted to the digital temperature. Tighten the lock screw (B) after the adjustment.

Note:

- 1 One turn of the setting screw (A) changes the temperature setting by approx. 5°C (9°F).
- 2 Be careful that the temperature setting may be altered by tightening the lock screw (B).

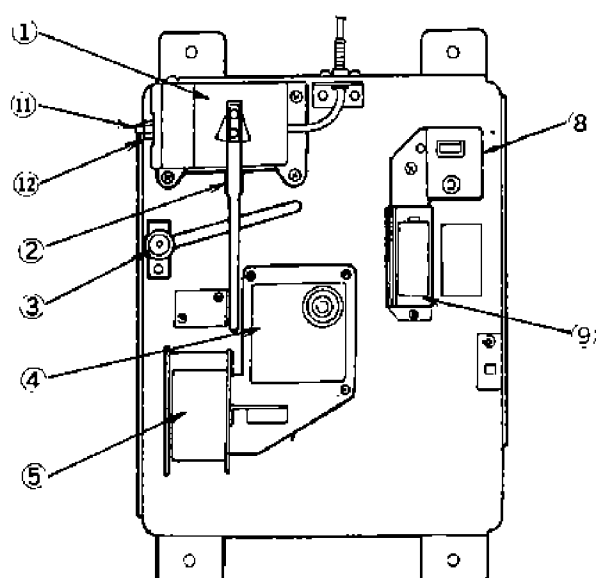
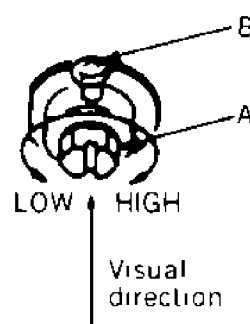
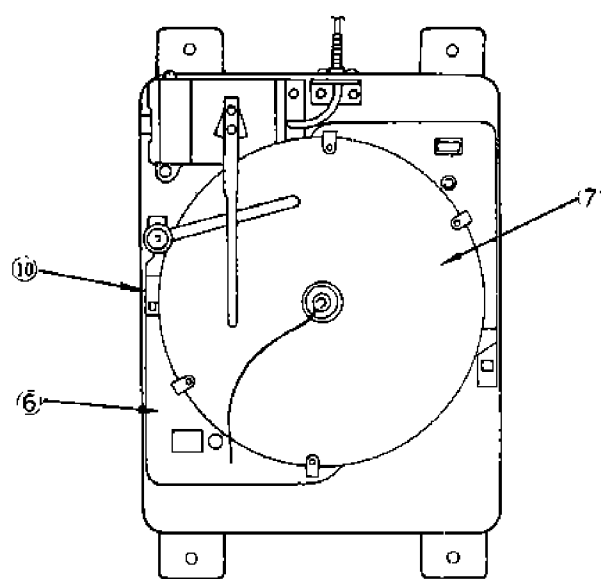

- | | |
|-------------------|-------------------------|
| ① Element | ⑦ Recording paper |
| ② Pen | ⑧ Remaining V indicator |
| ③ Pen lifting arm | ⑨ Battery |
| ④ Reducer | ⑩ Present time plate |
| ⑤ Quartz motor | ⑪ Adjusting screw |
| ⑥ Recording board | ⑫ Lock screw |

- 3) Generally a temperature recorder should be adjusted at 0°C (32°F), but the following method is available when the setting temperature is known.

- Chilled mode (Setting temperature : above -4.5°C [$+23.9^{\circ}\text{F}$])..... "Adjust at 0°C (32°F)."
- Frozen mode (Setting temperature : below -6.5°C [$+20.3^{\circ}\text{F}$])..... "Adjust at -18°C (-0.4°F)."

- 4) Inspection and adjusting method

- adjust a temperature recorder when the container inside temperature becomes decreasing. Temperature recorder's pen shows the temperature correctly when it is decreasing. Don't adjust it when the temperature becomes increasing.

It is caused from its hysteresis that a pen sometimes shows the temperature lower from 1°C (1.8°F) to 3°C (5.4°F) when the temperature is increasing.

- It is a normal phenomena that the recording curves are a little influenced by the fluctuations of the ambient temperature. (Note : Basically the temperature recorder is designed for 25°C (77°F) ambient, and 10°C (18°F) fluctuations of the ambient temperature cause the error of $\pm 0.2^{\circ}\text{C}$. [$\pm 0.4^{\circ}\text{F}$])

- A temperature recorder adjusted at 0°C (32°F) sometimes shows the following curves at -18°C (-0.4°F) inside. It is a normal and allowable range.
If the range exceeds the above, readjust it at 0°C (32°F) (or -18°C [-0.4°F]).
- Don't move the pen by hand, because it will cause an increase of error.
- When the pen is holded by the pen lifter the pen may move unsmoothly, but it is no problem.

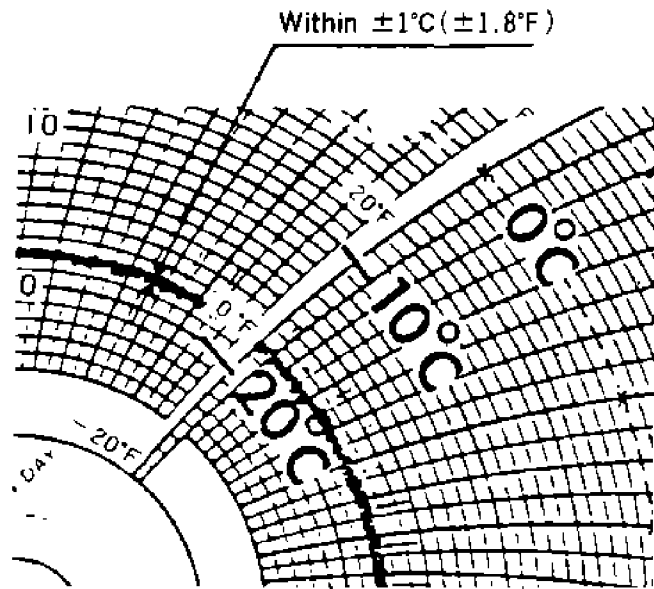

④ Replacement of parts

a. Battery

1) Replacement interval

- When the indicator is out side the blue zone after checking the residual voltage of the battery. (When the indicator is above the dotted lines, i.e., within the white zone shown in the right figure, the battery has approximately one-month life.)

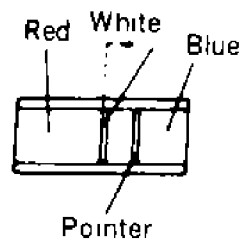

Residual voltage indicator

2) Replacement method

- Remove the recording panel and insert the new battery making certain that the battery polarity is correct. Use SUM-2 of JIS C8501 or IEC R14 battery or the equivalent (DC1.5V dry cell).
- After replacement, confirm that the pointer of the residual voltage indicator is within the blue zone and that the quartz motor functions properly.

b. Residual voltage indicator battery

1) Replacement interval

- In case oscillation of the needle is unstable when the push switch is pressed down for confirmation of remaining voltage.
- In case the remaining voltage indicator needle is within the white zone or in the red zone, although a new battery is set in.

2) Replacement method

- Remove the recording panel by loosening the screw.
Remove the residual voltage indicator battery from the body, and replace it with a new one.
- When replacing the battery make certain that the terminal wirings are connected red to red and black to black
- After replacement confirm that the pointer is within the blue zone and that the quartz motor functions properly.
- Battery is to be replaced every 12 months.

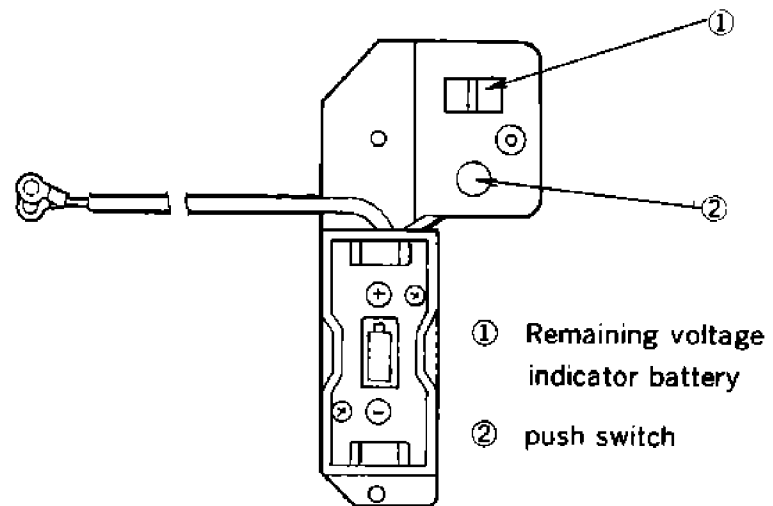

(DKM-AA003)

Residual voltage indicator battery

C. Timer (quartz motor speed reducing gear)

1) Replacement interval

- When the quartz motor does not function even though residual voltage battery is normal.
- When the timer delays over three hours a day.

2) Replacement method

- Remove the recording panel to remove the wiring. Loosen the screws (5 pcs) to remove the timer, and replace the timer with a new one.
- When replacing the timer, also replace the antivibration rubbers (5 pcs). The red wire is for (+) and the black wire for (-), therefore, connect the red terminal with red and the black with black. Tighten the anti-vibration rubbers with torque of 4 ~5kg-cm.
- Confirm that the quartz motor functions correctly after replacement.

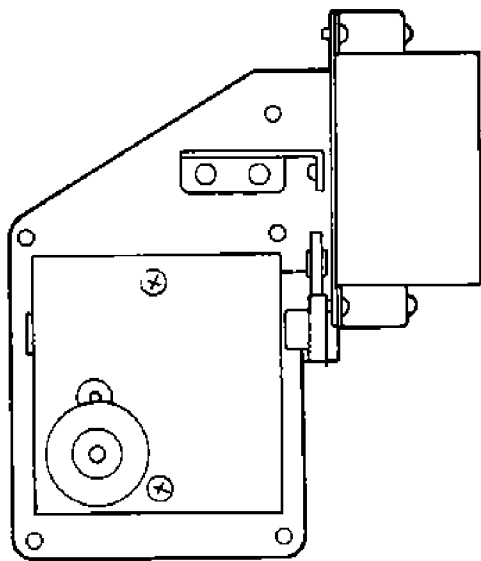

Timer (quartz motor speed reducer)

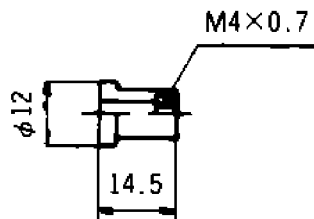

Accessory (anti-vibration rubber : 5 pcs)

d. Thermal feeler tube

1) Replacement interval

- After the pen has been adjusted and the controller has been operated within the temperature range of -18 to +10°C (-0.4 to +50°F), with the inside temperature stabilized at the temperature setting: When the temperature indication under the above conditions deviates by more than 2°C (4°F) against the temperature setting. (When the temperature indication is substantially less than the temperature of the thermal feeler tube, gas leakage may be suspected.)

2) Replacement method

- Loosen the screw and remove the thermal feeler tube-element. Replace it with a new one.
- After replacement, inspect and adjust.

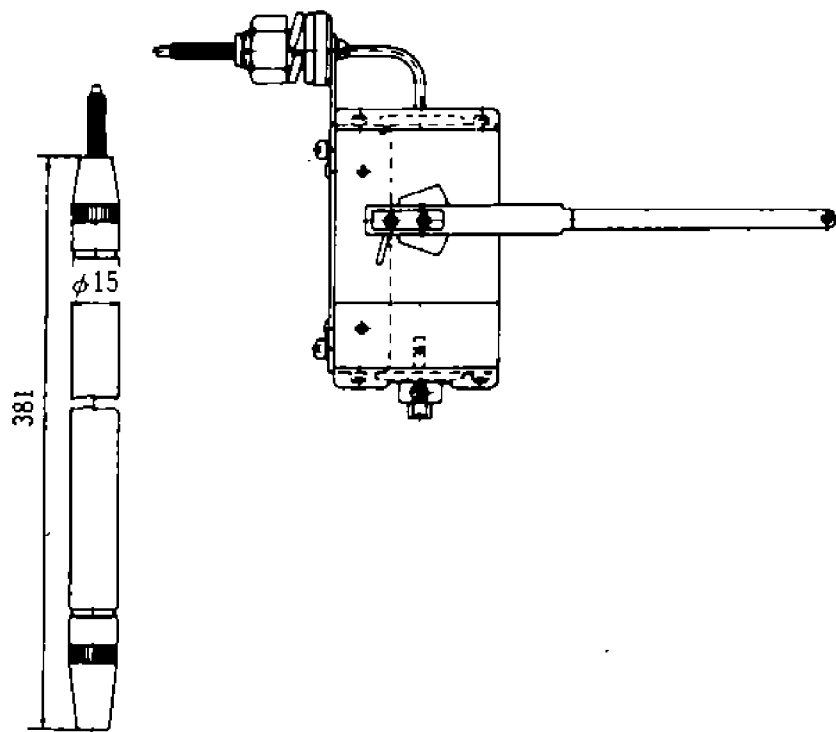

Feeler tube—element ... SKM-AA001

5.3.7 Defrost termination thermistor (26D)

The thermistor indicates termination of defrosting, sensing temperature of the suction piping.

| | |
|-----|-------------|
| OFF | 35°C (95°F) |
| ON | 20°C (68°F) |

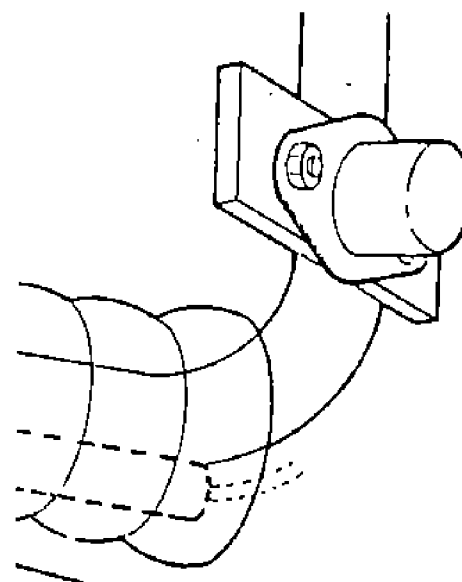

5.3.8 Phase sequence controller (47)

① **Specifications**

- Type: PR8601
- Power supply: 190~200V 50Hz
200~220V 60Hz

The phase sequence controller opens or closes the magnetic contactor for changing-over of phases, detecting phases, R. S. T. in the power supply to prevent the fan motor from reverse turning.

The integrated microcomputer detects voltage of each phase and phase order and operates as tabulated below.

| State of power supply | | Relay RY1 | Relay RY2 | Between terminals 1-2 | Between terminals 1-3 |
|-----------------------|---------------------------------------|--|-----------|-----------------------|-----------------------|
| De-energized period | | OFF | OFF | No continuity | No continuity |
| Energized period | Proper phase | ON | OFF | Continuity | No continuity |
| | Wrong phase | OFF | ON | No continuity | Continuity |
| | Single phasing before supplying power | OFF | OFF | No continuity | No continuity |
| | Single phasing during energization | State before single phasing is retained. | | | |

Note: Single phasing can be judged only on the power supplying side, but not on the load side.

② **Checking method for operation**

Exchange the power sources and check that the microcomputer operates as tabulated above. If not, replace the phase sequence controller.

③ **Cautions for replacing the switch**

Correctly connect each terminal in accordance with the wiring diagram. If not the switch may be burnt, or the microcomputer becomes erratic.

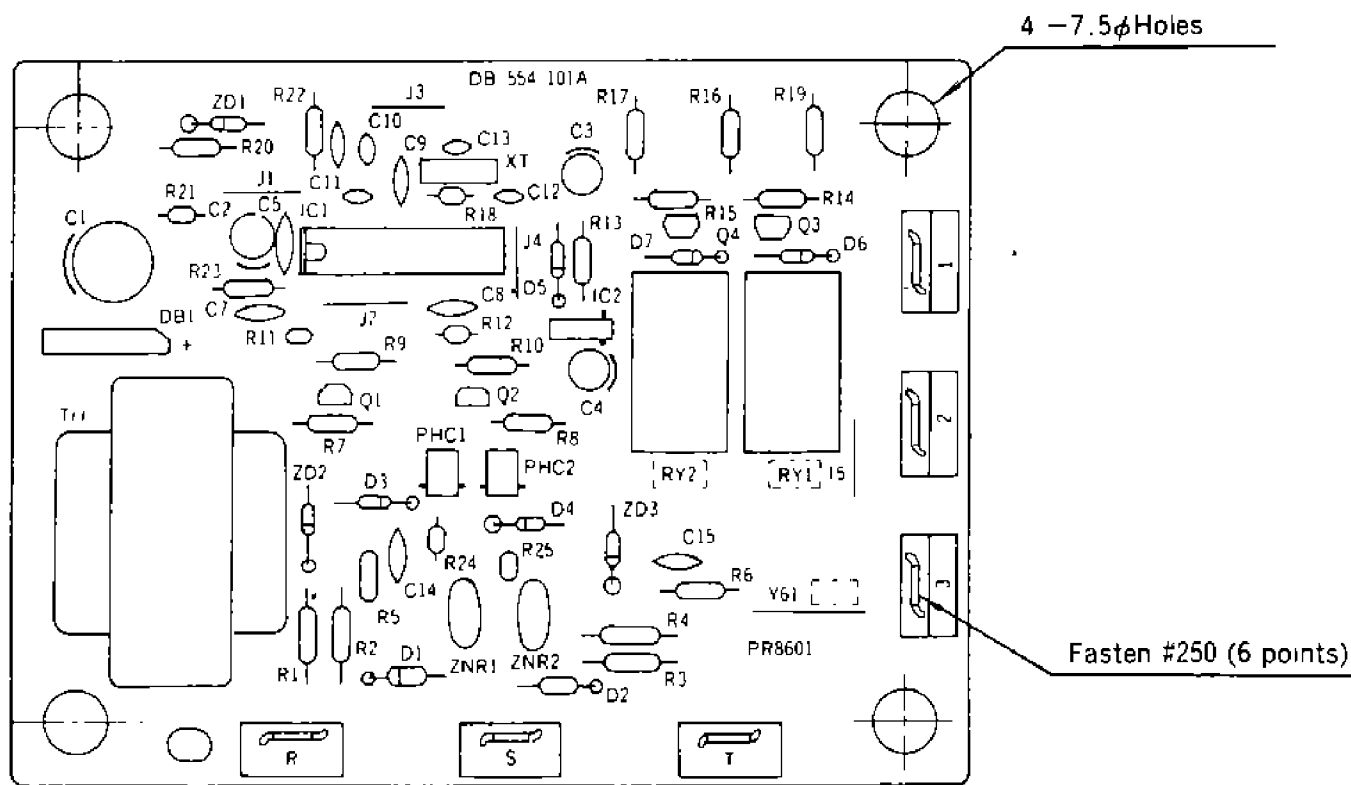

5.3.9 Electronic controller (23A1)

① **Specifications**

- Model: P-CONTR
- Power supply: AC24V 50/60Hz
- Temperature control range: $-25^{\circ}\text{C} \sim +25^{\circ}\text{C}$
- Sensor: Thermistor
- Numbers of output: 5 ea (US, CS, HS, IRS, MS)
- Operation characteristics of switches (In case setting is 0°C)

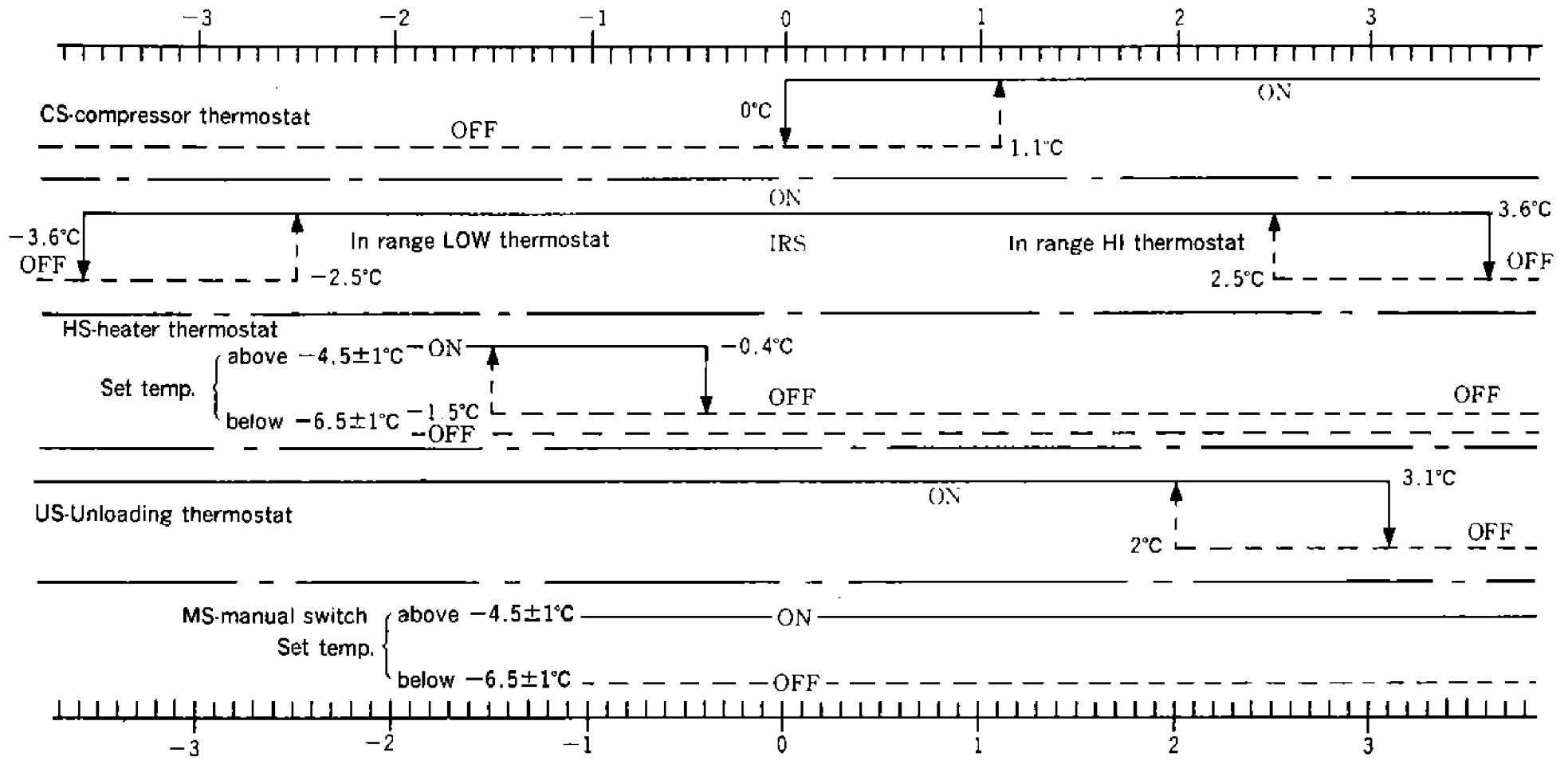

● **External wiring**

- Insulation resistance: DC500V megger $50\text{M}\Omega$ or more
Note: Do not impress the input terminals from 1 to 8
- Dielectric pressure: AC500V for one minute
Note: Do not impress the input terminals from 1 to 8.

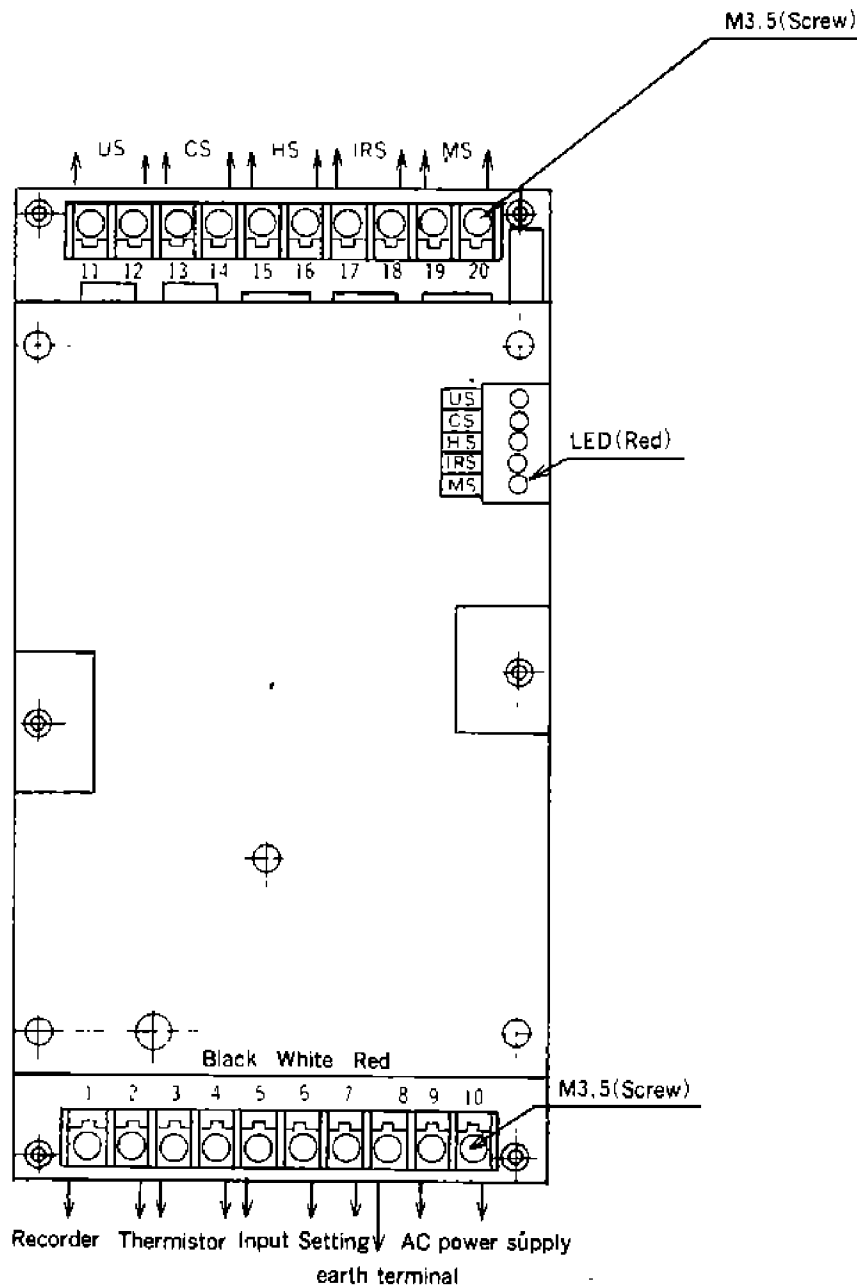

② Check points

a. Check points of thermistor

- 1) Operate the unit, setting the thermostat knob to 0°C.
- 2) When inside temperature becomes even after repeating ON/OFF operation two or three times by the CS compressor thermostat, start checking the thermistor.
- 3) Remove the thermistor from the terminals, 03 and 04 and measure its resistance with a digital voltmeter, and at the same time measure inside temperature with a thermistor thermometer. Then, check that error is within $0 \pm 1.0^\circ\text{C}$, using the attached table for thermistor resistance.
In addition, prepare water, in which ice cubes are put and put a mercury thermometer and thermistor in it and check that error is with $0 \pm 1.0^\circ\text{C}$ by use of the table for thermistor resistance.
- 4) If such error differs largely with that in the table, replace the thermistor, as it must be faulty.

b. Check points of printed circuit board

- 1) Connect the dial resistor to the thermistor terminals, 03 and 04 and check the printed circuit board.
- 2) Set the setter to 0°C.
- 3) Raise temperature of the dial resistor gradually from -50°C ($77.5810\text{k}\Omega$) to 70°C and then make it drop down to -50°C again. (Refer to table for thermistor resistance.)
- 4) Temperature of the dial resistor falls to -50°C again, next time raise it to 2°C . And then make it drop to -50°C again.
- 5) Check that functioning points of the thermostat accord with the points shown in the following diagrams during operation.

※ When the dial resistor is changed from -50°C to $+70^\circ\text{C}$

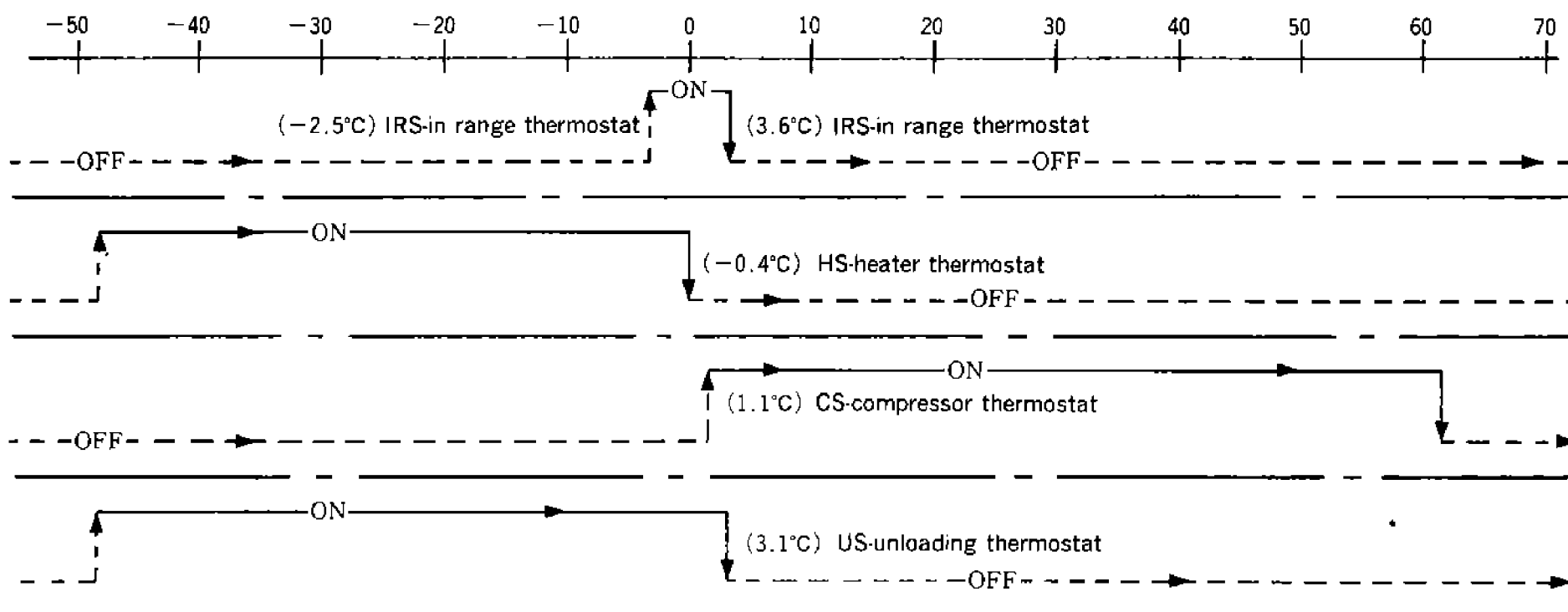

※ When the dial resistor is changed from $+70^\circ\text{C}$ to -50°C

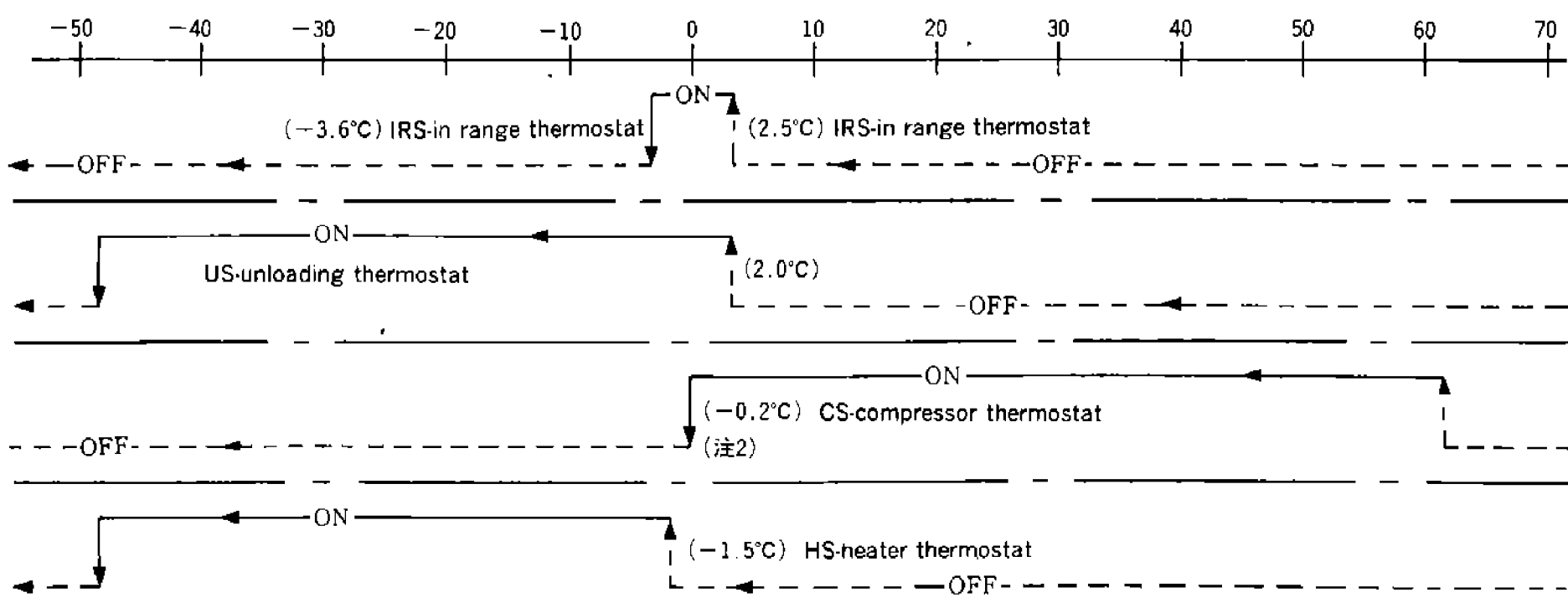

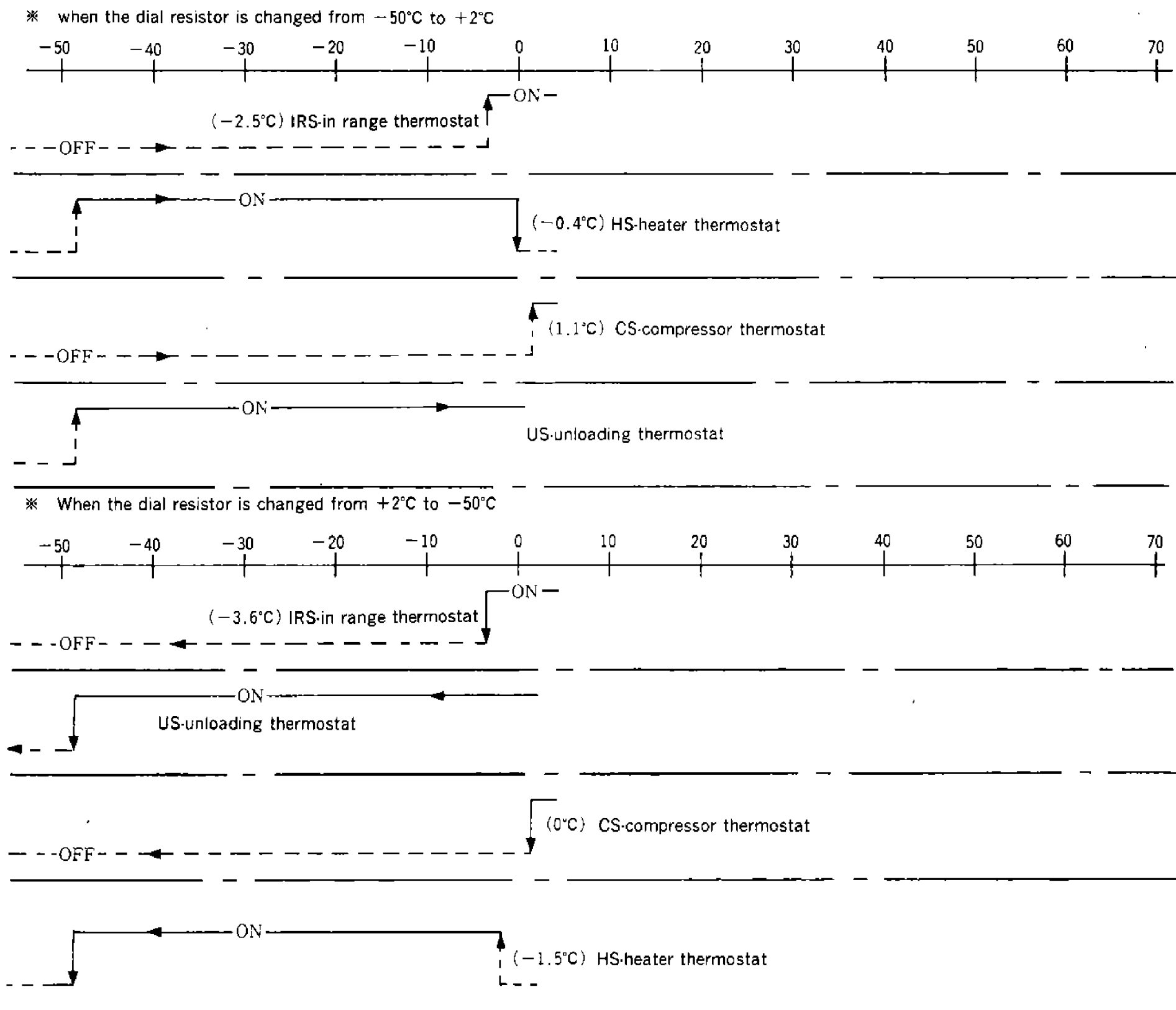

Notes:

1. Move the dial resistor slowly at the functioning point, and do not return it.
 2. In case inside temperature is higher than the in range, functioning point of the CS-thermostat is from -0.2 to $+1.1^{\circ}\text{C}$. If inside temperature is within the in range and the CS thermostat is turned off, functioning point of CS is from 0 to $+1.1^{\circ}\text{C}$.
 3. Confirm the output functions with indication lamp (LED) on controller.
 4. When controller function is checked by set point selector simply during unit operation, check the function of controller after several cycling operation of compressor and getting uniform inside temperature.
- After finishing the checks stated above, check MS (manual switch). Set the thermistor input to -10°C with the dial resistor. After that, turn the setting knob. When setting is lowered : From ON to OFF at $-6.5^{\circ}\text{C} \pm 1.0^{\circ}\text{C}$
When setting is raised : From OFF to ON at $-4.5^{\circ}\text{C} \pm 1.0^{\circ}\text{C}$
 - After checking, if accuracy of the printed circuit board is insufficient, replace it.

5.3.10 Electronic controller (23A2)

① Specifications

- Model : P-TIMER
- Power supply : AC24V 50/60Hz
- Sensor : Thermistor
- Thermostat output

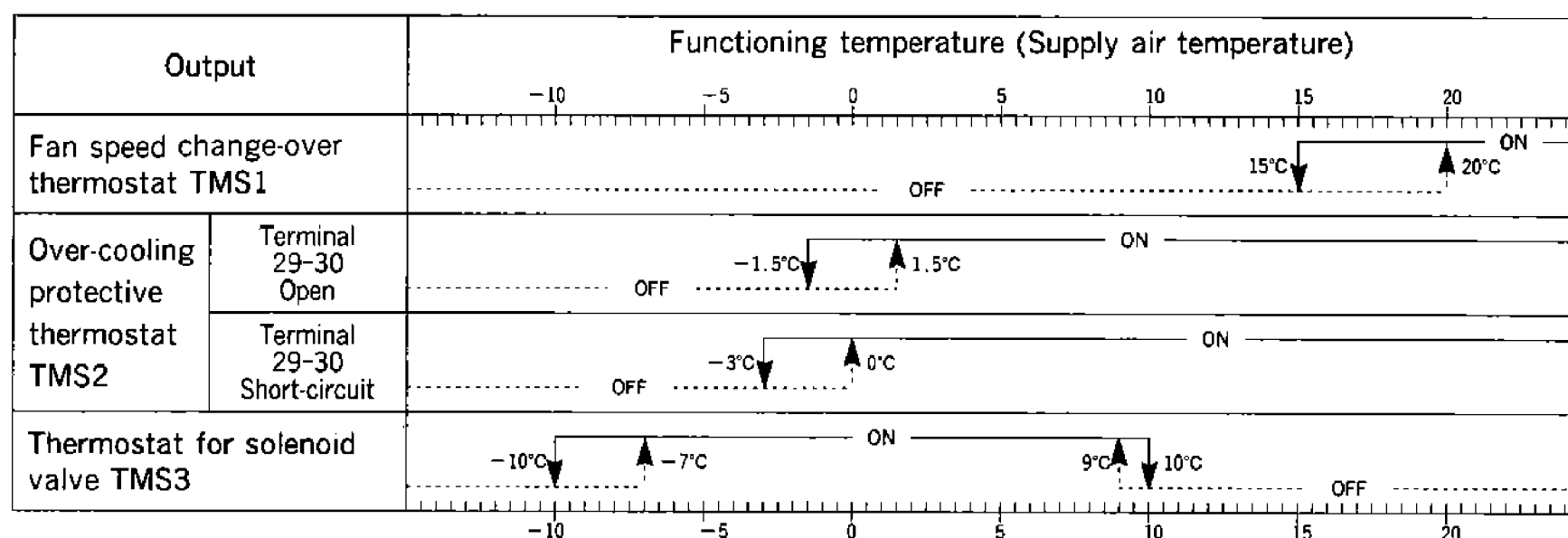

● Timer output

| Output | | Setting timer |
|--------------------------------------|--------------------|---------------|
| Fan delay timer 2F1 | | 60 seconds |
| Fan delay timer 2F2 | | 10 seconds |
| Defrost initiation timer (Short) 2D1 | Factory setting | 4 hours |
| | Switch change-over | 3 hours |
| Defrost initiation timer (Long) 2D2 | Factory setting | 12 hours |
| | Switch change-over | 24 hours |
| Defrost delay timer 2D3 | | 20 seconds |
| Defrost back-up timer 2D4 | | 90 minutes |

- Insulation resistance: DC500Vmegger 50MΩ or more
Note: Do not impress the input terminals 32~33
- Dielectric pressure: AC500V for one minute
Note: Do not impress the input terminals 32~33

② Checking method for operation

a. Checking thermostats for their outputs

- Set the set point selector to 0°C, and make pull-down start at supply air temperature above +25°C. Compare output functioning point of each thermostat with supply air temperature to check the difference between them is within ±2°C. Note that the thermistor does not follow speed of pull-down if it is very quick.
In order to check the functioning point on the low temperature side of the solenoid valve thermostat (TMS3) at -10/-7°C, set the unit to -18°C.
 - When dial resistance is used for the check, refer to the conversion table for "Resistance VS. Temperature".
- 1) Connect the dial resistor to the thermistor terminals, 32 and 33 and check the printed circuit board.
 - 2) Raise temperature of the dial resistor gradually from -50°C (77.5810kΩ) to 70°C and then make it drop down to -50°C again. (Refe to table for thermistor resistance.)
 - 3) Check that functioning points of the thermostat accord with the points are thermostat temperature setting.

b. Checking timers for their outputs

● 2D1, 2D2, 2D4

Check the defrost initiation timers, 2D1, 2D2 and 2D4 by use of the timer test pin.

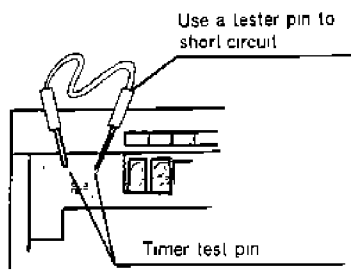

When the timer test pin is short-circuit, the following timer countings are shortened.

2D1 4 hours → 4 seconds

2D2 12 hours → 12 seconds

2D4 90 minutes → 9 seconds

- Set the set point selector to the temperature at which the unit starts and the lamp for IN RANGE goes off. When the timer pin is short-circuit, timer counting is shortened and defrosting starts. Defrosting will start by 2D1 4 seconds later after turning on the test switch, and the pilot lamps for DEFROST and IN RANGE will light up. So measure such a time lag. After initiation of defrosting, the lamp for IN RANGE will go off 9 seconds later by 2D4, so measure such a time lag.
- Regarding 2D2, operate the unit in the same manner and set the set point selector to the temperature at which the lamp for IN RANGE lights up. The lamp for DEFROST will light up 12 seconds later by 2D2 after short-circuit.
- 2D3
Operate the unit and turn on the manual defrost switch to start defrosting, and pump-down operation will start soon. When pump-down operation is finished, the compressor will stop for 20 seconds by 2D3 and then will restart.
- 2F1
When the operation switch is turned on at inside temperature above 25°C the fan is delayed in starting by 10 seconds by 2F1, and then will run in low speed.
- 2F2
After finishing defrosting (after the lamp for DEFROST going off), the fan is delayed in starting by one minute by 2F2, and will run.

c. Check points of thermistor

Remove the thermistor from the terminals, 32 and 33, and measure its resistance with a digital voltmeter, and at the same time measure inside temperature with a thermistor thermometer. Then, check that error is within $\pm 1.0^{\circ}\text{C}$ using the attached table for thermistor resistance.

In addition, prepare water, in which ice cubes are put and put a mercury thermometer and thermistor in it and check that error is within $\pm 1.0^{\circ}\text{C}$ by use of the table for thermistor resistance.

If such error differs largely with that in the table, replace the thermistor, as it must be faulty.

③ **Timer change-over switch**

The defrost initiation timers, 2D1 and 2D2 can be changed in timer settings by the timer changer-over switch.

Use a small screwdriver to change timer settings.

| | Factory setting | Switch change-over |
|-----|-----------------|--------------------|
| 2D1 | 4H(hr) | 3H(hr) |
| 2D2 | 12H(hr) | 24H(hr) |

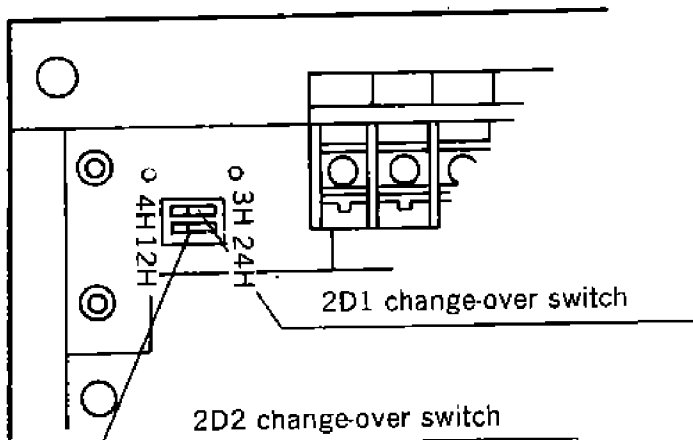

④ **External wiring**

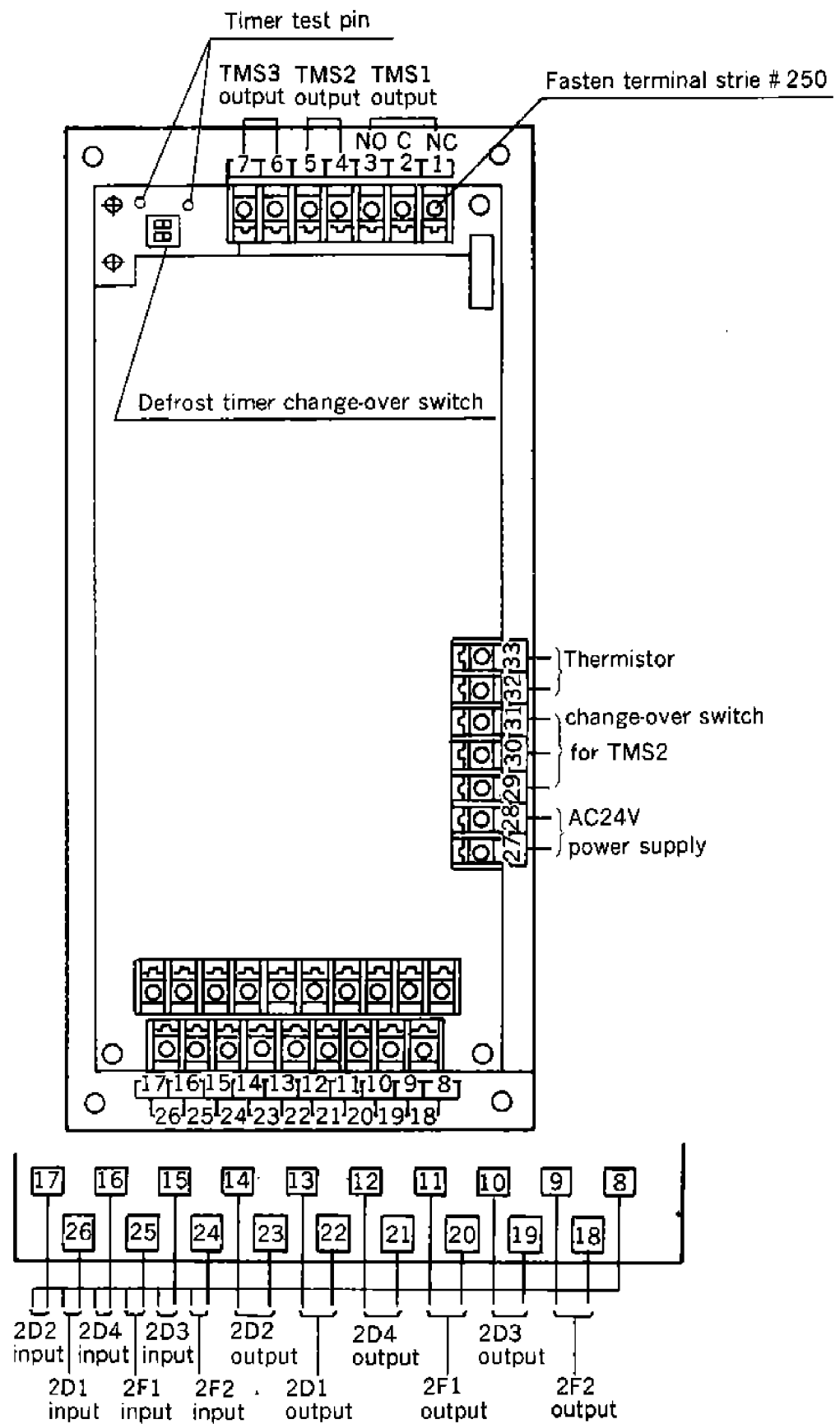

⑤ Sensor characteristics

(Resistance-temperature conversion table)

| Temperature °C | Resistance KΩ | Temperature °C | Resistance KΩ | Temperature °C | Resistance KΩ | Temperature °C | Resistance KΩ | Temperature °C | Resistance KΩ |
|----------------|---------------|----------------|---------------|----------------|---------------|----------------|---------------|----------------|---------------|
| -50.0 | 77.5810 | -27.5 | 22.0854 | -5.0 | 7.4810 | 17.5 | 2.9140 | 40.0 | 1.2740 |
| -49.5 | 75.2718 | -27.0 | 21.5230 | -4.5 | 7.3151 | 18.0 | 2.8575 | 40.5 | 1.2522 |
| -49.0 | 73.0412 | -26.5 | 20.9770 | -4.0 | 7.1534 | 18.5 | 2.8023 | 41.0 | 1.2309 |
| -48.5 | 70.8862 | -26.0 | 20.4471 | -3.5 | 6.9959 | 19.0 | 2.7483 | 41.5 | 1.2100 |
| -48.0 | 68.8039 | -25.5 | 19.9326 | -3.0 | 6.8422 | 19.5 | 2.6956 | 42.0 | 1.1896 |
| -47.5 | 66.7917 | -25.0 | 19.4330 | -2.5 | 6.6929 | 20.0 | 2.6440 | 42.5 | 1.1695 |
| -47.0 | 64.8468 | -24.5 | 18.9443 | -2.0 | 6.5471 | 20.5 | 2.5934 | 43.0 | 1.1498 |
| -46.5 | 62.9667 | -24.0 | 18.4698 | -1.5 | 6.4051 | 21.0 | 2.5440 | 43.5 | 1.1306 |
| -46.0 | 61.1491 | -23.5 | 18.0090 | -1.0 | 6.2666 | 21.5 | 2.4957 | 44.0 | 1.1117 |
| -45.5 | 59.3916 | -23.0 | 17.5615 | -0.5 | 6.1316 | 22.0 | 2.4484 | 44.5 | 1.0932 |
| -45.0 | 57.6920 | -22.5 | 17.1268 | 0 | 6.0000 | 22.5 | 2.4022 | 45.0 | 1.0750 |
| -44.5 | 56.0336 | -22.0 | 16.7045 | 0.5 | 5.8709 | 23.0 | 2.3570 | 45.5 | 1.0571 |
| -44.0 | 54.4298 | -21.5 | 16.2943 | 1.0 | 5.7450 | 23.5 | 2.3128 | 46.0 | 1.0396 |
| -43.5 | 52.8785 | -21.0 | 15.8957 | 1.5 | 5.6223 | 24.0 | 2.2696 | 46.5 | 1.0224 |
| -43.0 | 51.3779 | -20.5 | 15.5084 | 2.0 | 5.5026 | 24.5 | 2.2273 | 47.0 | 1.0055 |
| -42.5 | 49.9262 | -20.0 | 15.1320 | 2.5 | 5.3859 | 25.0 | 2.1860 | 47.5 | 0.9890 |
| -42.0 | 48.5215 | -19.5 | 14.7634 | 3.0 | 5.2720 | 25.5 | 2.1454 | 48.0 | 0.9728 |
| -41.5 | 47.1621 | -19.0 | 14.4052 | 3.5 | 5.1610 | 26.0 | 2.1056 | 48.5 | 0.9569 |
| -41.0 | 45.8465 | -18.5 | 14.0571 | 4.0 | 5.0527 | 26.5 | 2.0667 | 49.0 | 0.9413 |
| -40.5 | 44.5729 | -18.0 | 13.7186 | 4.5 | 4.9471 | 27.0 | 2.0287 | 49.5 | 0.9260 |
| -40.0 | 43.3400 | -17.5 | 13.3896 | 5.0 | 4.8440 | 27.5 | 1.9915 | 50.0 | 0.9110 |
| -39.5 | 42.1361 | -17.0 | 13.0698 | 5.5 | 4.7428 | 28.0 | 1.9550 | 50.5 | 0.8962 |
| -39.0 | 40.9705 | -16.5 | 12.7587 | 6.0 | 4.6440 | 28.5 | 1.9194 | 51.0 | 0.8817 |
| -38.5 | 39.8420 | -16.0 | 12.4563 | 6.5 | 4.5477 | 29.0 | 1.8845 | 51.5 | 0.8674 |
| -38.0 | 38.7491 | -15.5 | 12.1621 | 7.0 | 4.4536 | 29.5 | 1.8504 | 52.0 | 0.8534 |
| -37.5 | 37.6907 | -15.0 | 11.8760 | 7.5 | 4.3619 | 30.0 | 1.8170 | 52.5 | 0.8397 |
| -37.0 | 36.6654 | -14.5 | 11.5958 | 8.0 | 4.2723 | 30.5 | 1.7842 | 53.0 | 0.8263 |
| -36.5 | 35.6722 | -14.0 | 11.3233 | 8.5 | 4.1849 | 31.0 | 1.7520 | 53.5 | 0.8131 |
| -36.0 | 34.7100 | -13.5 | 11.0582 | 9.0 | 4.0996 | 31.5 | 1.7205 | 54.0 | 0.8002 |
| -35.5 | 33.7776 | -13.0 | 10.8003 | 9.5 | 4.0163 | 32.0 | 1.6897 | 54.5 | 0.7875 |
| -35.0 | 32.8740 | -12.5 | 10.5493 | 10.0 | 3.9350 | 32.5 | 1.6596 | 55.0 | 0.7750 |
| -34.5 | 31.9911 | -12.0 | 10.3051 | 10.5 | 3.8553 | 33.0 | 1.6300 | 55.5 | 0.7627 |
| -34.0 | 31.1355 | -11.5 | 10.0675 | 11.0 | 3.7775 | 33.5 | 1.6011 | 56.0 | 0.7507 |
| -33.5 | 30.3063 | -11.0 | 9.8363 | 11.5 | 3.7015 | 34.0 | 1.5728 | 56.5 | 0.7388 |
| -33.0 | 29.5024 | -10.5 | 9.6111 | 12.0 | 3.6273 | 34.5 | 1.5451 | 57.0 | 0.7272 |
| -32.5 | 28.7230 | -10.0 | 9.3920 | 12.5 | 3.5548 | 35.0 | 1.5180 | 57.5 | 0.7158 |
| -32.0 | 27.9674 | -9.5 | 9.1772 | 13.0 | 3.4840 | 35.5 | 1.4913 | 58.0 | 0.7047 |
| -31.5 | 27.2346 | -9.0 | 8.9681 | 13.5 | 3.4149 | 36.0 | 1.4651 | 58.5 | 0.6937 |
| -31.0 | 26.5239 | -8.5 | 8.7645 | 14.0 | 3.3474 | 36.5 | 1.4394 | 59.0 | 0.6829 |
| -30.5 | 25.8347 | -8.0 | 8.5663 | 14.5 | 3.2814 | 37.0 | 1.4143 | 59.5 | 0.6724 |
| -30.0 | 25.1660 | -7.5 | 8.3732 | 15.0 | 3.2170 | 37.5 | 1.3897 | 60.0 | 0.6620 |
| -29.5 | 24.5121 | -7.0 | 8.1853 | 15.5 | 3.1536 | 38.0 | 1.3656 | | |
| -29.0 | 23.8776 | -6.5 | 8.0022 | 16.0 | 3.0916 | 38.5 | 1.3420 | | |
| -28.5 | 23.2621 | -6.0 | 7.8239 | 16.5 | 3.0310 | 39.0 | 1.3189 | | |
| -28.0 | 22.6649 | -5.5 | 7.6502 | 17.0 | 2.9718 | 39.5 | 1.2962 | | |

6. Maintenance

6.1 Handling method of the stop valves

(1) Place of the stop valve and its kind

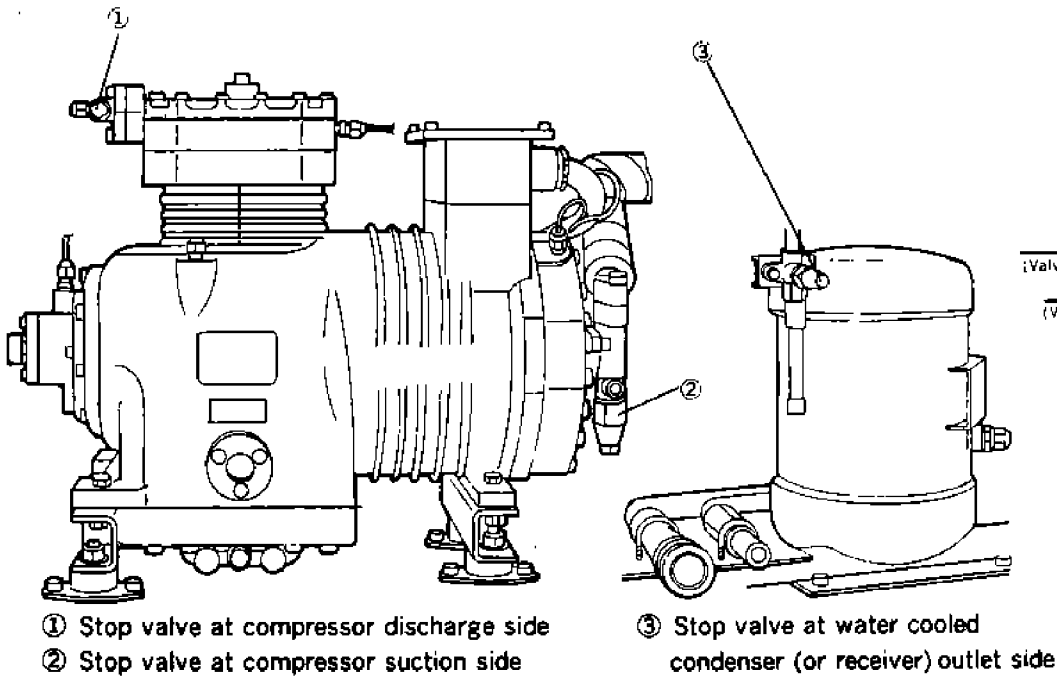

(2) Structure of stop valve

1 Stop valve at compressor discharge side (VSH10VAP-5S)

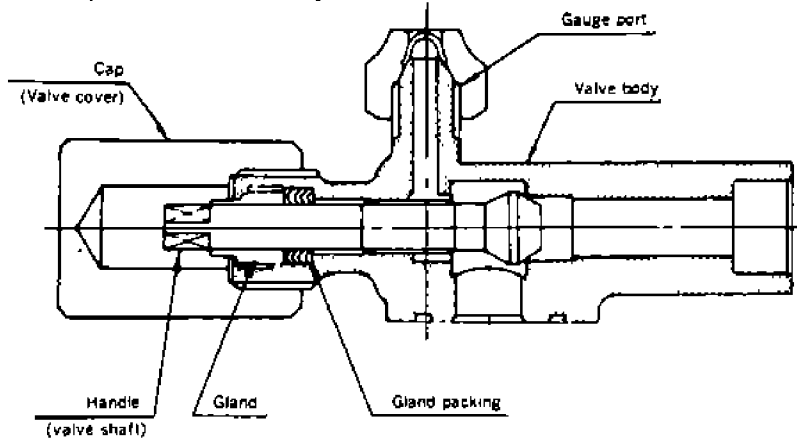

2 Stop valve at compressor suction side (VSH22XBP)

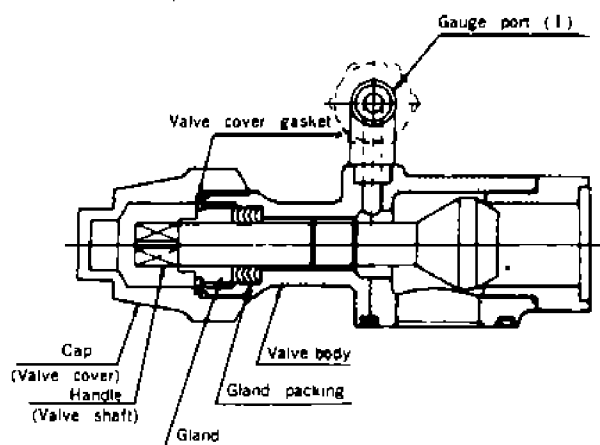

3 Stop valve at water cooled condenser (or receiver) outlet side (VSV10CBP-4S-4SR)

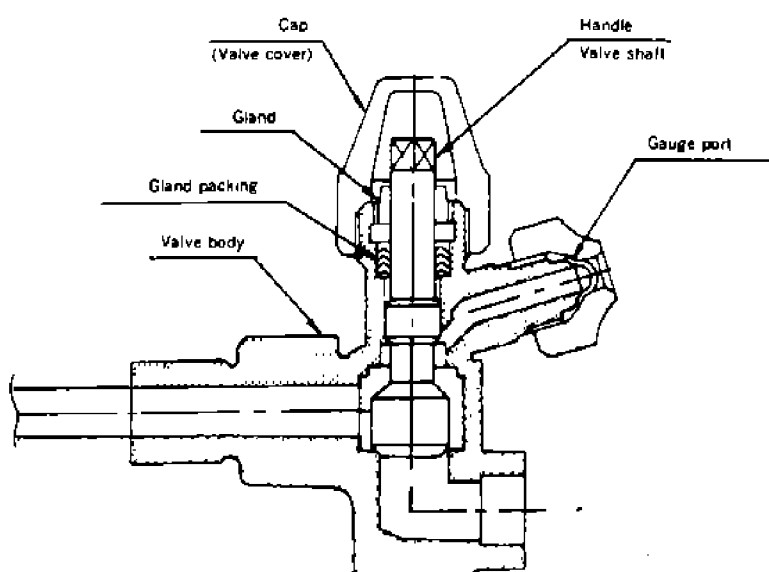

(3) Handling method

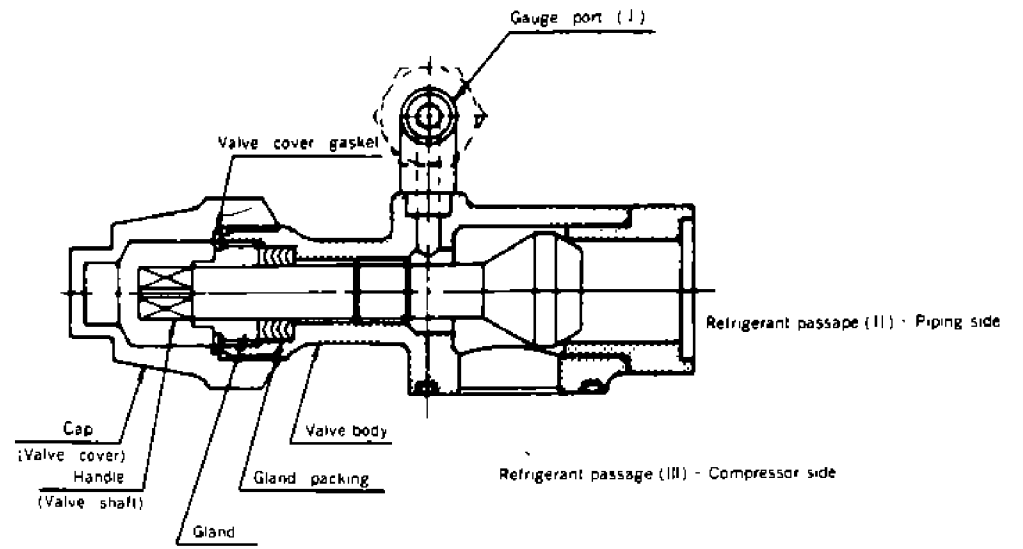

- 1) Remove the valve cap. At this time, be careful not to lose the gasket.
- 2) Loosen the gland in a way the refrigerant is not extracted.
- 3) Fully close the handleThe refrigerant passage I is connected to III (Front seat)
- 4) Fully release the handle.....The refrigerant passage II is connected to III (Back seat)
- 5) Set the handle at the neutral positionThe refrigerant passage I is connected to II and III.
- 6) The refrigerant passage differs with the procedure mentioned in 3, 4, or 5. So select the best passage by necessity.
- 7) Operate the handle, tighten the gland and place the valve cap as it was after completion of the work. At this time, do not forget to attach the gasket.

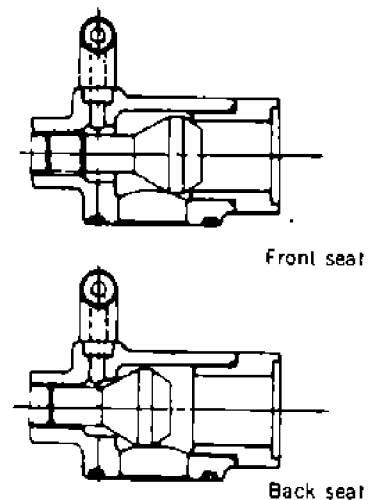
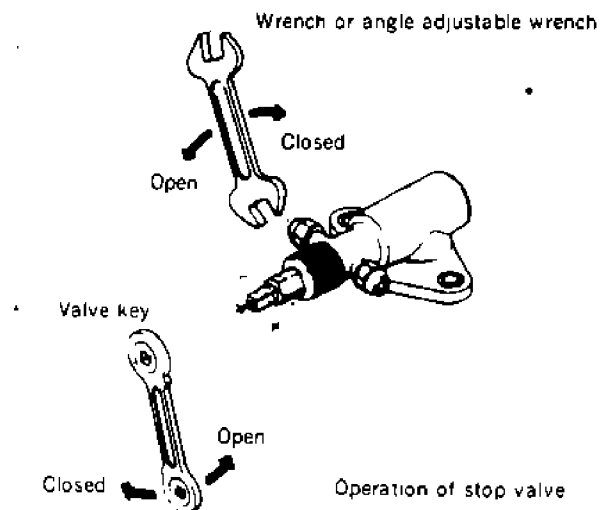

6.2 Attaching or removing points of pressure gauges

(1) Attaching a general pressure gauge

- 1) After opening the compressor suction valve and the water cooled condenser (or receiver) valve fully (back seat), connect a pipe to the gauge port.
- 2) Loosen a little the flare nut on the pressure gauge side and tighten the handle of the stop valve a little (Middle seat) and return it at once. Thus the air is purged.
- 3) After purging the air, accurately tighten up the flare nut on the pressure gauge side.
- 4) Close the handle of the stop valve a little, and confirm that the needle of the gauge rises.
- 5) Be certain that the needle of the pressure gauge does not oscillate during the operation of the unit. If it oscillates, do not close the gauge port fully and open the handle of the stop valve a little.
- 6) In case the pressure gauge is attached to the low pressure side, if the low pressure is lower than the atmospheric pressure, the air is drawn in the piping during the air purging. So install the pressure gauge after confirming that low pressure is higher than the atmospheric pressure.
- 7) Operate the unit and confirm that unit is stopped without pump down.

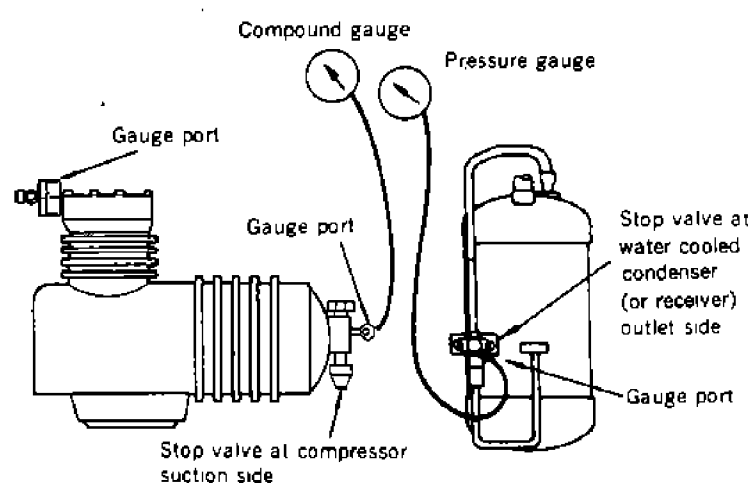

(2) Attaching the gauge manifold

- 1) With regard to mounting points, note the same caution as that for general pressure gauges.
- 2) Open the cocks which are attached to the both sides of the gauge manifold when mounting. Loosen the blind cover of the centre hose, and close the gauge port for the compressor suction valve and the water cooled condenser (or receiver) outlet valve. (Back seat)
- 3) Attach the flare nut of the hose of the manifold on the high pressure side tightly and on the low pressure side loosely.
- 4) Loosen the water cooled condenser (or receiver) outlet valve and vent the air from the hose on the low pressure side and the centre hose and then once again keep the stop valve in the back seat state. After that, tighten up the flare nut on the low pressure side.
- 5) After closing the cocks of the gauge manifold, keep the cock of the compressor suction valve and water cooled condenser (or receiver) outlet valve at the neutral seat and measure pressure.

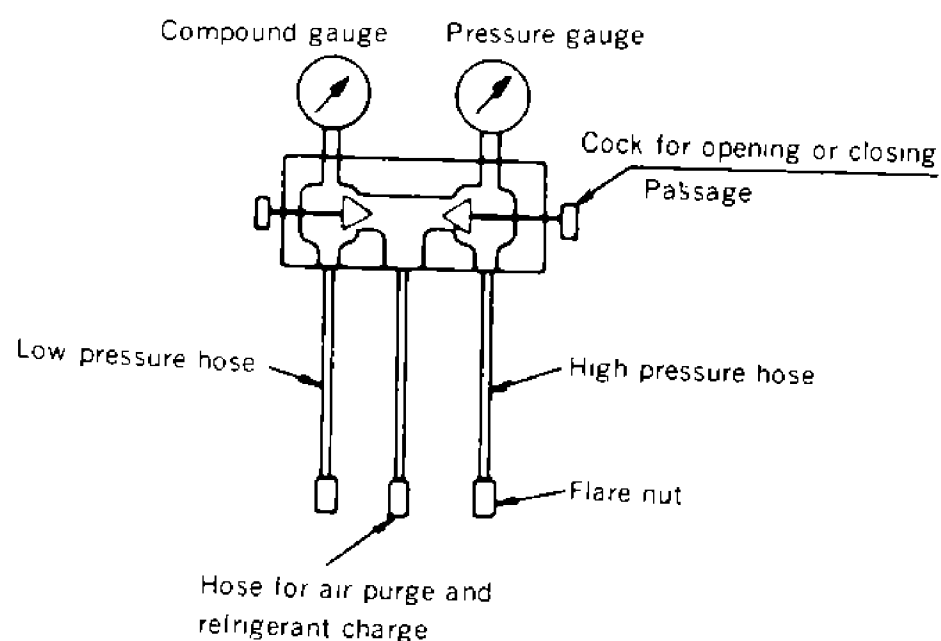

Structure of gauge manifold

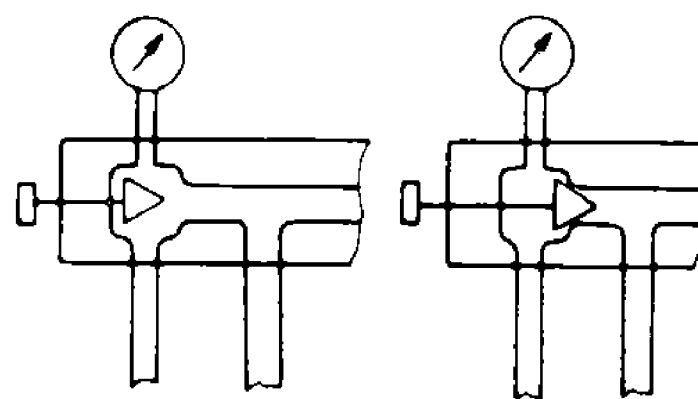

Opening state

Closing state

Opening and closing states of gauge manifold

(3) Removing the pressure gauge and the gauge manifold, as stated below.

When the high pressure hose is removed, note that the liquid refrigerant in the hose may jet out, which is very dangerous.

- 1) Hold the handle of the stop valve in the back seat state, and close the gauge port.
- 2) Open the cock (in case of gauge manifolds) or the flare nuts (in case of general pressure gauges) a little to extract the refrigerant from the hose. At this time, do not open it suddenly so as not to joint out liquid refrigerant.
- 3) After extracting the refrigerant from the hose, remove the pipe connection for the gauge piping.
- 4) Place the blind cover on the gauge port of the stop valve, accurately tighten up the flare nut and confirm no refrigerant leaks.

Note : Since the blind cover is very small, be careful not to lose it.

6.3 Pump down

Pump down means that the refrigerant in the refrigeration circuit is liquidized and collected in the water cooled condenser (or receiver). This work is required to repair the refrigeration circuit for minimizing leaking volume of the refrigerant and risks due to pressure rising.

<Working procedure>

- 1) Install pressure gauges to the high pressure side the low pressure side.
- 2) Operate the refrigeration unit (either on water cooled or air cooled operation)
- 3) Close the water cooled condenser (or receiver) outlet valve.
- 4) Stop the operation when reading of the low pressure gauge becomes 0.1 kg/cm² and close the compressor discharge valve.
- 5) After a short while, read the low pressure gauge. If pressure rises, open the compressor discharge valve and repeat the same procedure.
- 6) Repeat the same procedure two or three times, and the refrigerant is collected in the water cooled condenser (or receiver).

6.4 Charging and purging the refrigerant, refrigeration oil

(1) Purging non-condensable gas

If non-condensable gas such as air exists in the refrigeration circuit, it is collected by the water cooled condenser (or receiver), which raise pressure in the water cooled condenser (or receiver) abnormally high and reduces heat transferring ratio of the condenser surface. If is, therefore, very important to extract non-condensable gas.

If discharge pressure is abnormally high (even though cooling water volume is increased, in case of water cooled operation) and will not return to the normal pressure, inspect if non-condensable gas such as air exists in the following method.

- Stop the compressor, close the water cooled condenser (or receiver) valve and wait until leaving and entering cooling air (or water) of the air (water) cooled condenser become equal. If there is any difference between saturated pressure corresponding to cooling air (water) and condensing pressure, non-condensable gas exists. In this case, purge non-condensable gas as stated below.
- 1) Accomplish pump down .
 - 2) Condense the refrigerant as much as possible, and then discharge it from the gauge port of the compressor discharge valve.
 - 3) Discharge the condensed refrigerant repeatedly reading the pressure gauge until condensing pressure becomes saturated pressure.

(2) Refrigerant purge

There are two methods of refrigerant purge ; i.e. one is for collecting the the refrigerant extracted in a cylinder and the other is for discharging it to the atomosphere.

- (a) Collecting the refrigerant in a cylinder
 - 1) Prepare an empty cylinder which has been dried by forming vacuum inside and weigh it.

- 2) The cylinder is connected to the gauge port of the water cooled condenser (or receiver) by piping with the cylinder cock closed, and then loosen the flare nut on the cylinder side a little to vent the air from the piping.
- 3) Operate the refrigeration unit to pump down the refrigerant.
- 4) After completion of pump down, open the gauge port of the water cooled condenser (or receiver) and then open the cock of the cylinder to collect the liquid refrigerant into the cylinder.
- 5) After collecting the refrigerant, close the gauge port and the cock and then remove the piping.
- 6) Be certain that the refrigerant has been collected in the cylinder by weighing it.
- 7) As for the refrigerant remaining in the refrigeration circuit, extract it to the atmosphere.

(b) Extracting the refrigerant to the atomosphere

- 1) Open the gauge port on the suction side of the compressor to extract the gaseous refrigerant to the atmosphere.
- 2) Do not open the compressor discharge valve or the gauge port of the water cooled condenser (or receiver), otherwise the refrigerant oil and the liquid refrigerant are discharged, which may result in shortage of oil or getting chillblains.
- 3) Do not extract the refrigerant in a closed room and also confirm there is no fire around it. Although the refrigerant is non-toxic, there may be fear of suffocation. In addition, if the refrigerant contacts with fire, it yields phosgene gas (toxic gas).

(3) Vacuum drying and charging refrigerant and refrigeration oil

If all the refrigerant has leaked out and the air is intermixed in the refrigeration circuit, repair a cause of trouble and do vacuum drying. Then charge the predesigned volume of refrigerant. In case the refrigerant oil is replaced, do the same.

(Required tools)

1. Refrigerant cylinder (20 kg) for R12 (CC12F2) with mouth piece
2. Refrigeration oil (20 ℓ can) SUNISO 3GS-DI
3. φ6.4 CuT (with two flare nuts)
4. Pressure gauge (20 kg/cm²), compound gauge (10 kg/cm² × 75 cmHg) } or gauge manifold
5. Weighing scale (Up to 50 kg)
6. Tools
7. Vacuum pump

- (a) In case the refrigerant is replenished without exchanging the refrigeration oil.
- 1) Connect the vacuum pump to the gauge ports of the compressor suction and discharge valves, form vacuum down to 76 cmHg, hold the stop valve in the back seat state and then remove the vacuum pump, leaving the vacuum state in the refrigeration circuit. However, when air enters in the refrigeration circuit, form the vacuum in the circuit down to 76 cmHg and leave it for more than 2 hours (vacuum drying).

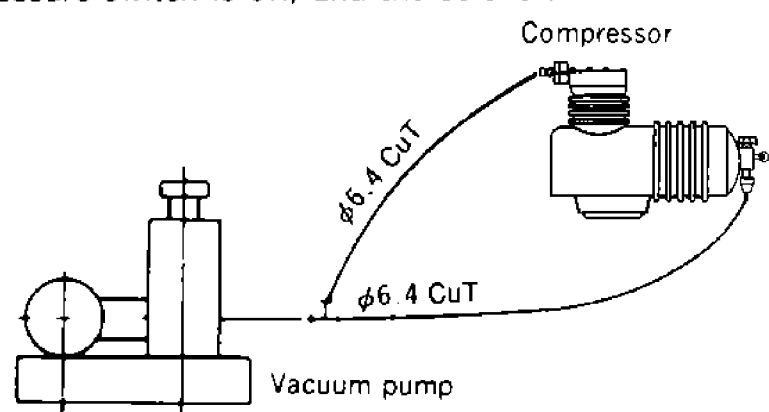

- 3) Place a refrigerant cylinder on the weighting scale, and record its weight.
- 4) In case the refrigerant is charged in the liquid state, do it as shown in the below figure (A). Prevent the liquid refrigerant collected in the water cooled condenser (or receiver) from flowing to the low pressure side. If the refrigerant is hardly charged, operate the compressor to charge it.

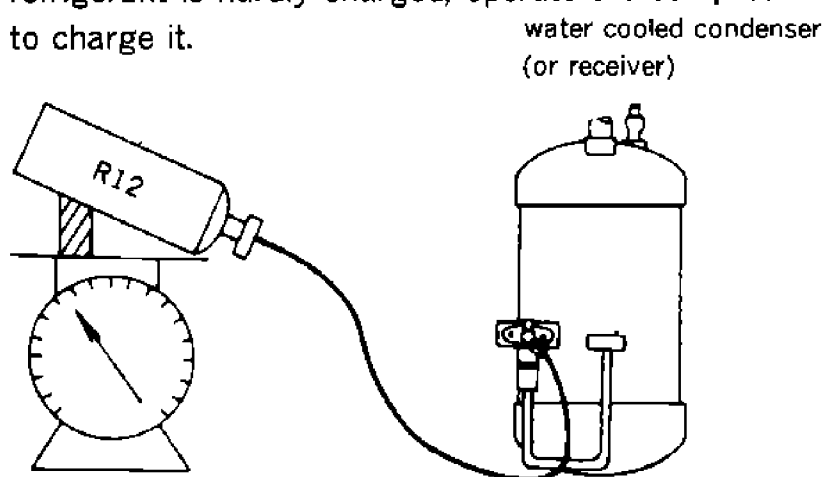

(A) Hold the stop valve in the front seat.

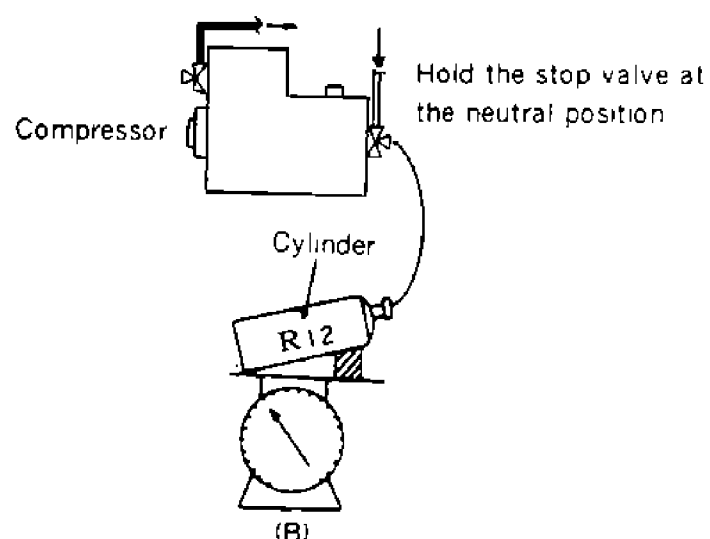

(B)

- 5) In case the refrigerant it charged in the gaseous state, do it as shown in above figure (B). If the refrigerant is hardly charged, operate the compressor to charge it.

- 6) Charge the predesigned volume of the refrigerant in the above stated methods either in 4 or 5.
- 7) After completion of refrigerant charge, hold the stop valve in the back seat state and confirm that if the predesigned volume of the refrigerant has been charged by operating the refrigeration unit.

- (b) Charging the refrigerant as well after replenishment of refrigerant oil

- 1) Extract the refrigerant oil. → Firstly discard all the gas so that pressure in the refrigerant circuit becomes 0. Then loosen the drain plug at the bottom of the compressor to extract all the oil. At this time, firstly open the oil charge plug and then the drain plug to prevent the oil from jetting out.

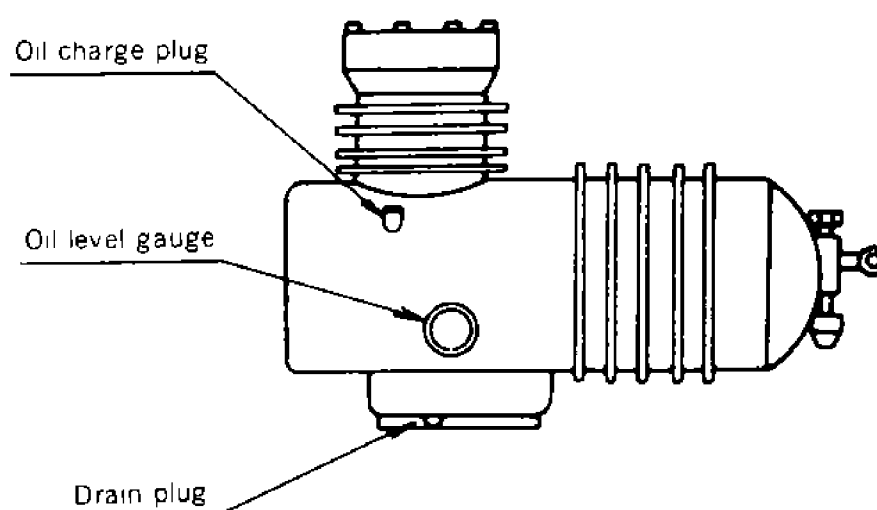

- 2) Tighten up the drain plug.
- 3) Charge the predesigned volume of the oil from the charge plug of the compressor.
- 4) Accomplish vacuum drying and refrigerant charge stated in (1).
- 5) Be sure to stop the compressor while this work is accomplished.
- 6) When the refrigeration oil is discarded, be sure to remove the oil level gauge for cleaning.
- 7) Recommendable refrigeration oil is SUNISO 3GS-DI. SUNISO 3GS-DI is superior to SUNISO 3GS in heat resistance. Maker of SUNINO 3GS-DI is SUN OIL CO., LTD. (U.S. A.)
- 8) Do not mix two refrigeration oils.
- 9) Do not use oil which is left opened to the atmosphere for a long time, as it may contain water. In case oil still remains in the oil can after charging, be sure to cap it.

- (c) In case only the refrigeration oil is exchanged.

- 1) Operate the refrigeration unit to pump down the refrigerant by use of the stop valve at the outlet of the water cooled condenser (or receiver) and stop it when low pressure becomes 0.1 kg/cm².
- 2) Tighten up the discharge valve of the compressor.
- 3) Open the gauge port on the suction side to extract the refrigerant on the low pressure side.
- 4) Charge the oil from the oil charge plug. At this time, form the vaccum gradually to hasten oil charge.
- 5) Restore the stop valve to its original state.

6.5 Check points for high pressure switch

Check the high pressure switch for functioning after stopping the condenser fans so as to raise discharge pressure. Remove the lead wire on the strip in the switch box to stop the condenser fans. After finishing the test, provide rewiring accurately as it was.

- LXE5A-C(T)
- LXE5A-CA(T)
- LXE5-CAT (MFG.NO.6800026~)

Air/water cooled type

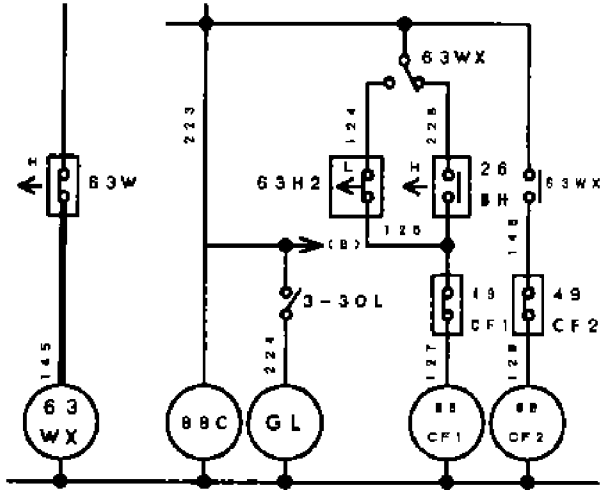

Air cooled type

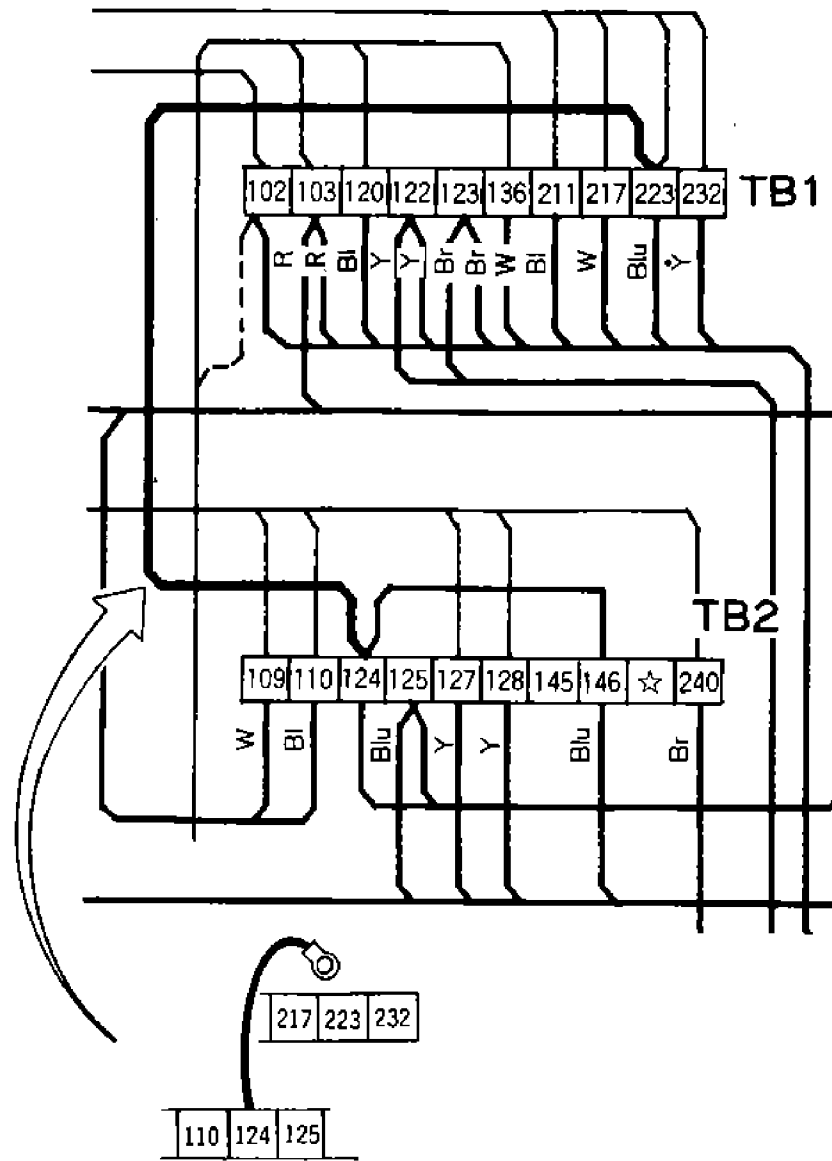
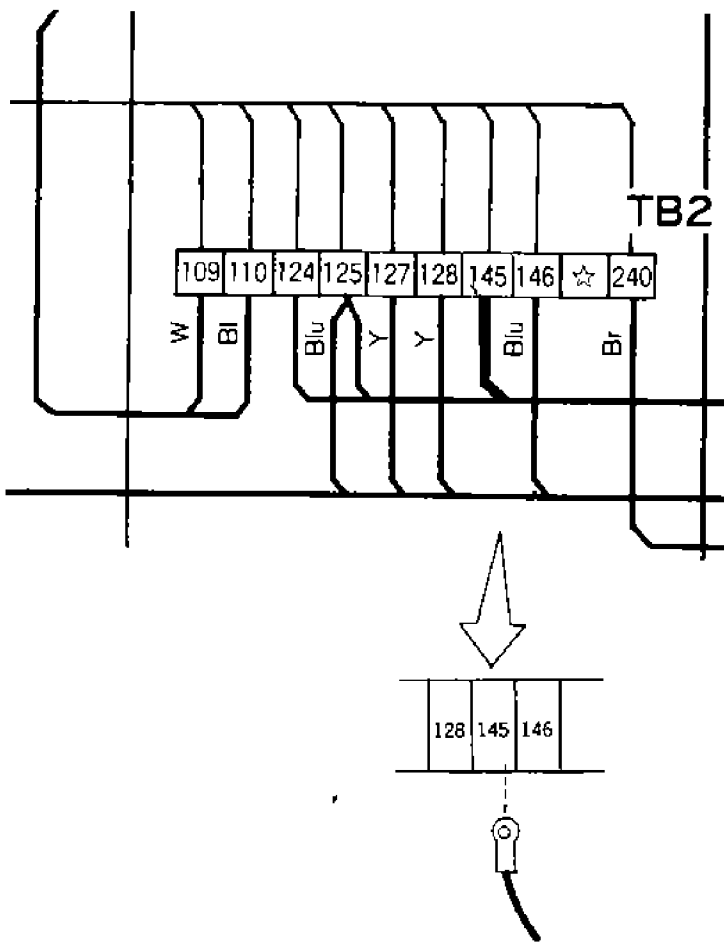
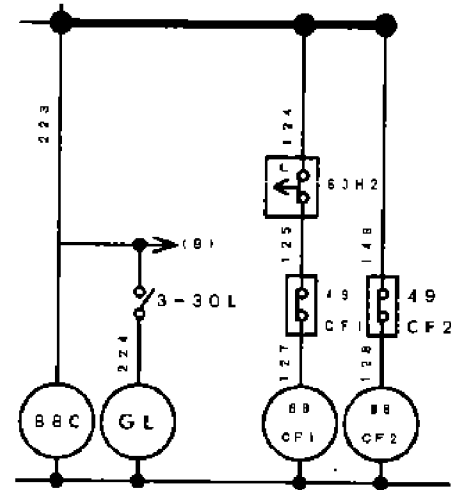

- LXE5-C (MFG.NO.6700001~6800052)
- LXE5-CAT (MFG. NO. 6700001~6700025)

Air/water cooled type

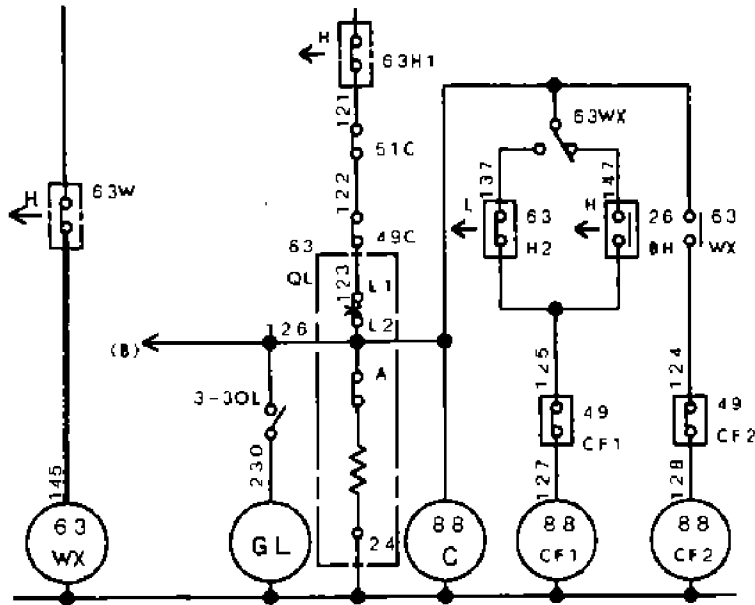

Air cooled type

