

**DAIKIN**  
**Marine type**  
**Container Refrigeration Unit**

---

**Service manual**

**Model**

**LXE8**  
**LXE8-A**

<https://daikin-p.ru>

This manual describes the features, functions, operation, and maintenance of the container refrigeration unit. In addition, the manuals listed below are also available.

● Parts list

Please refer also to these manuals.

## **DANGER**

1. Do not disconnect plug until power supply is shut off.
2. Do not touch the condenser fan during water cooled operation. (The condenser fan operates on and off to cool the control box.)

## **CAUTION**

Do not start the unit until a plug is connected and generator plant is operated.

## **NOTE**

1. Confirm the function of the temperature recorder and life of the battery when the chart paper is replaced with a new one.
2. Firmly tighten the cover of the control box not to make water ingress.
3. Confirm that the stop valves in the refrigeration circuit are opened before operation.
4. Confirm that the cargos are cooled down to the temperature for transportation in advance.
5. After operating the container refrigeration unit for service, wash the unit with fresh water, especially the external section of the unit carefully, because much salt sticks on the unit.

## Relevant models

The following models are described in this service manual.

Model	LXE8	LXE8-A
Inside air discharge direction	Bottom air discharge type	Bottom air discharge type
Condenser cooling type	Air/water cooled type	Air cooled type

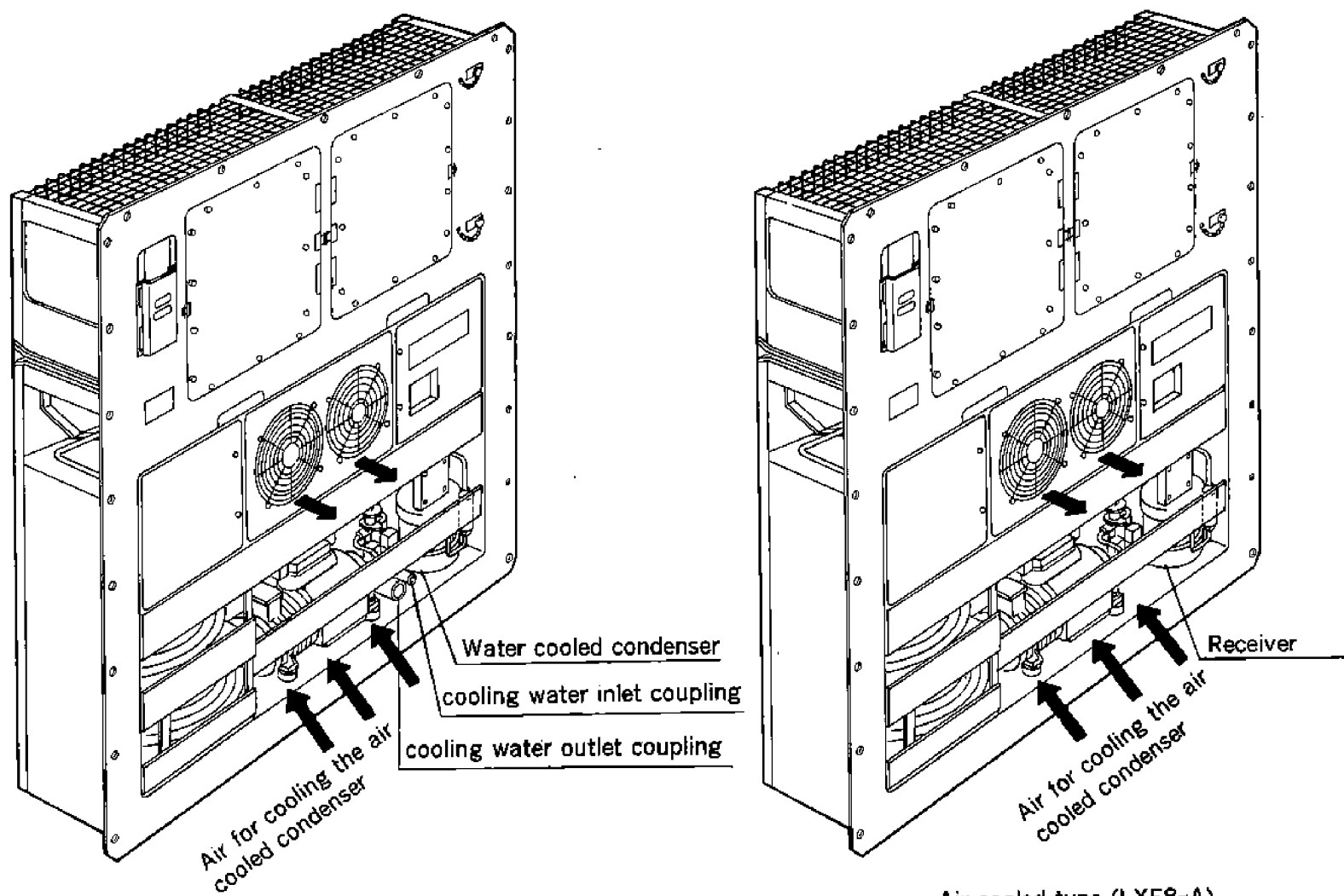

Air/water cooled type (LXE8)

Air cooled type (LXE8-A)

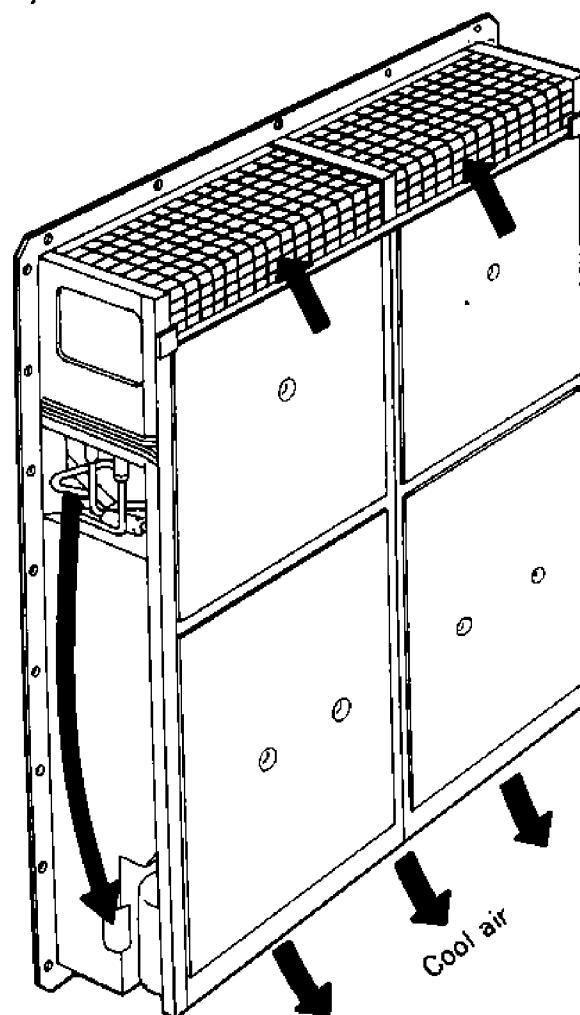

Bottom air discharge type (LXE8 LXE8-A)

Chapter for operation

1. Operation ranges .....	2
2. Names of parts .....	2
3. Operation .....	3
3.1 Preparation and operation .....	3
3.2 Checking during operation .....	6
3.3 Maintenance after operation .....	6
3.4 Switches and pilot lamps .....	7

Chapter for maintenance and repair

1. Data of the products .....	11
1.1 Main specifications .....	11
1.2 Names of parts .....	12
1.2.1 Outside .....	12
1.2.2 Inside .....	13
1.2.3 Switch box .....	14
1.2.4 Control box .....	15
1.3 Piping diagram .....	16
1.4 Electric wiring diagrams .....	17
1.4.1 Sequence .....	17
1.4.2 Actual wiring diagram .....	19
1.5 Set values of functional parts and protective devices .....	23
1.6 Operation pressure and running current .....	24
2. Operation modes and circuits .....	25
2.1 How to read wiring diagrams .....	25
2.2 High pressure control .....	27
2.3 Air cooled and water cooled operation (Air/water cooled type) .....	27
2.4 Voltage selection system .....	28
2.5 Frozen operation .....	30
2.6 Chilled operation · Partial frozen-capacity control .....	32
2.7 Defrost operation .....	34
2.8 Heat-up operation .....	36
2.9 Refrigerant flow at each operation mode .....	38
2.10 Pilot lamps and monitoring circuit .....	40
3. Trouble and countermeasures .....	41
4. PTI (Pretrip inspection) .....	43
5. Major components and maintenance .....	44
5.1 Components related with the refrigeration circuit .....	44
5.1.1 Compressor .....	44
5.1.2 Air cooled condenser and evaporator .....	44
5.1.3 Water cooled condenser (Air/water cooled type) .....	44
Receiver (Air cooled type) .....	
5.1.4 Expansion valve .....	45
5.1.5 Liquid/moisture indicator .....	46
5.1.6 Dryer .....	47
5.1.7 Solenoid valves .....	47
5.2 Components related with the air system .....	49
5.2.1 Fans and motors .....	49
5.2.2 Ventilator .....	49
5.3 Functional electric parts .....	50
5.3.1 High pressure switch (63H1) .....	50
5.3.2 Low pressure switch (63L) .....	50
5.3.3 High pressure control switch (63H2) .....	50
5.3.4 Water pressure switch (63W) (Air/water cooled type) .....	50
5.3.5 Oil pressure protection switch (63QL) .....	50
5.3.6 Recorder (SKM-2924A) .....	51
5.3.7 Phase sequence controller (47) .....	54
5.3.8 Electronic controller (DECOS) (23A) .....	55
6. Maintenance .....	63
6.1 Handling method of the stop valves .....	63
6.2 Attaching or removing points of pressure gauges .....	64
6.3 Pump down .....	65
6.4 Charging and purging the refrigerant, refrigeration oil .....	65
6.5 Check points for high pressure switch .....	67

<https://daikin-p.ru>

# **Chapter for operation**

## 1. Operation ranges

Use the units within the following ranges

Item	Operation range	
Ambient temperature range	-30°C~+50°C (-22°F~+122°F)	
Cooling water (air/water cooled type)	Quality of water	Fresh water
	Temperature	10°C~36°C (50°F~96.8°F)
	Water flow rate	20~46 ℓ /min.
	Pressure	2~5kg/cm <sup>2</sup>
Inside temperature range	-25°C~+25°C (-13°F~+77°F)	
Voltage	200V class 200V 50/60Hz, 220V 60Hz	
	400V class 380V~415V 50Hz, 400V · 440V 60Hz	
	Voltage fluctuation rate ±10%	
Vibration and shock	2G	

## 2. Names of parts

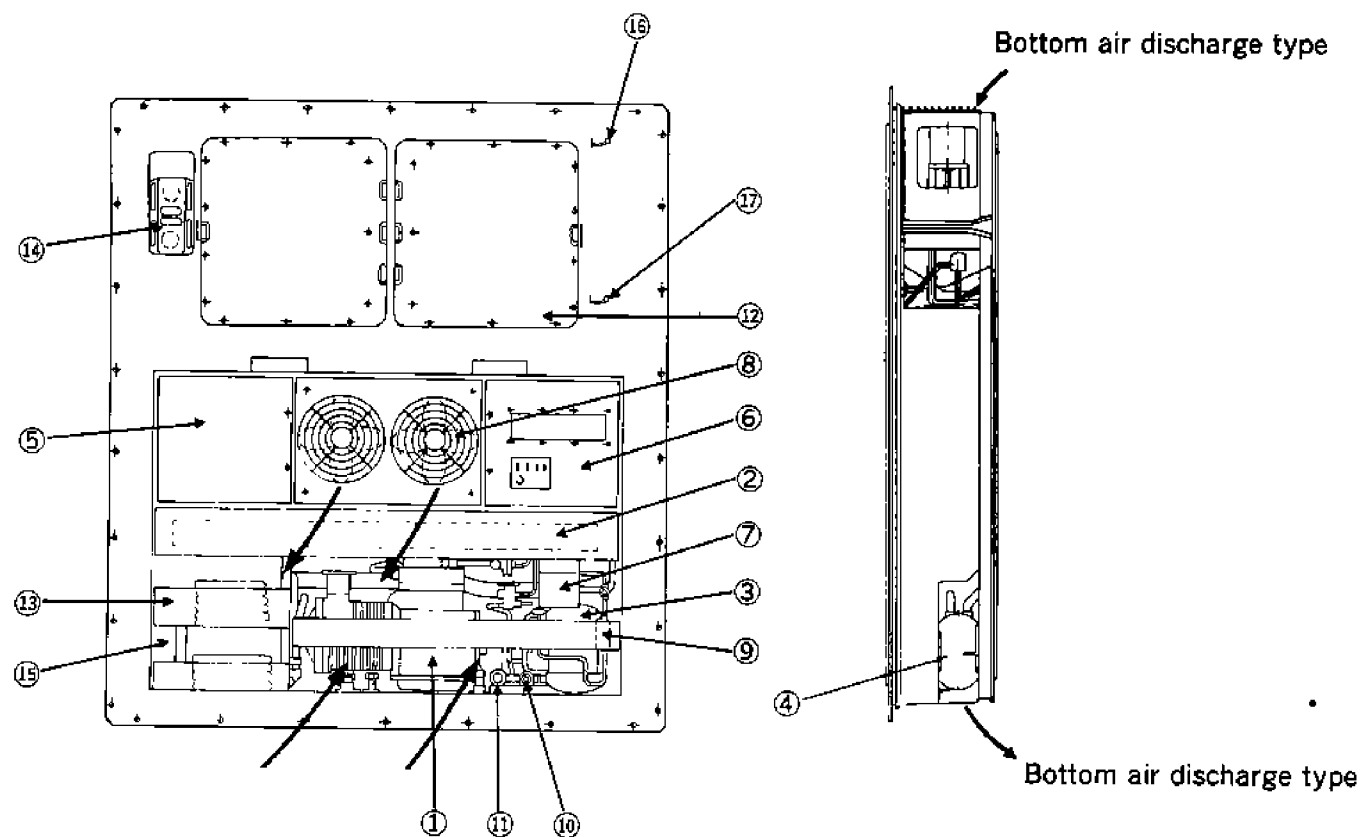

- |  |   |  |
|--|---|--|
| ① Compressor   | ⑩ Cooling water inlet coupling  | } [Connect the water piping to them before water cooled operation, and air cooled operation is automatically changed to water cooled operation.] |
| ② Air cooled condenser   | ⑪ Cooling water outlet coupling (Air/water cooled type)   |  |
| ③ Water cooled condenser (Air/water cooled type) Receiver (Air cooled type)  |   |  |
| ④ Accumulator  |   |  |
| ⑤ Switch box   |   |  |
| [Breaker for main circuit, breaker for control circuit voltage selector switch are installed in the box.]                      |   |  |
| ⑥ Control box  | ⑫ Access panel  |  |
| [On the front, the operation switches are arranged, and controller and recorder are installed inside.]                         | ⑬ Storage space for power cable   |  |
| ⑦ Oil pressure protection switch box   | ⑭ Ventilator  |  |
| ⑧ Air cooled condenser fans  | ⑮ Transformer   |  |
| [Operate during air cooled operation. Note that they sometimes operate to cool the control box during water cooled operation.] | ⑯ Thermometer check point   |  |
| ⑨ Dryer  | ⑰ Gas sampling port   |  |
|  | ○ Thermometer check point (Use this port to measure inside temperature)                         |  |
|  | ○ Gas sampling port (Use this port to measure concentration of CO <sub>2</sub> in the storage.) |  |



### 3. Operation

Operate the unit by the procedures given below.

- Preparation and operation
- Checking during operation
- Maintenance after operation

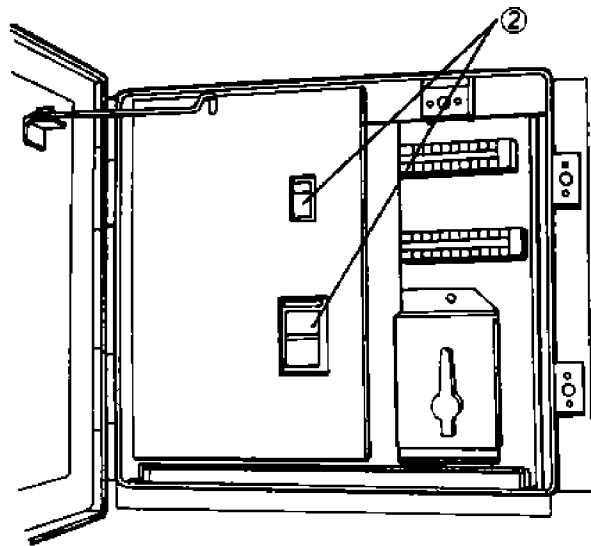

#### 3.1 Preparation and operation

##### Confirm that supply power is off.

Confirm that the power source ①, the circuit breaker ② and unit ON-OFF switch ③ are turned off before checking for safety's sake.

##### Confirming function of drive for the recording chart

- Confirming life of a dry element battery  
Press the push button ⑦ and confirm that the needle of the remaining voltage indicator ⑧ remains in the blue zone. (The meter functions only when the push button ⑦ is pressed down)
- Confirming the function of quartz motor  
After confirming the life of dry element battery, check through the inspection window ⑨ the inside fly wheel is rotating.

##### Setting a sheet of recording paper

- Raise the pen by the pen holder ④, loosen the chart nut ⑥, and set a new sheet of recording paper.
- Set the date on the paper to an arrow of present time plate ⑤.
- Firmly tighten up the chart nut ⑥ and release the pen so that recording can be accomplished.

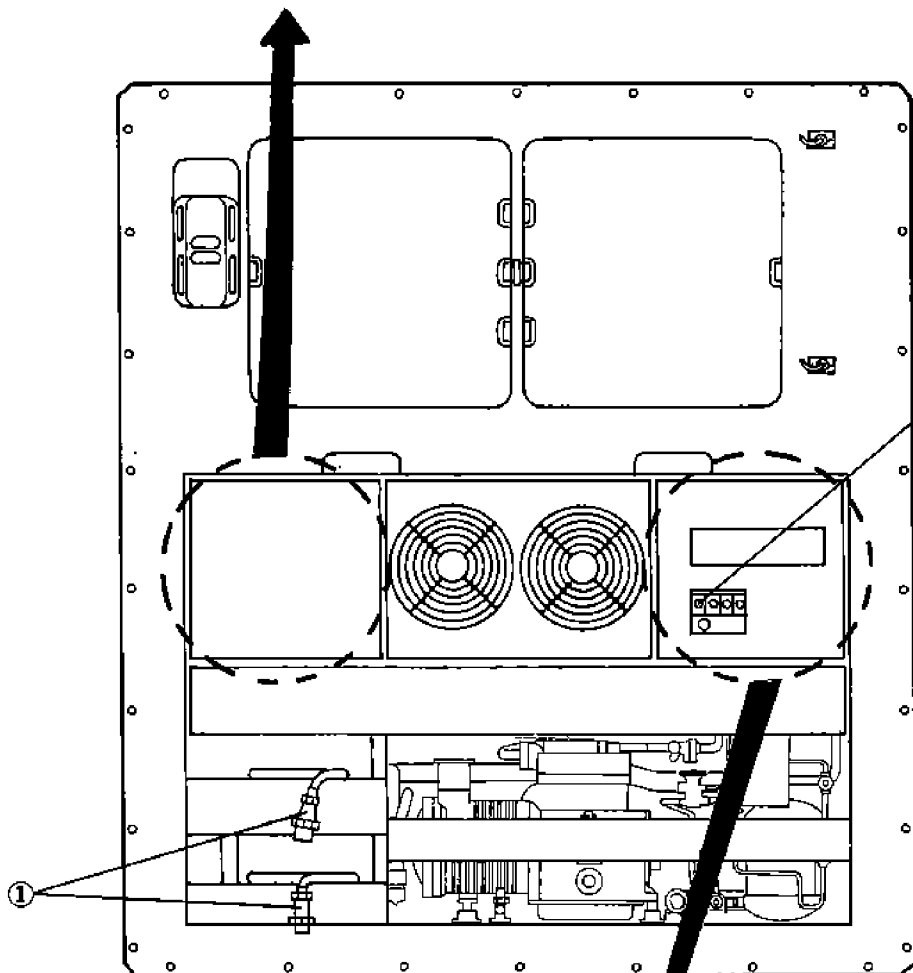

- |                      |  |
|----------------------|--|
| ④ Pen lifting arm    | ⑦ Push button  |
| ⑤ Present time plate | ⑧ Remaining voltage indicator                            |
| ⑥ Chart nut          | ⑨ Inspection window for checking of quartz motor running |



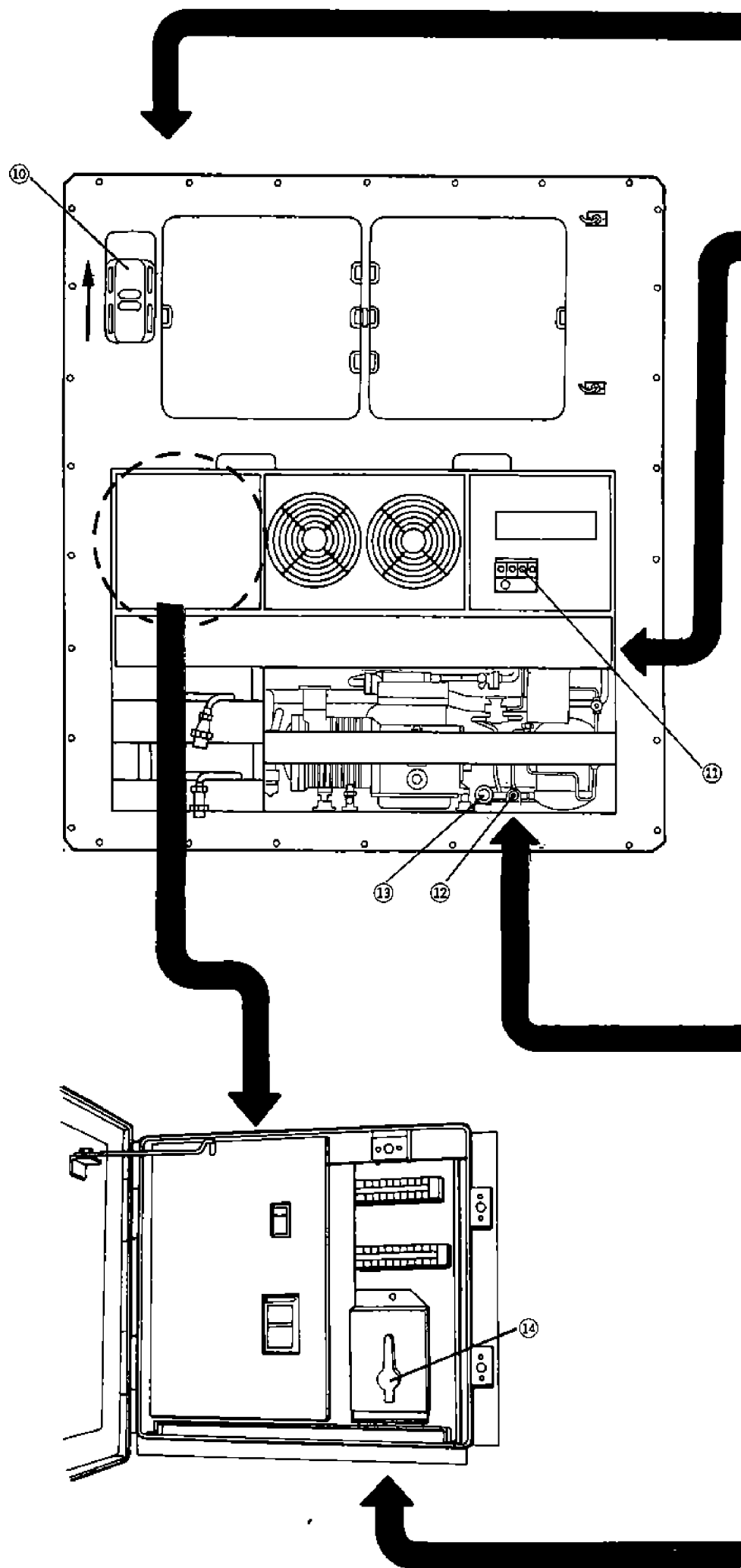

**Open or close the ventilator.**

Open or close the ventilator ⑩ according to the cargo. (Be sure to keep it closed during transportation of frozen cargo.)

**Reset the oil pressure protection switch.**

Reset by turning on the switch ⑪ on the front panel of the control box. The unit does not start unless the switch is reset.

**Connect the cooling water piping. (Air/water cooled type)**

- In the case of water cooled operation, connect the water piping, and supply water through it.

- Connecting method

1. Connect the cooling water inlet coupling ⑫.
2. Connect the cooling water outlet coupling ⑬.

- Disconnecting method.

1. Disconnect the cooling water outlet coupling ⑬.
2. Disconnect the cooling water inlet coupling ⑫.

When the cooling water couplings are connected, insert the coupling on the ship side into the coupling on the unit side until a "click" is heard.

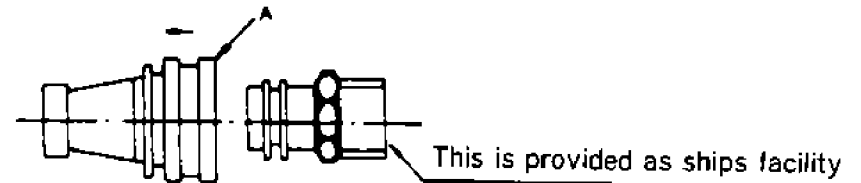

When disconnecting them, pull the coupling on the ship side toward you while pushing the "A" part of the female coupling in the direction pointed by an arrow mark.

Both at connecting and disconnecting, be careful for splash of cooling water.

**Check that all refrigerant stop valves are opened.**

**Set the voltage selector ⑭ according to the supply voltage.**

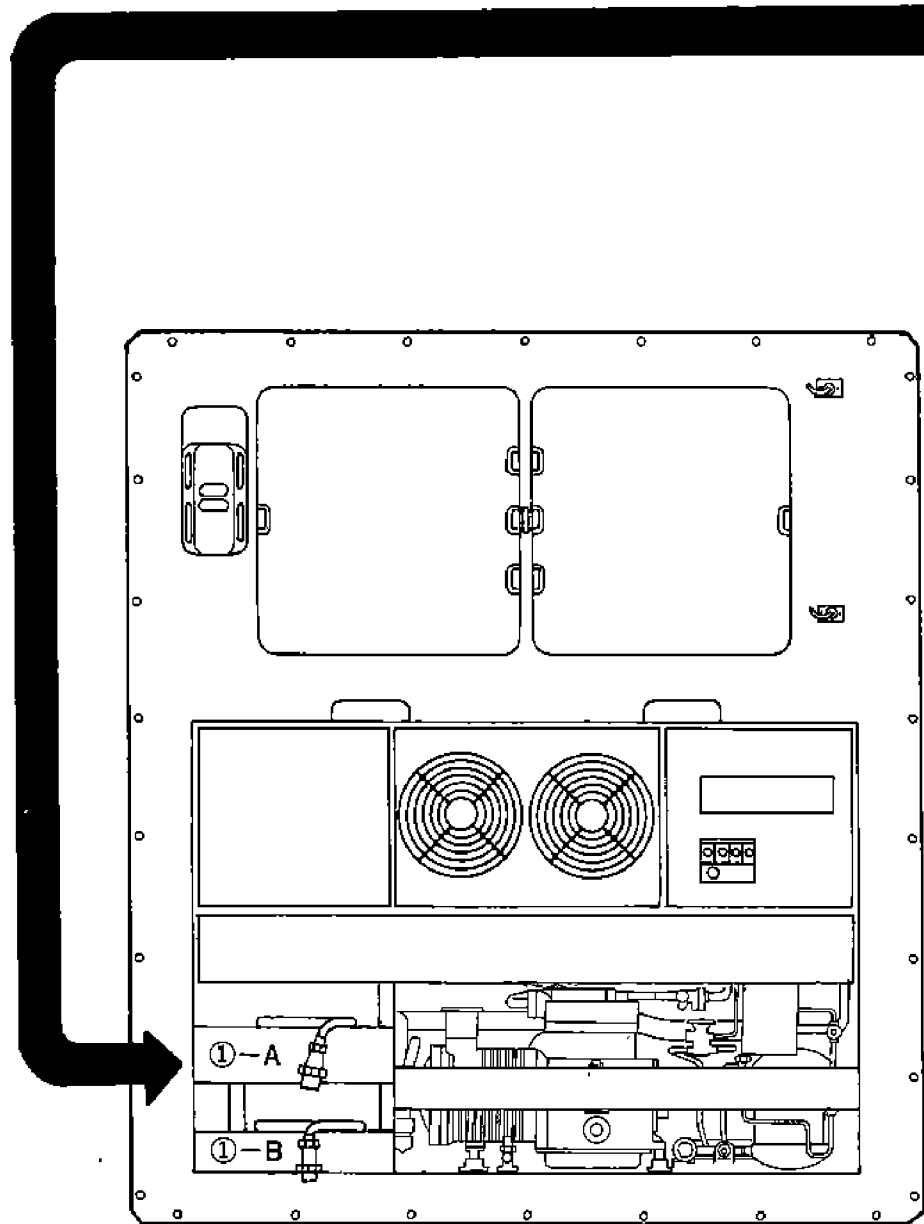

Plug ① in the power source which supplies the proper voltage, and fasten the plug ① firmly.

Turn on the power switch of the facility (outside the unit).

Turn ON the circuit breaker ② and unit ON-OFF switch ①.

Close the cover of the control box.  
If it is loose, water will intrude. Check around the packing and tighten the cover securely

- ① power plug
- ①-A 200V class
- ①-B 400V class

**Note:** If the unit stops 2~3 minutes later after starting, the oil pressure protection switch may be activated in many cases.  
(At this time, the check lamp (LED) on the electronic controller blinks. So depress the indication selector switch to make the lamp for "CHECK" light up, and "EOP" for function of activation of the oil pressure switch is displayed.)  
At this time, turn on the oil pressure reset switch ⑪ (3-QL). The operation is automatically started after 2 minutes. (If the switch is turned on within 2 minutes after the oil pressure switch is energized, the EOP display flickers.) If the unit stops again, repeat the above procedures.

### 3.2 Checking during operation

Checking items (precautions)	Method of check
1. Check if unusual noise and vibration is not produced from compressor, fan and piping etc.	Visual, listening and touching.
2. Check to ensure oil pressure protection switch does not function, and the unit does not stop.	—
3. Check suction and discharge pressures of the compressor. (For installation of a gauge, refer to Section 6 "Maintenance".)	Compare observed data with standard ones.
4. Check for proper oil level of compressor. Check to see the oil is clean. (Oil level may fall for a while after starting, but it rises gradually.)	Visual Oil level should be approx. $\frac{1}{4}$ to $\frac{3}{4}$ of its full scale.
5. Check to see if refrigerant is sufficient. (The refrigerant bubbles immediately after starting, but this does not mean that refrigerant is lacking.)	Shortage of refrigerant is indicated by bubbles in the moisture indicator.
6. Check if any moisture is present in refrigerant circuit. (The color of moisture indicator may turn to orange if it has been exposed to gaseous refrigerant for a long time, but this is no indication of trouble.)	Visual The moisture indicator should normally appear deep blue. Orange color is a sign of trouble.
7. Check if the recorder operates according to the inside temperature.	Visual
8. Check operating conditions with the pilot lamps and check instrument	Visual

### 3.3 Maintenance after operation

#### Stopping

To stop the unit, perform defrosting operation with the manual defrost switch and immediately turn off the unit ON-OFF switch after the compressor has stopped, (stop the unit with "pump-down" state.)  
After pump down, turn off the circuit breaker.

#### Stowing the power cable

Turn the plug's opening downward so that sea and rain water cannot enter the plug when stowing it.

Close the cover of the control box.

After water cooled operation, remove the water piping. (Air/water cooled type)

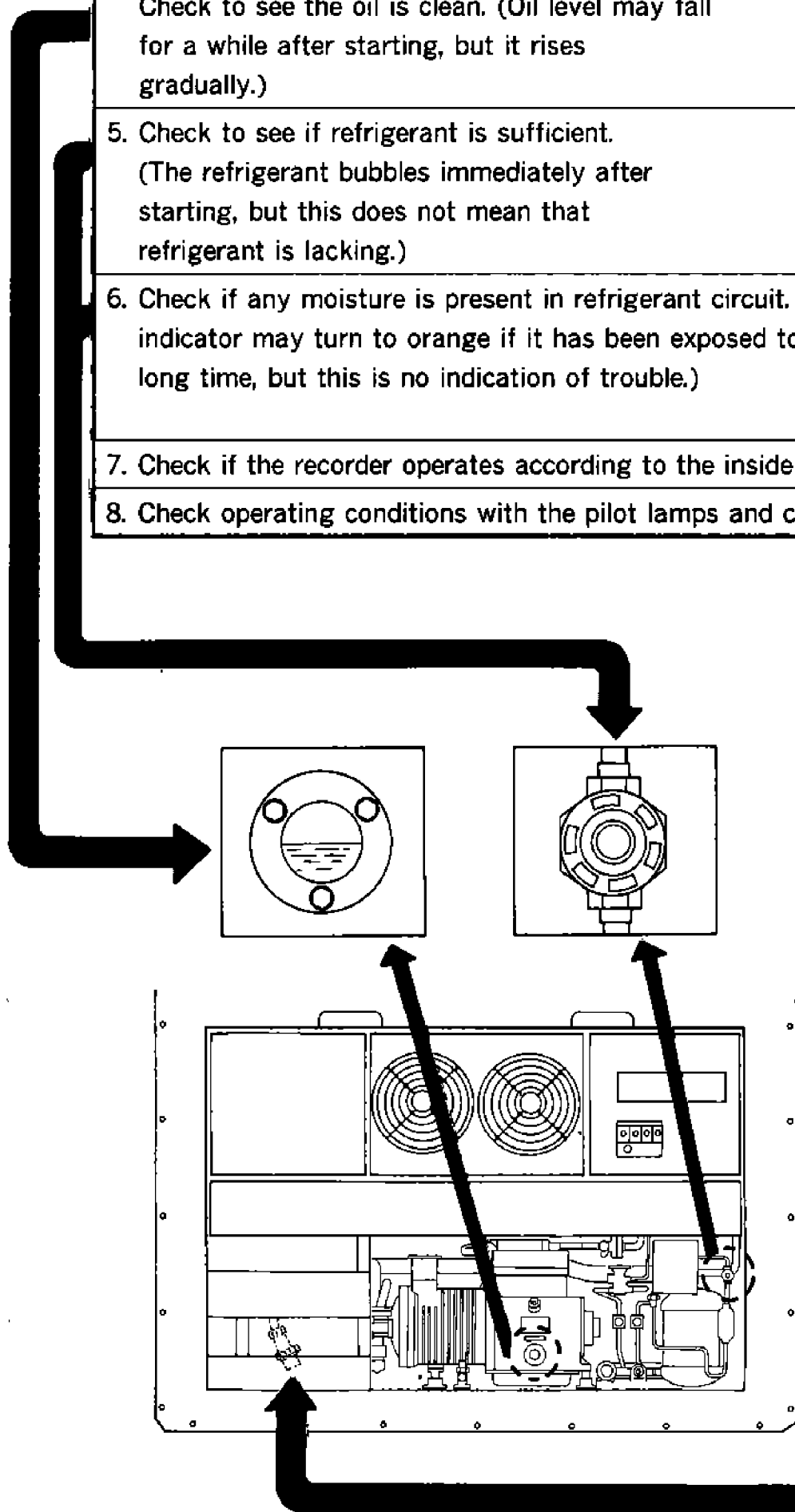

**3.4 Operation switches and pilot lamps**

Pilot lamp	Colors	Function
COMP.	Green	Lights up during compressor operation.
DEFROST	Red	Lights up during defrosting.
IN RANGE	Orange	Lights up while maintaining optimum temperature ( $-2.0^{\circ}\text{C}$ [ $-3.6^{\circ}\text{F}$ ] $< \text{SP} < +2.0^{\circ}\text{C}$ [ $+3.6^{\circ}\text{F}$ ])

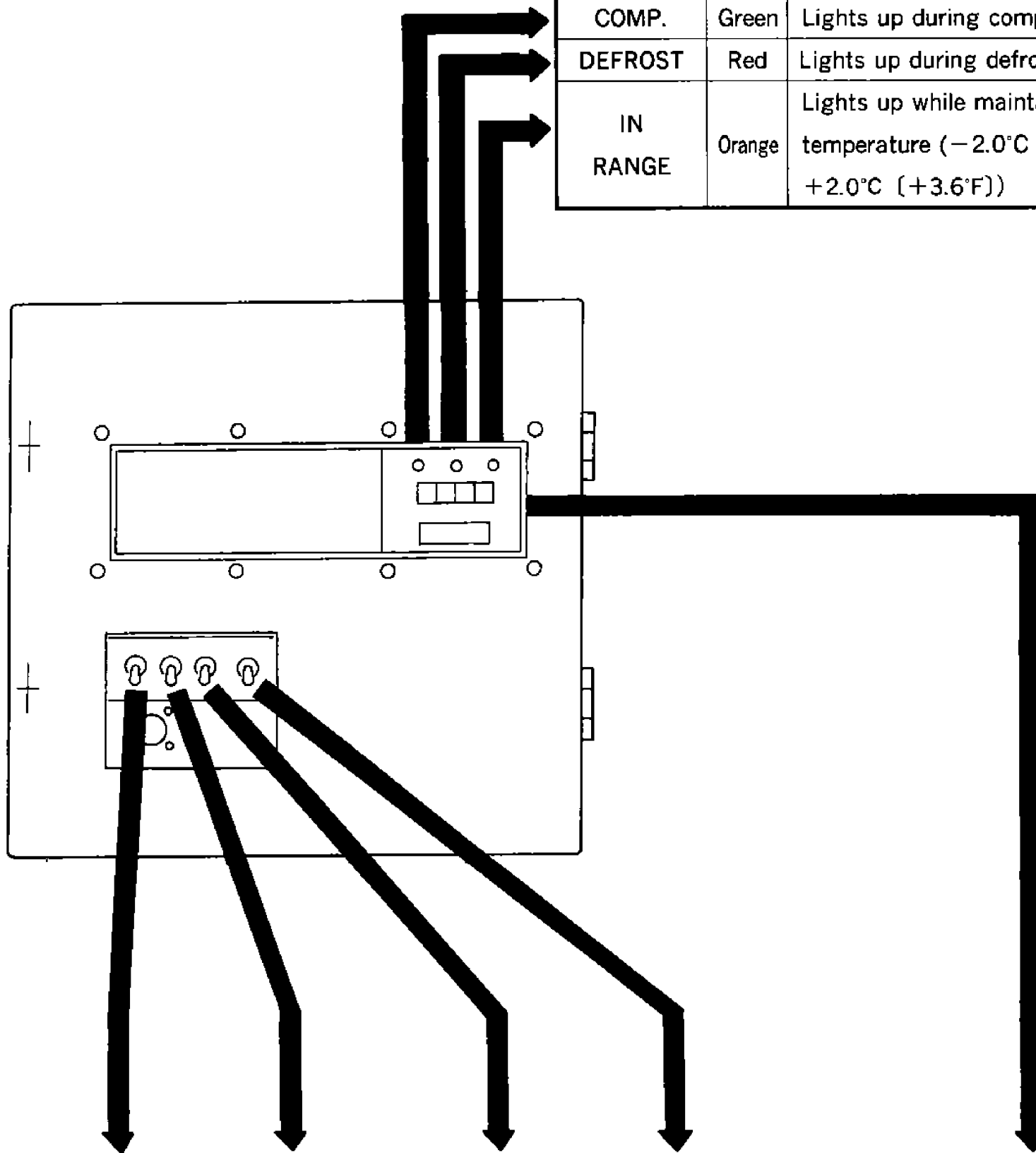

Switches	Unit ON-OFF	Defrost AUTO/MANUAL		OPS RESET	Pilot lamp ON-OFF	Set point selector		
Operation mode	_____	Defrosting		_____	_____	Chilled operation	Partial frozen operation	Frozen operation
Operation points	Turn on the switch	Automatic Defrosting begins and terminates automatically by the timer S : 4Hr L : 12Hr	Manual Turn on the switch.	Set the switch to RESET.	Turn on the switch.	Set the selector within $+25.0 \sim -2.9^{\circ}\text{C}$ . ( $+77 \sim +26.8^{\circ}\text{F}$ )	Set the selector within $-3.0 \sim -10^{\circ}\text{C}$ . ( $+26 \sim +14^{\circ}\text{F}$ )	Set the selector within $-10.1 \sim -25.0^{\circ}\text{C}$ . ( $+13.8 \sim -13^{\circ}\text{F}$ )
Functions	Operate the unit on and off.	Hot gas defrosting begins. When defrosting is terminated, chilled or frozen operation will begin automatically.		The oil pressure protection switch is reset.	Pilot lamp lights up.	Chilled operation begins. Inside temperature is controlled in PID by the supply sensor.  The evaporator fan is running in high speed when controlled air temperature is below $15^{\circ}\text{C}$ ( $59^{\circ}\text{F}$ ).	Partial frozen operation begins. Inside temperature is controlled in PID by the return sensor.	Frozen operation begins. Inside temperature is controlled in ON/OFF operation by the return sensor.  The evaporator fan is running in low speed.

<https://daikin-p.ru>

## **Chapter for maintenance and repair**

## 1. Data of the products

### 1.1 Main specifications

Item	Model	LXE8	LXE8—A
Inside air discharge direction		Bottom air discharge type	Bottom air discharge type
Condenser cooling methods		Air/water cooled type	Air cooled type
Power supply		AC 200V            3 Phase 50Hz AC 200V, 220V    3 Phase 60Hz AC 380~415V      3 Phase 50Hz AC 400V, 440V    3 Phase 60Hz (Dual-rating voltage system by voltage selector switch)	
Compressor		Semi hermetic type (5.5 kW)	
Evaporator		Cross finned coil type	
Air cooled condenser		Cross finned coil type	
Water cooled condenser		Vertical shell type	—
Fan		Motor direct driven propeller type	
Fan motor		Three-phase squirrel-cage induction motor	
Defrost			
Heating		Hot-gas defrost	
Initiation		Timer or manual switch	
Termination		Sensing suction pipe temperature by the defrost termination thermistor	
Refrigerant control		Thermostatic expansion valve	
Capacity control		Hot gas bypass control with modulating control valve	
Protection devices		Circuit breaker, over-current relay, compressor protective thermostat, fan motor protective thermostat, oil pressure protection switch, high pressure switch, and fusible safety plug	
Refrigerant (charged amount)		R12 : 6.0 (kg)/13.3 (lbs)	
Lubricant (charged amount)		SUNISO 3GS-DI : 4.0 ( ℓ )	
Weight		Approx. 675 (kg)/1488 (lbs)	Approx. 670 (kg)/1477 (lbs)

## 1.2 Names of parts

### 1.2.1 Outside

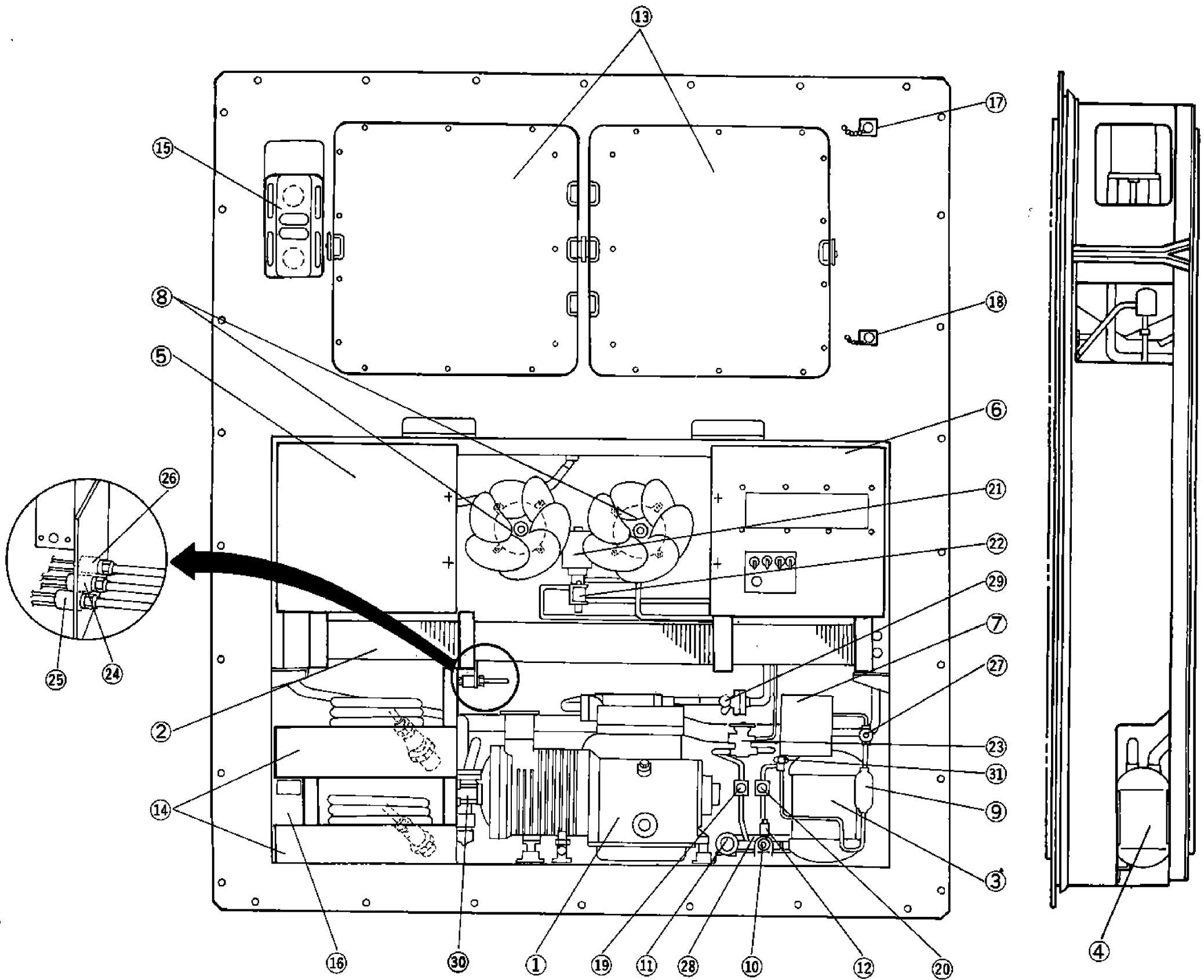

- |   |   |  |
|---|---|--|
| ① Compressor  | ⑭ Storage space for power cable<br>(Upper stage: 200V Class<br>Lower stage: 400V Class) | ⑳ Stop valve at compressor suction side                          |
| ② Air cooled condenser  | ⑮ Ventilator  | ㉑ Stop valve at water cooled condenser<br>(receiver) outlet side |
| ③ Water cooled condenser (Air/water<br>cooled type)<br>Receiver (Air cooled type) | ⑯ Transformer   |  |
| ④ Accumulator   | ⑰ Thermometer check point   |  |
| ⑤ Switch box  | ⑱ Gas sampling port   |  |
| ⑥ Control box   | ⑲ Main liquid solenoid valve (20R1)   |  |
| ⑦ Oil pressure protection switch box  | ⑳ Measuring liquid solenoid valve (20R2)  |  |
| ⑧ Air cooled condenser fan motor  | ㉑ Hot gas modulating control valve (20M)  |  |
| ⑨ Dryer   | ㉒ 3 way solenoid valve (20R3)   |  |
| ⑩ Cooling water inlet<br>coupling   | ㉓ Expansion valve   |  |
| ⑪ Cooling water<br>outlet coupling  | ㉔ High pressure switch (63H1)   |  |
| ⑫ Water pressure<br>switch(63W)   | ㉕ Low pressure switch (63L)   |  |
| ⑬ Access panel  | ㉖ High pressure control switch (63H2)   |  |
|   | ㉗ Liquid/moisture indicator   |  |
|   | ㉘ Accumulator (for defrosting)  |  |
|   | ㉙ Stop valve at compressor discharge side   |  |



1.2.2 Inside

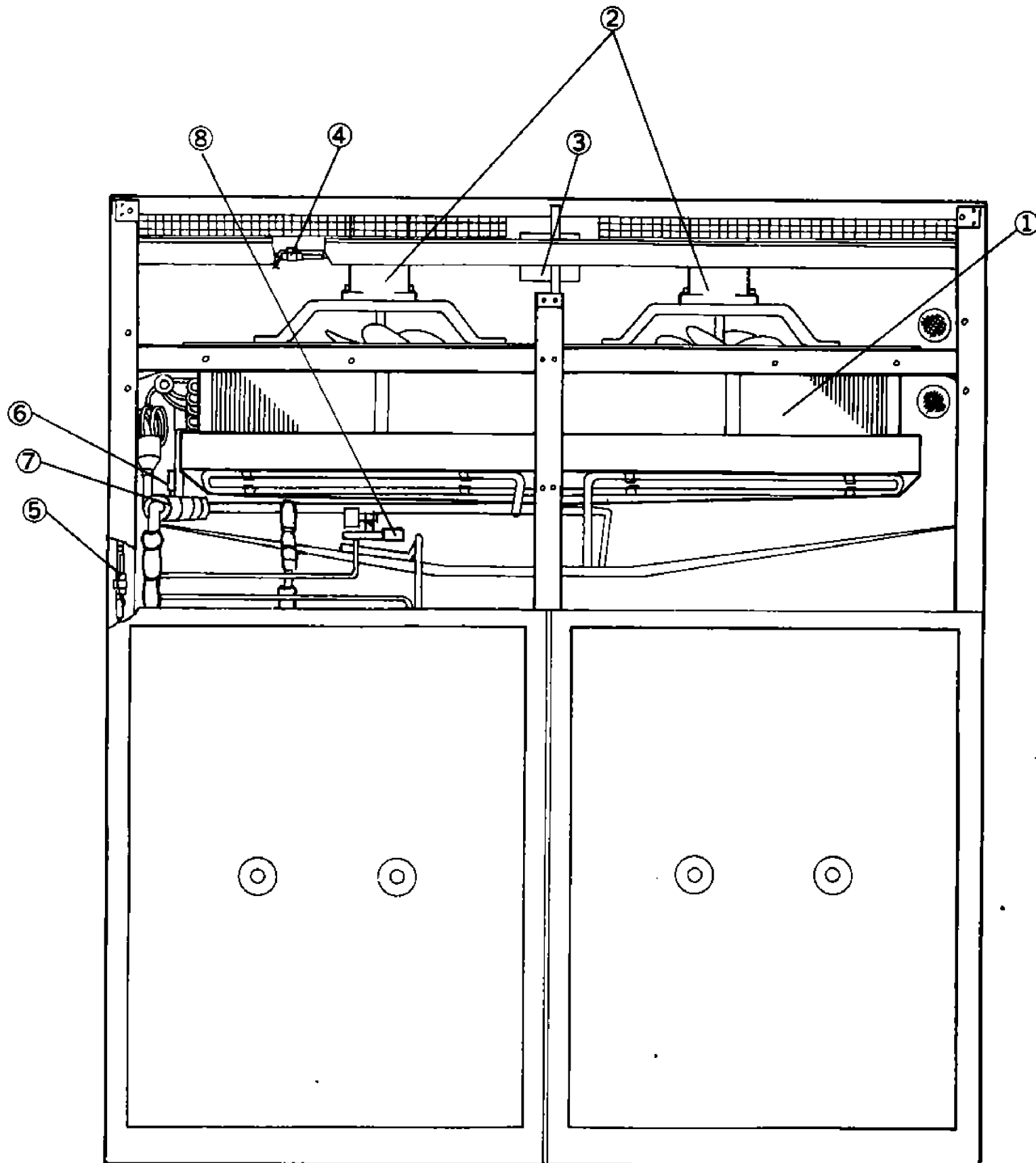

- ① Evaporator
- ② Evaporator fan motor
- ③ Junction terminal box
- ④ Return sensor and feeler tube (recorder)
- ⑤ Supply sensor
- ⑥ Defrost termination thermistor
- ⑦ Feeler tube (expansion valve)
- ⑧ 3 way solenoid valve for drain pan heater (20R4)

1.2.3 Switch box

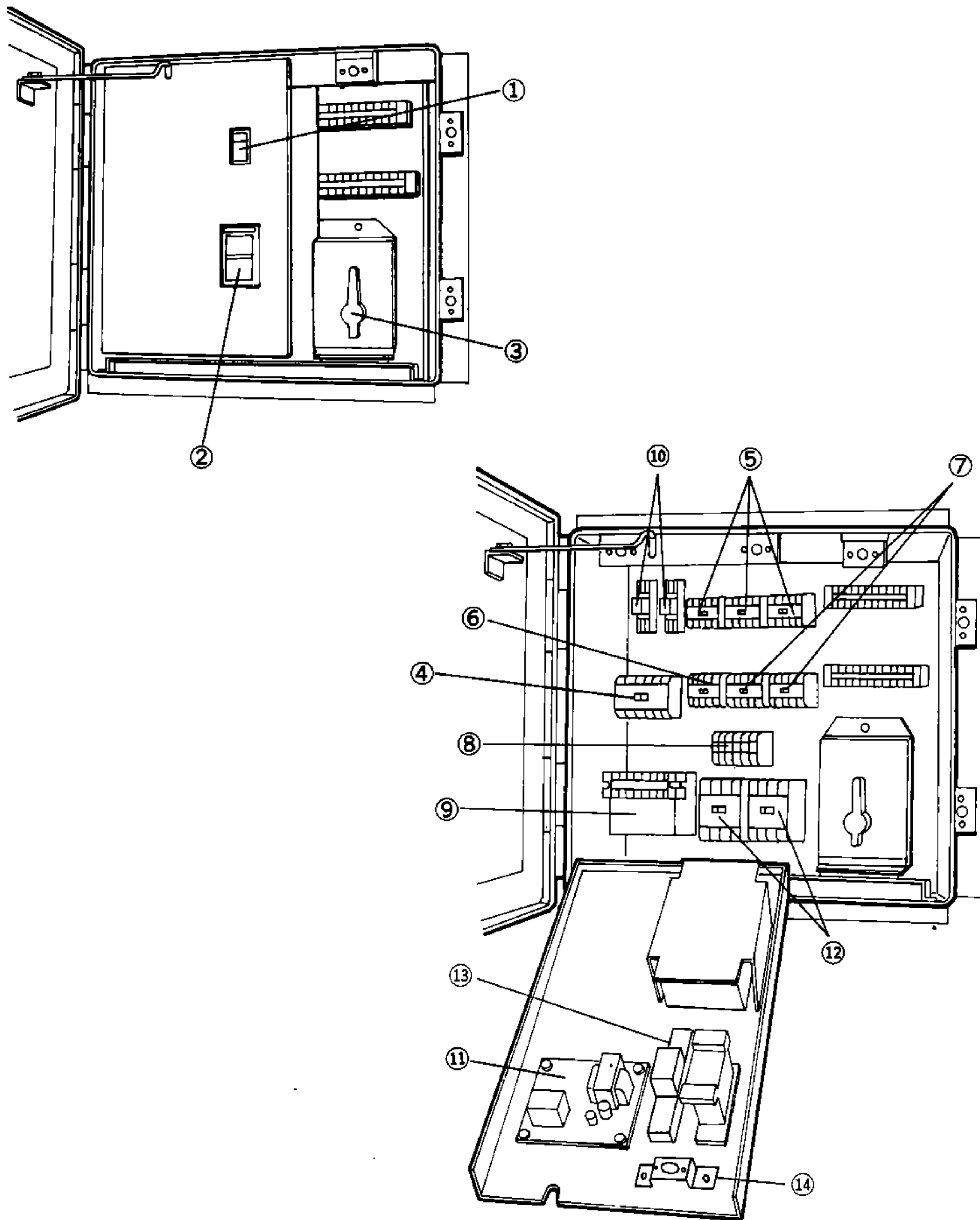

- |  |                                  |                         |
|--|----------------------------------|-------------------------|
| ① Circuit breaker (52C2)   | ⑪ Phase sequence controller (47) |                         |
| ② Circuit breaker (52C1)   | ⑫ Magnetic contactors (47X1 · 2) |                         |
| ③ Voltage selector switch (83)   | ⑬ Auxiliary relay (63WX)         | } Air/water cooled type |
| ④ Magnetic contactor for compressor (88C)                                  | ⑭ Switch box thermostat (26BH)   |                         |
| ⑤ Magnetic contactors for high speed evaporator fan motor (88EFH1 · 2 · 3) |                                  |                         |
| ⑥ Magnetic contactor for low speed evaporator fan motor (88EFL)            |                                  |                         |
| ⑦ Magnetic contactors for air cooled condenser fan motor (88CF1 · 2)       |                                  |                         |
| ⑧ Over-current relay (51C)   |                                  |                         |
| ⑨ Transformer (Tr2)  |                                  |                         |
| ⑩ Auxiliary relays (49EFX1 · 2)  |                                  |                         |

1.2.4 Control box

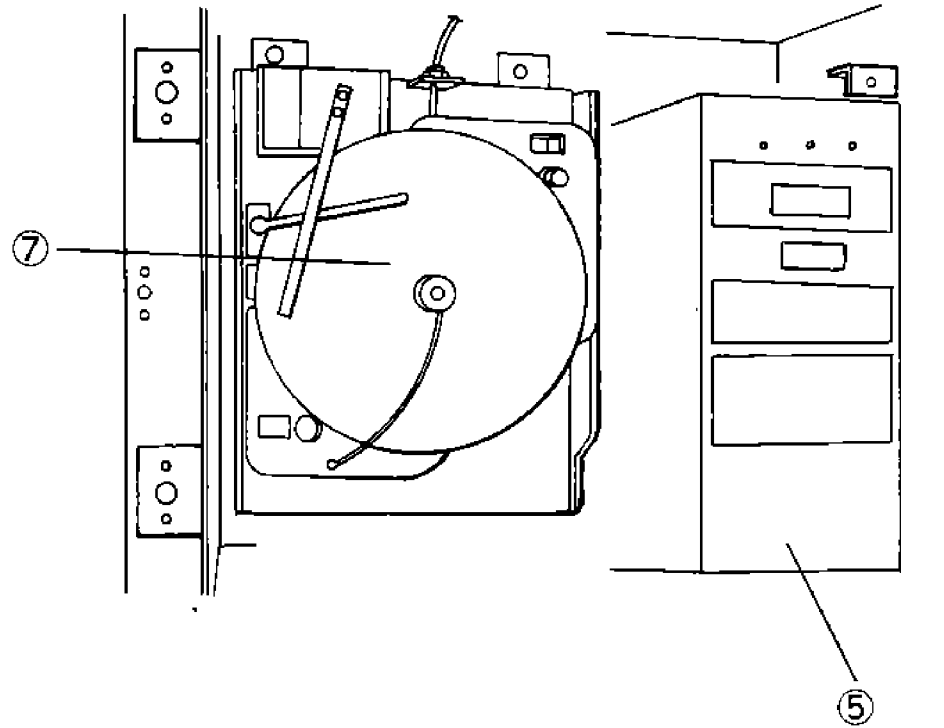
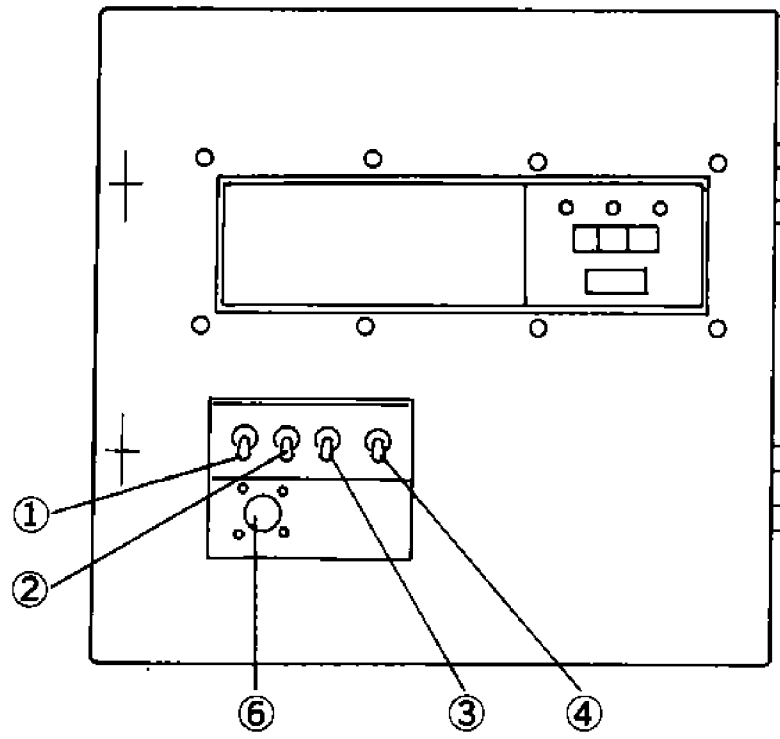

- ① Unit ON-OFF switch (3-88)
- ② MANUAL defrost switch (3D)
- ③ OPS reset switch (3QL)
- ④ ON-OFF pilot lamp switch (3-30L)
- ⑤ Electronic controller (23A)
- ⑥ Receptacle for monitoring
- ⑦ Recorder

**1.3 Piping diagram**

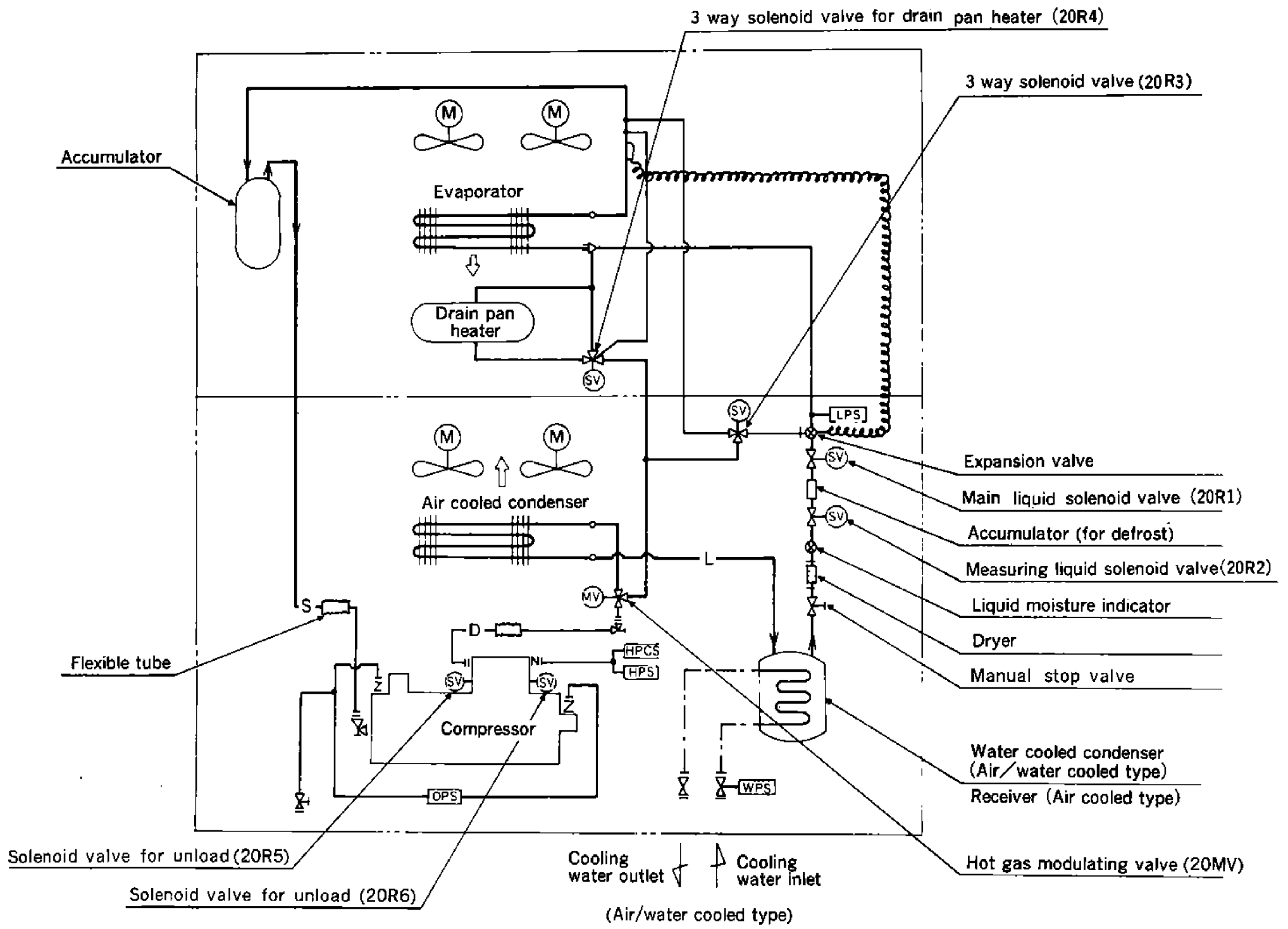

HPS (63H1)	HIGH PRESSURE SWITCH
LPS (63L)	LOW PRESSURE SWITCH
HPCS (63H2)	HIGH PRESSURE CONTROL SWITCH
OPS (63QL)	OIL PRESSURE PROTECTION SWITCH
WPS (63W)	WATER PRESSURE SWITCH (Air/water cooled type)

— L —	LIQUID PIPE
— S —	SUCTION PIPE
— D —	DISCHARGE PIPE
— + —	FLANGE CONNECTION
—   —	FLARE CONNECTION
— - - —	WATER PIPE

## CONTAINER REFRIGERATION UNIT WIRING DIAGRAM

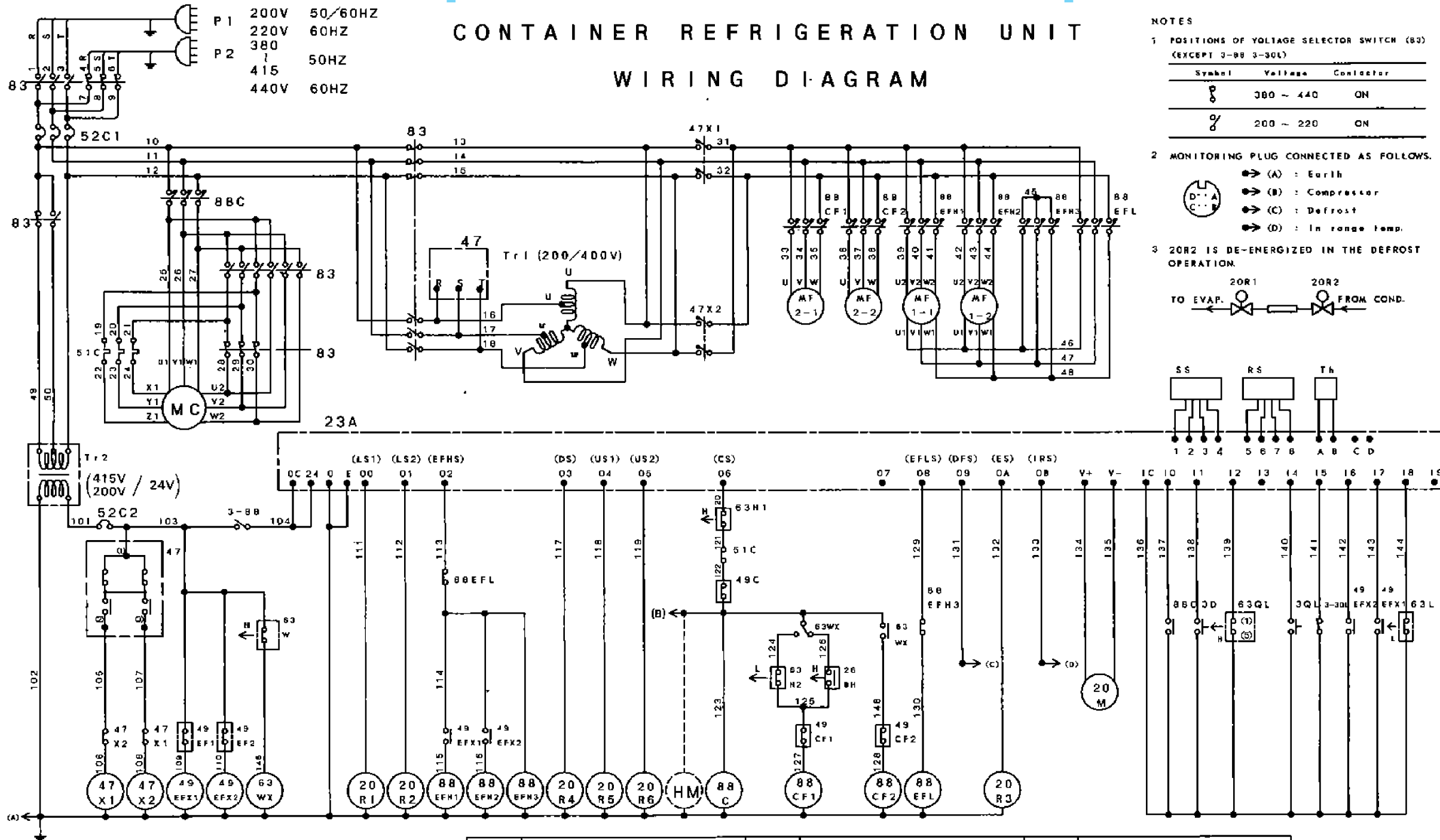

### NOTES

1 POSITIONS OF VOLTAGE SELECTOR SWITCH (83)  
(EXCEPT 3-88 3-30L)

Symbol	Voltage	Contactor
	380 ~ 440	ON
	200 ~ 220	ON

2 MONITORING PLUG CONNECTED AS FOLLOWS.

- (A) : Earth
- (B) : Compressor
- (C) : Defrost
- (D) : In range lamp.

3 20R2 IS DE-ENERGIZED IN THE DEFROST OPERATION.

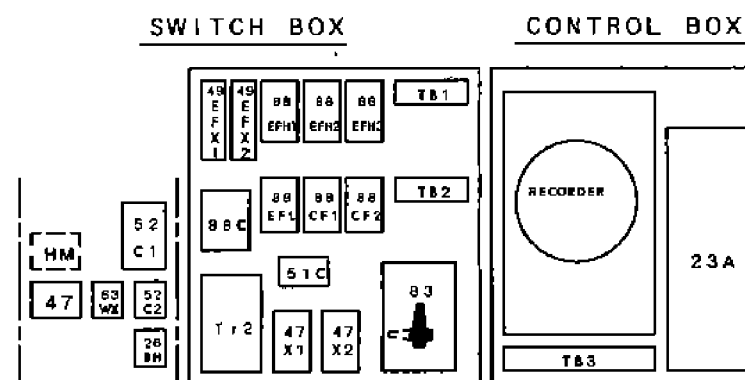

3-88	SWITCH (UNIT ON-OFF)	49CF	THERMO SWITCH (MF2)	MC	MOTOR (COMPRESSOR)
3-30L	SWITCH (LAMP)	49EF	THERMO SWITCH (MF1)	MF1	MOTOR (EVAP. FAN)
3D	SWITCH (MANUAL DEFROST)	49EFX	MAGNETIC RELAY	MF2	MOTOR (COND. FAN)
3QL	SWITCH (OPS RESET)	51C	OVER CURRENT RELAY (MC)	P	PLUG
20M	MODULATING VALVE	52C	CIRCUIT BREAKER	R. S.	RETURN AIR SENSOR
20R1	SOLENOID VALVE (DEF. TRAP1)	63H1	PRESSURE SWITCH (HIGH)	S. S.	SUPPLY AIR SENSOR
20R2	SOLENOID VALVE (DEF. TRAP2)	63H2	PRESSURE SWITCH (FAN CUT)	Tb	THERMISTOR (DEF. TERMINATION)
20R3	SOLENOID VALVE (EQUALIZE)	63L	PRESSURE SWITCH (LOW)	Tr1	TRANSFORMER (MF)
20R4	SOLENOID VALVE (DRAIN PAN)	63QL	PRESSURE SWITCH (OIL)	Tr2	TRANSFORMER (CONTROL)
20R6	SOLENOID VALVE (UNLOAD)	63W	PRESSURE SWITCH (WATER)		
20R8	SOLENOID VALVE (UNLOAD)	63WX	MAGNETIC RELAY		
23A	ELECTRONIC CONTROLLER	83	VOLTAGE SELECTOR SWITCH		
26BH	THERMO SWITCH (SWITCH BOX)	88C	MAGNETIC CONTACTOR (MC)		
47	PHASE-REVERSAL RELAY	88CF	MAGNETIC CONTACTOR (MF2)		OPTIONAL SPECIFICATION
47X	MAGNETIC CONTACTOR	88EFH	MAGNETIC CONTACTOR (MF1)	HM	HOUR METER
49C	THERMO SWITCH (MC)	88EFL	MAGNETIC CONTACTOR (MF1)		

### CAUTION

1. INSULATION TEST SHOULD NOT BE MADE TO CONTROL CIRCUIT (LINE NO. 101~ ).
2. -- SHOWS OPTIONAL SPEC. .

## CONTAINER REFRIGERATION UNIT WIRING DIAGRAM

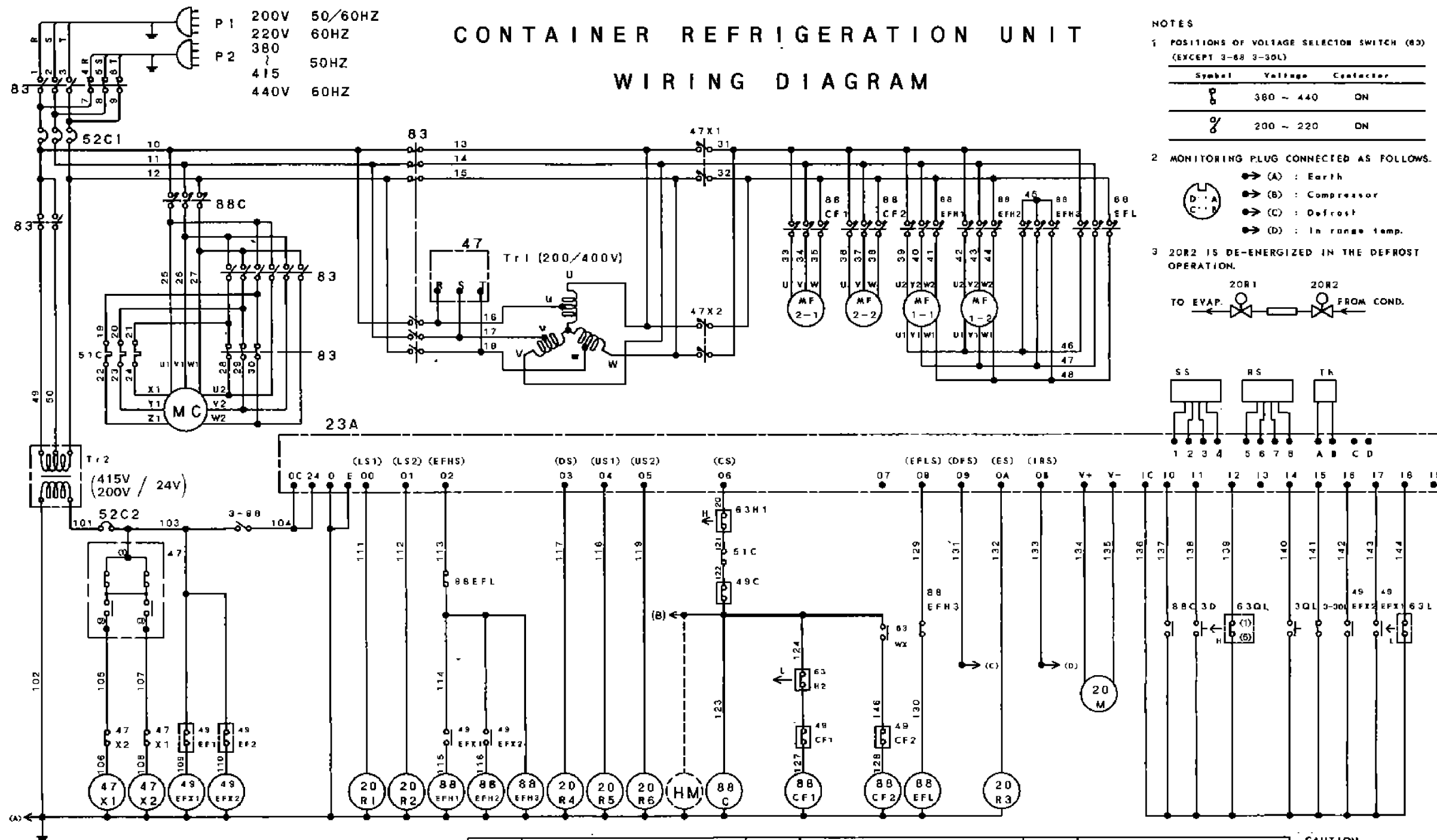

- NOTES**
- POSITIONS OF VOLTAGE SELECTOR SWITCH (83)  
(EXCEPT 3-68 3-30L)
- | Symbol | Voltage   | Contact |
|--------|-----------|---------|
|        | 380 ~ 440 | ON      |
|        | 200 ~ 220 | ON      |
- MONITORING PLUG CONNECTED AS FOLLOWS.
- | Terminal | Connection     |
|----------|----------------|
| (A)      | Earth          |
| (B)      | Compressor     |
| (C)      | Defrost        |
| (D)      | In range temp. |
- 20R2 IS DE-ENERGIZED IN THE DEFROST OPERATION.
- 

② LXE8-A

18

### SWITCH BOX

### CONTROL BOX

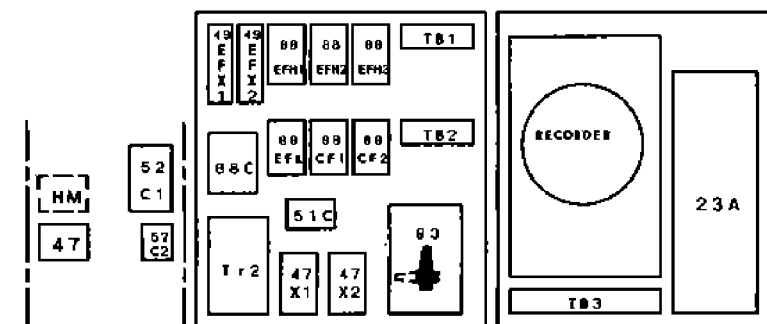

3-68	SWITCH (UNIT ON-OFF)	49CF	THERMO SWITCH (MF2)	MC	MOTOR (COMPRESSOR)
3-30L	SWITCH (LAMP)	49EF	THERMO SWITCH (MF1)	MF1	MOTOR (EVAP. FAN)
3D	SWITCH (MANUAL DEFROST)	49EFX	MAGNETIC RELAY	MF2	MOTOR (COND. FAN)
3QL	SWITCH (OPS RESET)	51C	OVER CURRENT RELAY (MC)	P	PLUG
20A	MODULATING VALVE	52C	CIRCUIT BREAKER	R. S.	RETURN AIR SENSOR
20R1	SOLENOID VALVE (DEF. TRAP1)	63H1	PRESSURE SWITCH (HIGH)	S. S.	SUPPLY AIR SENSOR
20R2	SOLENOID VALVE (DEF. TRAP2)	63H2	PRESSURE SWITCH (FAN CUT)	Th	THERMISTOR (DEF. TERMINATION)
20R3	SOLENOID VALVE (EQUALIZE)	63JL	PRESSURE SWITCH (LOW)	Tr1	TRANSFORMER (MF)
20R4	SOLENOID VALVE (DRAIN PAN)	63QL	PRESSURE SWITCH (OIL)	Tr2	TRANSFORMER (CONTROL)
20R5	SOLENOID VALVE (UNLOAD)				
20R6	SOLENOID VALVE (UNLOAD)				
23A	ELECTRONIC CONTROLLER	83	VOLTAGE SELECTOR SWITCH		
		88C	MAGNETIC CONTACTOR (MC)		
47	PHASE-REVERSAL RELAY	88CF	MAGNETIC CONTACTOR (MF2)		OPTIONAL SPECIFICATION
47X	MAGNETIC CONTACTOR	88EFH	MAGNETIC CONTACTOR (MF1)	HM	HOUR METER
49C	THERMO SWITCH (MC)	88EFL	MAGNETIC CONTACTOR (MF1)		

- CAUTION**
- INSULATION TEST SHOULD NOT BE MADE TO CONTROL CIRCUIT (LINE NO. 101~ ).
  - SHOWS OPTIONAL SPEC.
  - SHOWS JUMPER WIRE.

## 1.4.2 Actual wiring diagram ① LXE8

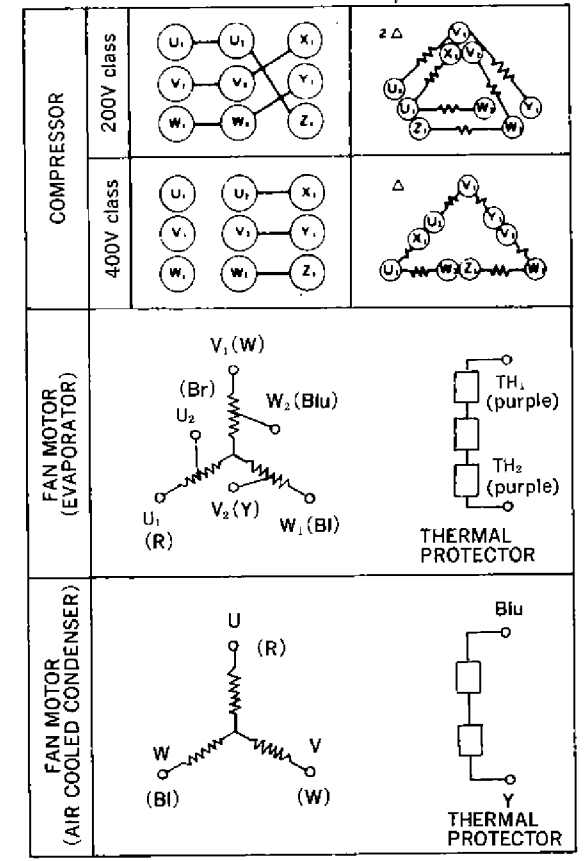
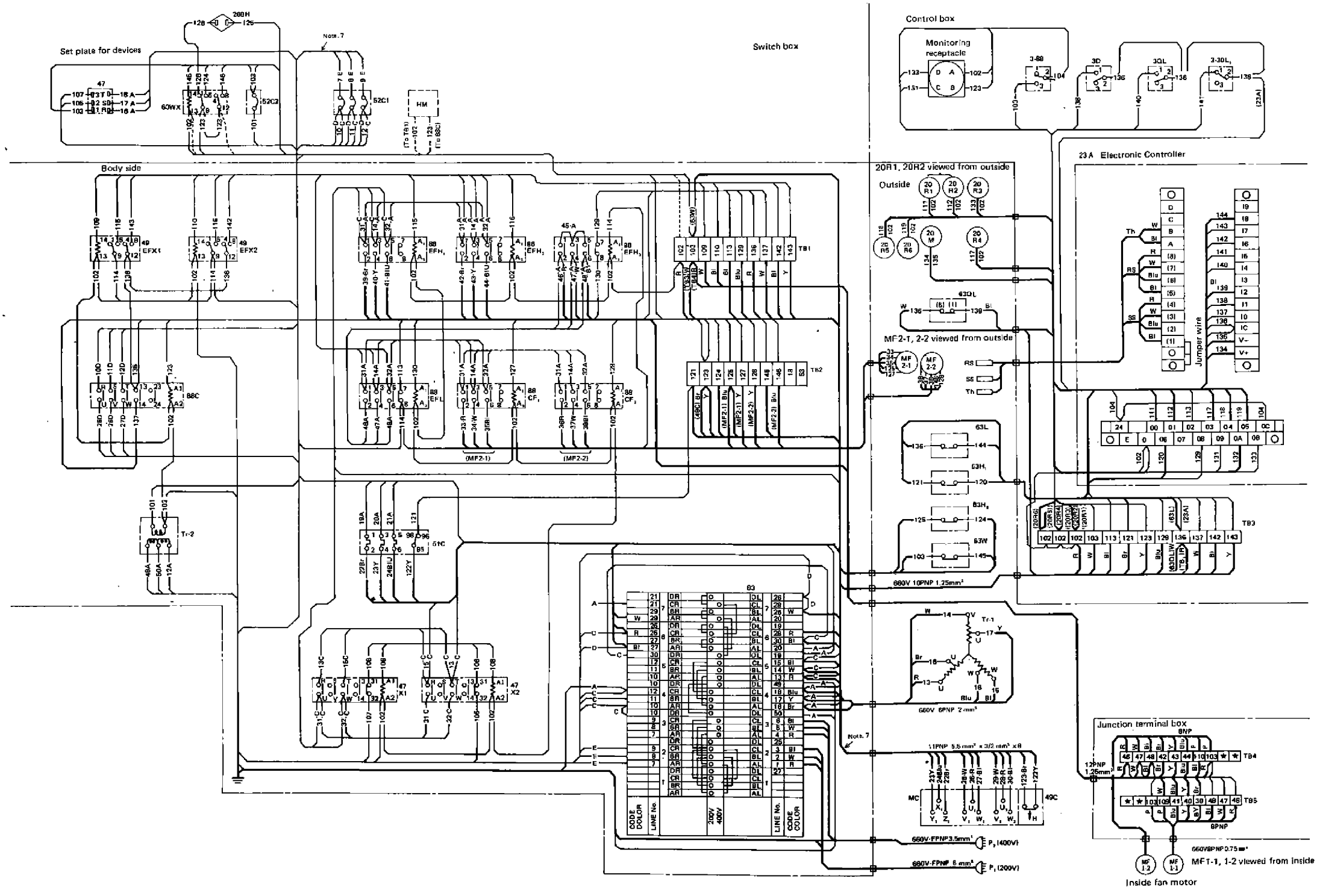

- Notes:
- Terminal numbers of each device and wires used are as shown below.  
Line No.
 

101 ~	100V KEX	0.75mm <sup>2</sup>	—
600V SCP	1.25mm <sup>2</sup>	—	A
600V SCP	2.0mm <sup>2</sup>	—	B
600V SCP	3.5mm <sup>2</sup>	—	C
600V SCP	5.5mm <sup>2</sup>	—	D
600V SCP	0.75mm <sup>2</sup>	—	—
  - Colors of wiring  
 Bl: Black Blu: Blue Br: Brown R: Red  
 Y: Yellow W: White (G): Green (for earth)
  - shows the wiring in the board.
  - shows the wiring for external devices and relay cables.
  - ..... shows the optional parts.



② LXE8-A

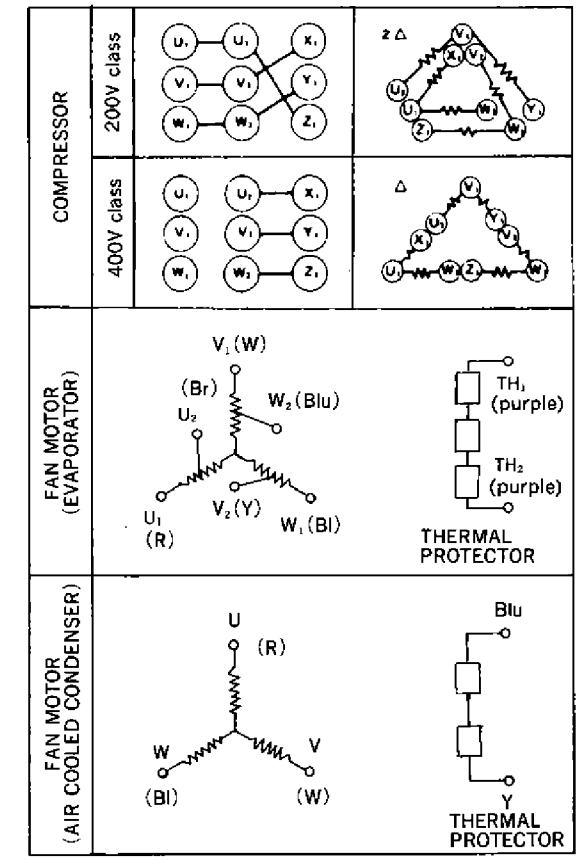
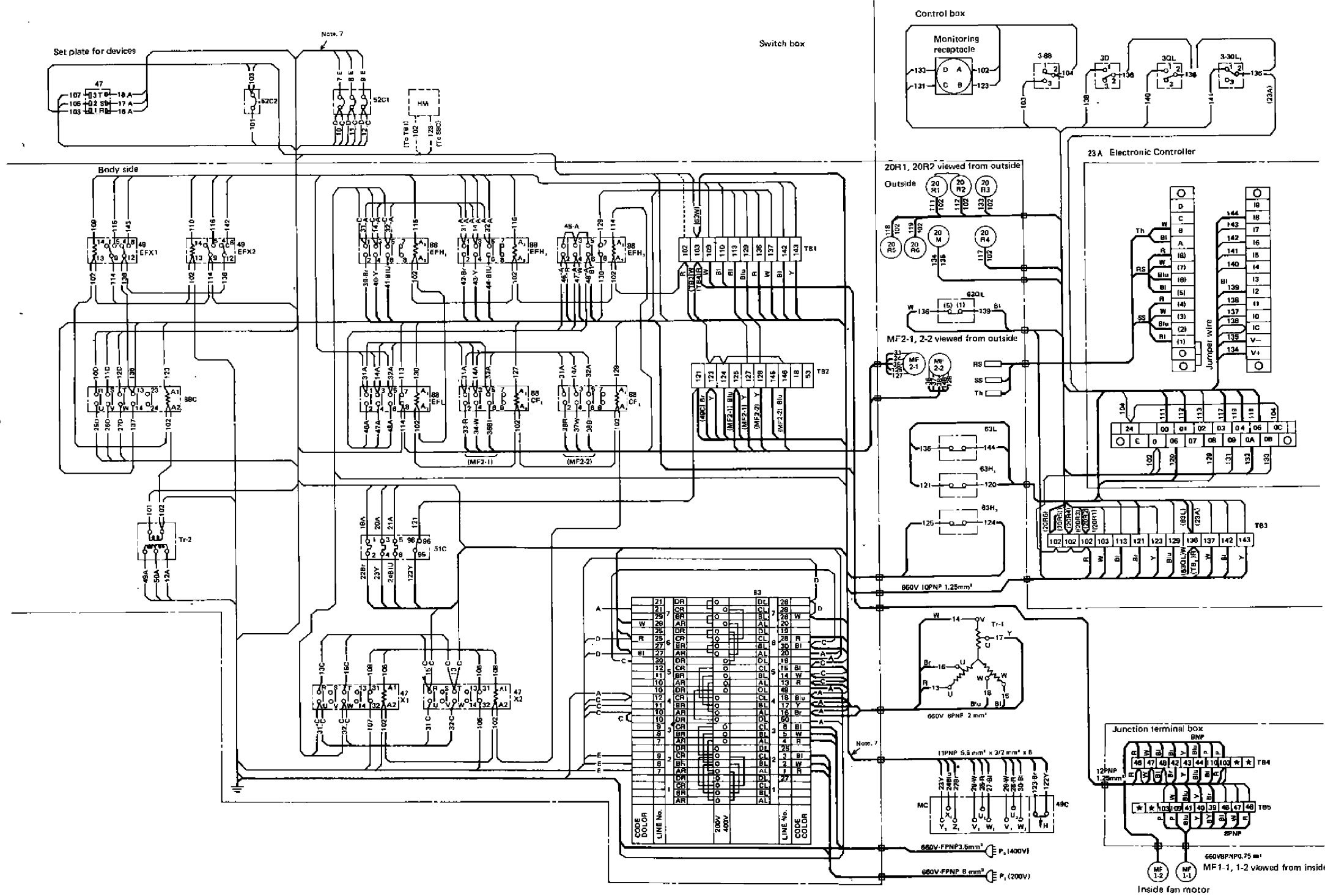

- Notes:
- Terminal numbers of each device and wires used are as shown below.  
Line No.
 

101 ~	100V KEX	0.75mm <sup>2</sup>	—
	600V SCP	1.25mm <sup>2</sup>	—A—
	600V SCP	2.0mm <sup>2</sup>	—B—
	600V SCP	3.5mm <sup>2</sup>	—C—
	600V SCP	5.5mm <sup>2</sup>	—D—
	600V SCP	0.75mm <sup>2</sup>	—
  - Colors of wiring  
Bl: Black Blu: Blue Br: Brown R: Red  
Y: Yellow W: White (G): Green (for earth)
  - shows the wiring in the board.
  - shows the wiring for external devices and relay cables.
  - ..... shows the optional parts.

**1.5 Set values of functional parts and protective devices**

Parts Name		Mark	Function	Set Value		
Pressure switch	Oil pressure protection switch WNS-C106Q	63QL	OFF ON	1.0kg/cm <sup>2</sup> 0.5kg/cm <sup>2</sup>		
	High pressure switch 20PS-K200	63H1	OFF ON	20kg/cm <sup>2</sup> 16.5kg/cm <sup>2</sup>		
	High pressure control switch ACB-BA26	63H2	OFF ON	7kg/cm <sup>2</sup> 11kg/cm <sup>2</sup>		
	Low pressure switch 20PS-K100	63L	OFF ON	40cmHgV 0.2kg/cm <sup>2</sup>		
	Water pressure switch LCB-BB07 (Ari/water cooled type)	63W	OFF ON	1kg/cm <sup>2</sup> 0.4kg/cm <sup>2</sup>		
Electronic controller	Operation mode selector	Chilled Partial frozen Frozen	ON	+25.0~-2.9°C(+77~+2.7°F)	Set point temperature	
				-3.0~-10.0°C(+26.6~+14°F)		
				-10.1~-25.0°C(+14~-13°F)		
	Delay timer	Fan	Chang over for H→L	ON	10 seconds	
			After defrosting		60 seconds	
		Compressor	Starting		3 seconds	
	Defrost timer	Initiation	Short	ON	4 hours	
			Long		12 hours	
		Compressor off			20 seconds	
		Back-up			90 minutes	
	In range mask		90 minutes			
	Fan speed selector thermostat (Chilled • partial frozen operation mode)			L→H H→L	15°C (59°F) 20°C (68°F)	chilled partial frozen
Defrost termination thermostat			OFF(Termination temperature) ON(Reset temperature)	35°C (95°F) 20°C (68°F)	supply air temperature Return air temperature Suction gas temperature	
Three way equalizing valve change-over thermostat			OFF ON OFF	Above10°C (50°F) +9.9~-10°C(+50~+14°F) Below-10.1°C(+13.8°F)	Set point temperature	
Switch box thermostat CS-7		26BH	OFF ON	35°C (95°F) 50°C (122°F)		
Breaker OC	Over-current relay GT-20-NP2S4	51C	OFF	10A		
	Circuit breaker (Main circuit) MK53	52C1	OFF	50A		
	Circuit breaker (Control circuit) CP31/7-Z	52C2	OFF	7A		
Motor	Condenser fan motor protective thermostat	49CF	OFF	125°C (257°F)		
	Evaporator fan motor protective thermostat	49EF	OFF	130°C (266°F)		
	Compressor protective thermostat	49C	OFF	105°C (221°F)		

### 1.6 Operation pressure and running current

Inside temperature 0°C (32°F) Power supply 200V, 60Hz  
Air cooled capacity controlled period

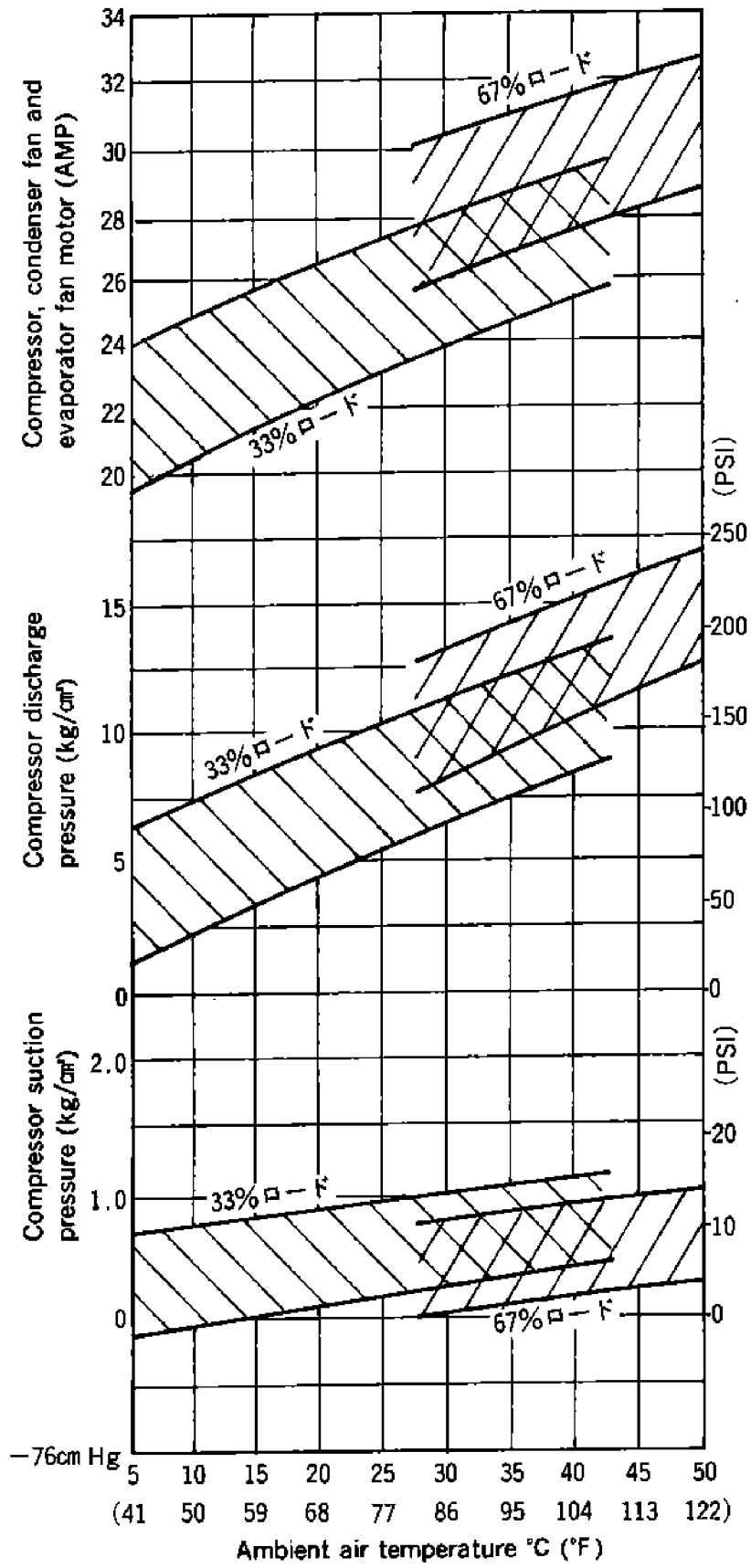

Inside temperature -18°C (-0.4°F) Air cooled operation

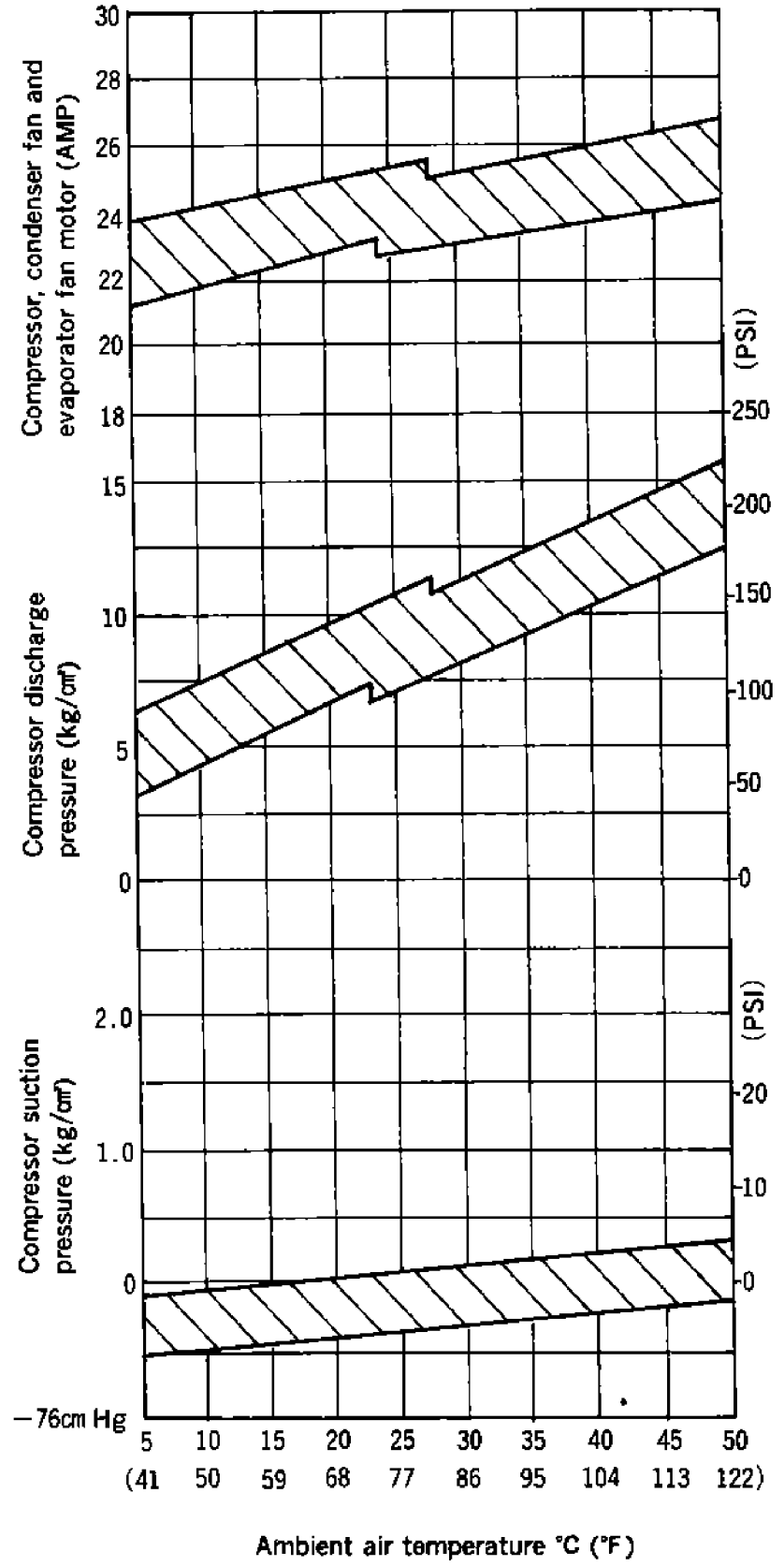

Note. Compressor unloading steps are selected automatically depending on heat load.

<For reference>

	Item	Unit	Value
1	Condenser fan motor Running current (for 2 pcs.)	A	1.5 (AC400V)
2	Evaporator fan motor Running current (for 2 pcs.)	A	High speed 3.2 (AC400V) Low speed 0.9 (AC400V)
3	Tightening torque of bolts	Compressor	435/36
		Compressor stop valve flange	255/21
		Fan motor	125/10
		Solenoid valve	55/4.3
		Expansion valve	250/20.5
		Fan	55/4.3

Note : Allowable range of tightening torque ±10%

## 2. Operation modes and circuits

### 2.1 How to read wiring diagram

(1) In the wiring diagram, marks and numbers have the meanings given below.

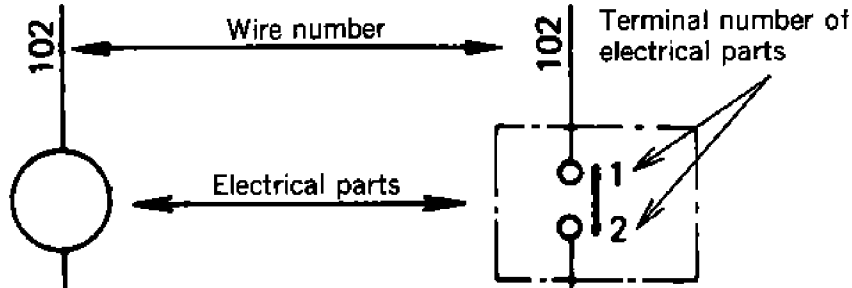

(2) Operation of contacts

- The wiring diagram indicates the stationary state in which the circuits are not activated.
- when a coil is energized (supplied with power), the associated contact changes its position.

a-contact (normal open contact)	<p>Contact is OFF when coil is not energized</p>
	<p>Contact is ON when coil is energized</p>
	<p>Contact is ON when coil is not energized</p>
	<p>Contact is OFF when coil is energized</p>

### c. Kinds of contacts

<p>a-contact</p>	<p>Operated by electromagnetic force, temperature, or pressure. ("X" denotes the reset button.)</p>
<p>b-contact</p>	
<p>Time-limit a-contact</p>	<p>Operates when the timer counting has completed.</p>
<p>3D Manual contact</p>	<p>Contact of a snap switch. This turns on as long as the switch is kept pressed and turns off immediately when released.</p>
<p>3-88 3-30L Manual contact</p>	<p>Contact of a snap switch. This turns on and holds the on state once the switch is turned on.</p>
<p>Voltage selector contact (except 3-88, 3-30L)</p>	<p>This turns on when the selector is set to 200V class</p> <p>200V class</p>
	<p>This turns on when the selector is set to 400V class</p> <p>400V class</p>

d. How to read the wiring diagram of the voltage selector switch.

In the chart, "●" denotes that the contact is on.  
The following example shows the states between terminals AL2 and AR2, and between AL3 and AR2.

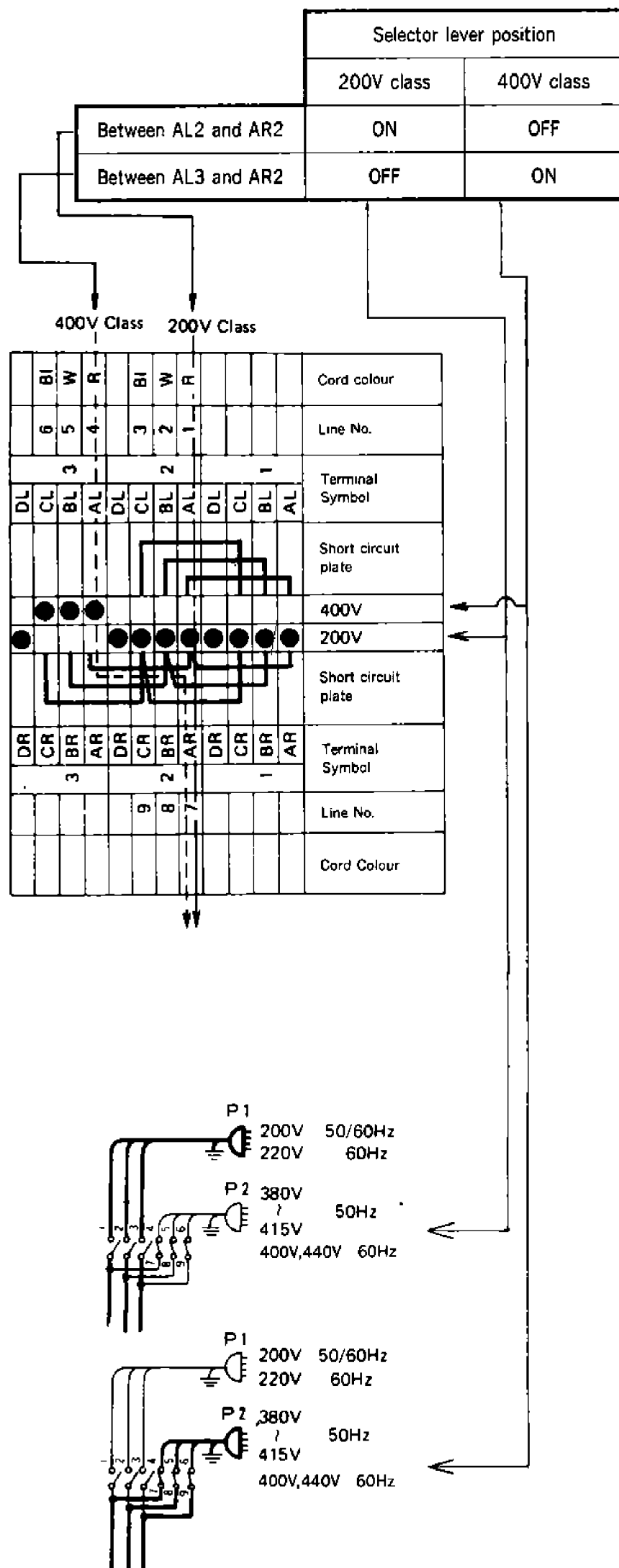

## 2.2 High pressure control

When ambient temperature drops during air cooled operation, condensing pressure (high pressure) drops accordingly.

In addition, low pressure drops in accordance with condensing pressure drop and cooling capacity reduces.

In order to prevent high pressure from dropping, the high pressure control pressure switch (63H2) is installed to turn off the magnetic switch (88CF1) for condenser fan when high pressure drops lower than 7 kg/cm<sup>2</sup>. So one of the condenser fan (MF2-1) stops automatically, which prevents high pressure from dropping.

## 2.3 Air cooled and water cooled operation (Air/water cooled type)

The unit is possible to operate on either operations of air cooled or water cooled.

During the transit on the land, in the yard or on the deck, the air cooled operation is normal, and the operation in ship holds is normally water cooled. The operation can be changed from air cooled to water cooled and vice versa automatically by the water pressure switch; i.e. when water pressure at the inlet of the water cooled condenser rises higher than the presetting value, the contact points of the water pressure switch are cut out, so the condenser fan motors stop, and the water cooled operation starts. On the contrary, when water supply is suspended during the water cooled operation, the contact points of the water pressure switch come in contact and the condenser fan motors rotate. Thus, the air cooled operation starts.

### Note :

Note that the condenser fan on the left may sometimes operate to cool the control box during water cooled operation.

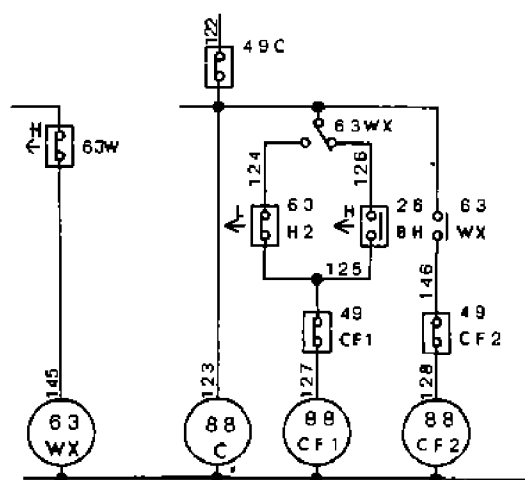

### 2.4 Voltage selection system (Change-over for 200V/400V class)

(1) The dual rating system is adopted to the compressor motor and the transformer method to the fan motor of the units. Turn the lever of the voltage selector switch (multi-contact cam switch) manually in accordance with the power supply available to change the wiring of the transformers of each motor and the control circuit suited for respective power supply. The internal wiring of the dual rating system in the compressor is as shown on the right.

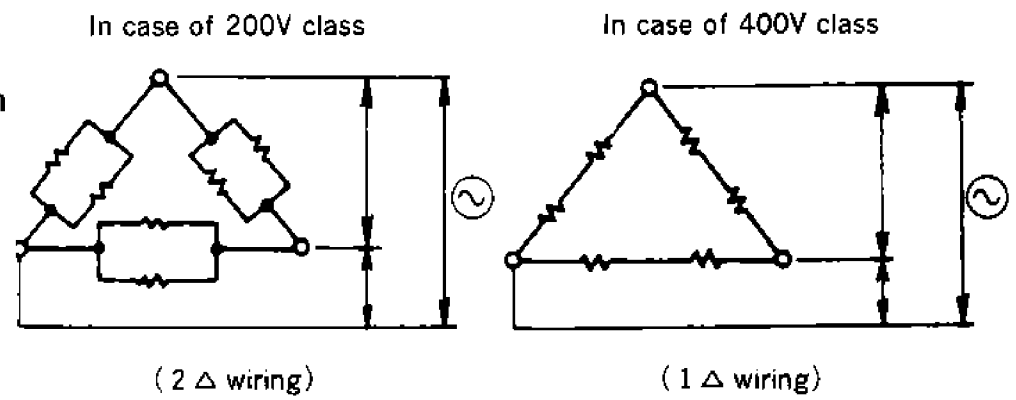

(2) Circuitry formation

○ In case of 200V class (Set the selector lever to "200V Class".)

The contacts (except 3-88 and 3-30L) shown by  have continuity on the sequence diagram.

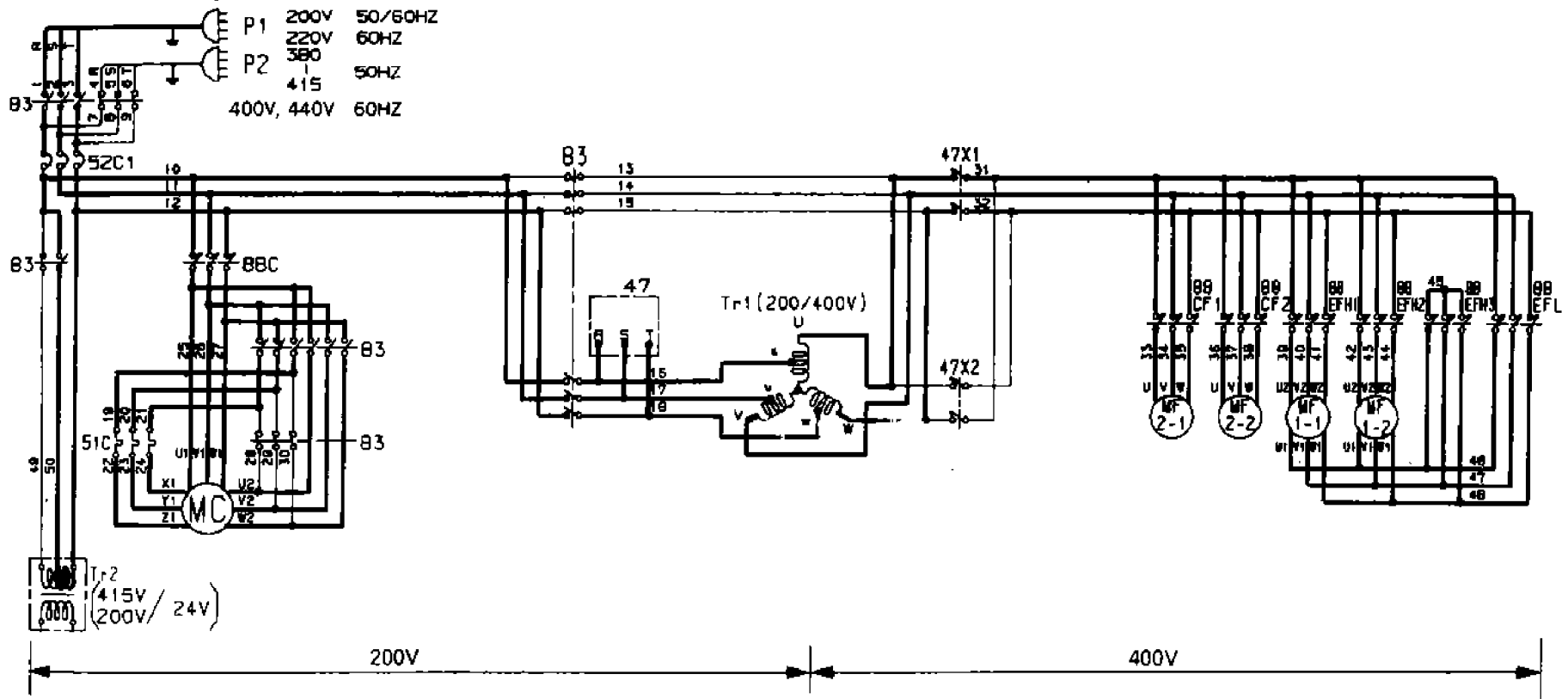

○ In case of 400V Class (set the selector lever to "400V Class".)

The contacts shown by  have continuity on the sequence diagram and form the 400V class circuit.

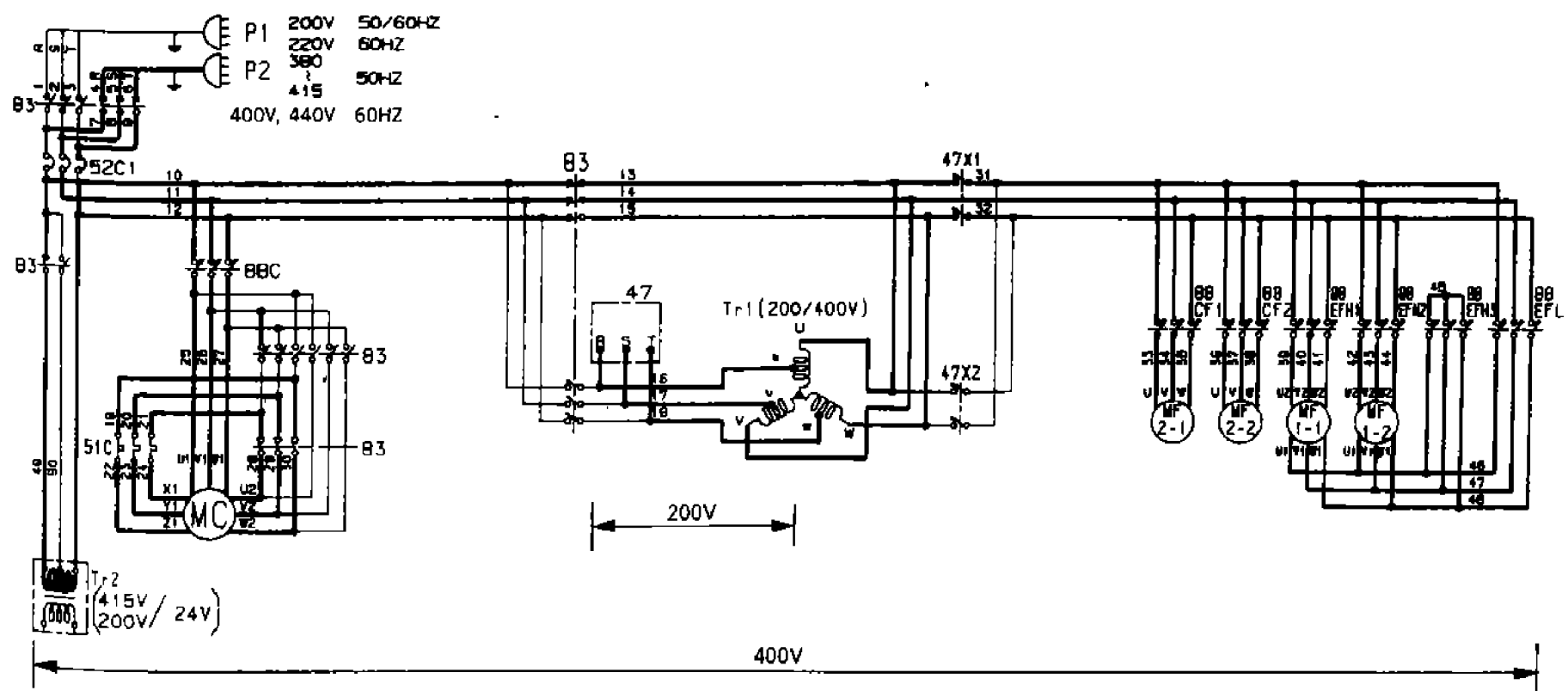



(3) Phase selection

The reversible method is adopted to the compressor and the proper phase selection method to the fan motor of the units.

○ Compressor

The hydraulic pump adopted is a reversible trochoid pump, so the predesigned oil pressure can be obtained regardless of turning direction of the built-in motor.

○ Fan motor

The phase sequence controller adopted exchanges R phase with T phase automatically in case of wrong phase.

47: phase sequence controller

47X1•2: Magnetic switches for phase change-over

● Proper phase

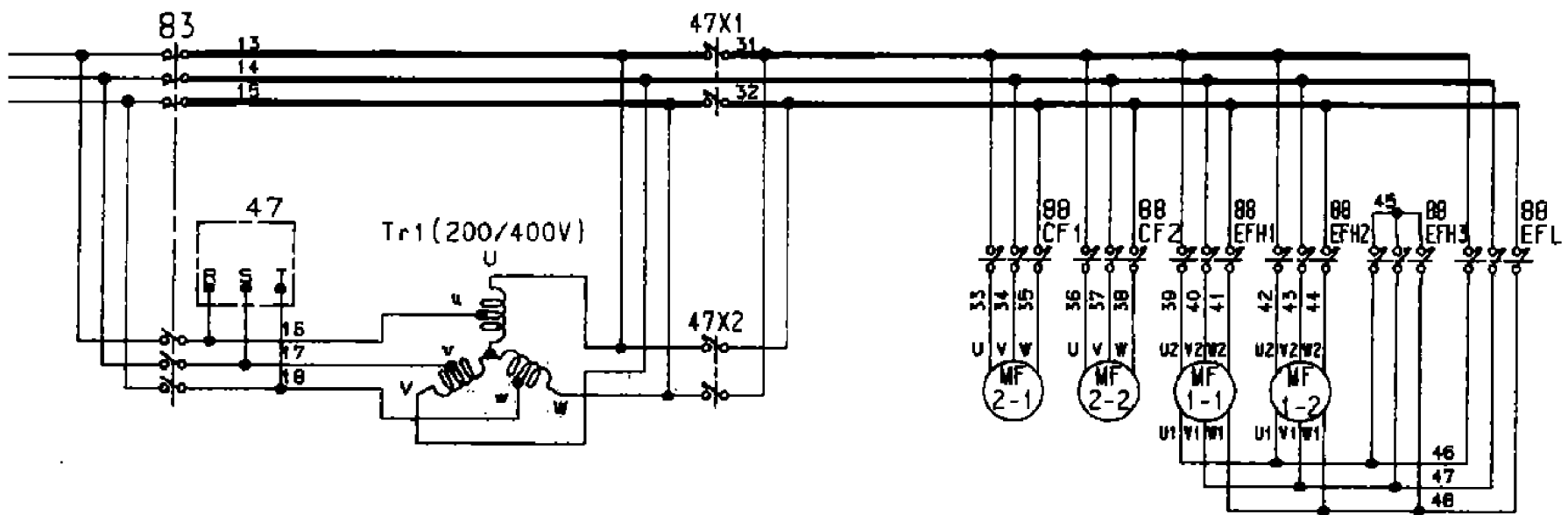

● Wrong phase

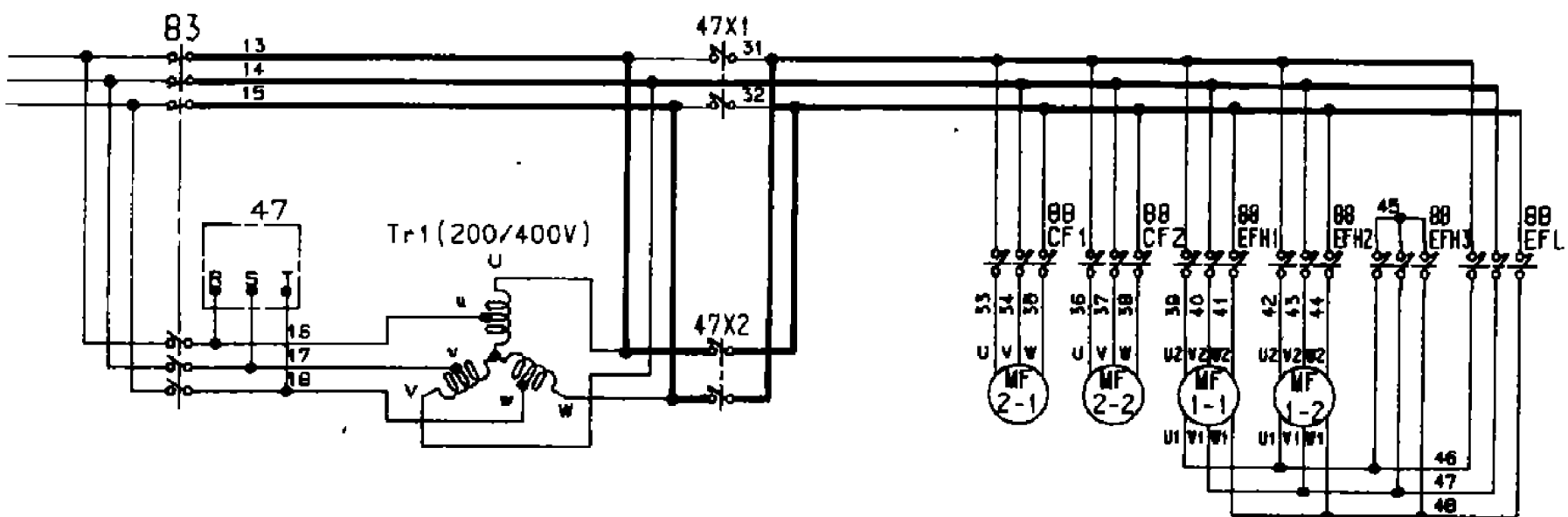

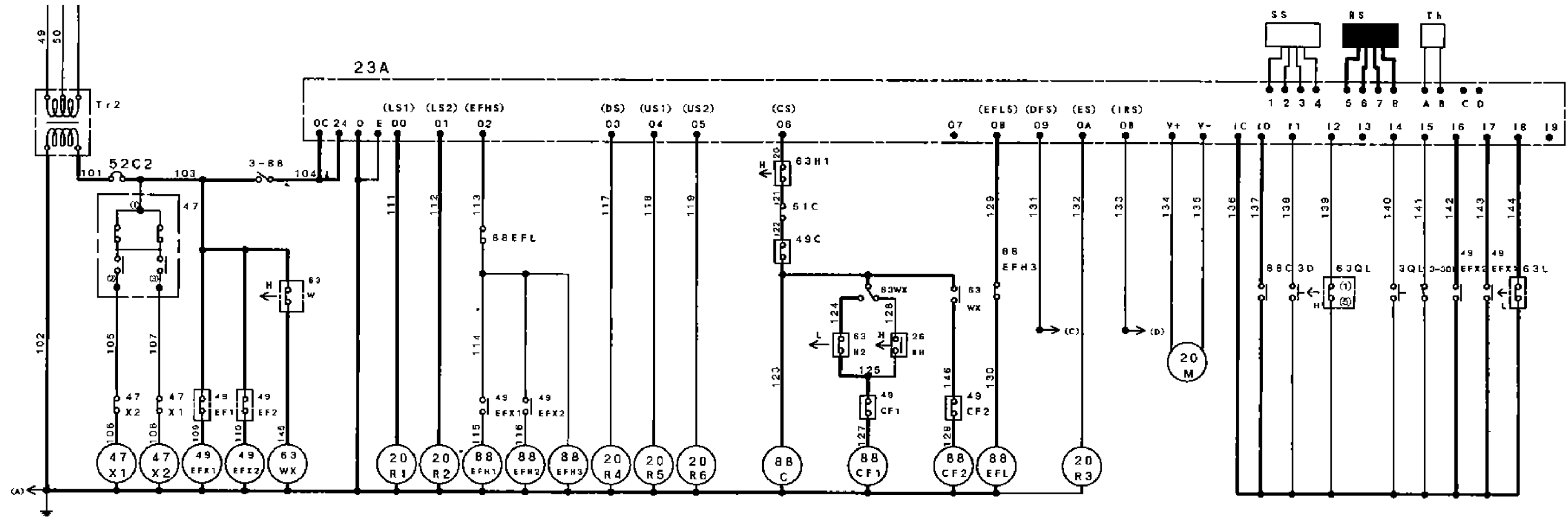

30

- (1) Selection of operation modes is performed automatically by setting of the electronic controller.  
Frozen operation: below  $-10.1^{\circ}\text{C}$  ( $+13.8^{\circ}\text{F}$ ), return air temperature control
- (2) After a lapse of 5 seconds from the operation switch (3-88) is turned on,
  - (a) LED lamp lights up.
  - (b) Liquid solenoid valves (20R1 and 20R2) will be open and the evaporator fans will run in low speed.
  - (c) The compressor will start after a lapse of further 3 seconds by the function of the delay timer.

- (3) The compressor is operated on and off, sensing return air temperature of the evaporator to control frozen temperature, and at the same time open or close the main liquid solenoid valve (20R1) (expansion valve side).  
Compressor OFF: Preset temperature (Ⓐ point)  
Compressor ON: Preset temperature  $+1.0^{\circ}\text{C}$  ( $+1.8^{\circ}\text{F}$ ) (Ⓒ point)  
When the compressor operates,  
The pilot lamp for compressor operation (Green) lights up.  
The evaporator fans operate.  
The main liquid solenoid valve (expansion valve side) (20R1) opens.
- (4) When return air temperature in the storage drops to the preset temperature, the in range lamp (Orange) lights up.

	Upper limit	Lower limit
ON (Ⓒ point)	$+1.0^{\circ}\text{C}$ ( $+1.8^{\circ}\text{F}$ )	$-1.0^{\circ}\text{C}$ ( $-1.8^{\circ}\text{F}$ )
OFF (Ⓐ point)	$+2.0^{\circ}\text{C}$ ( $+3.6^{\circ}\text{F}$ )	$-2.0^{\circ}\text{C}$ ( $-3.6^{\circ}\text{F}$ )

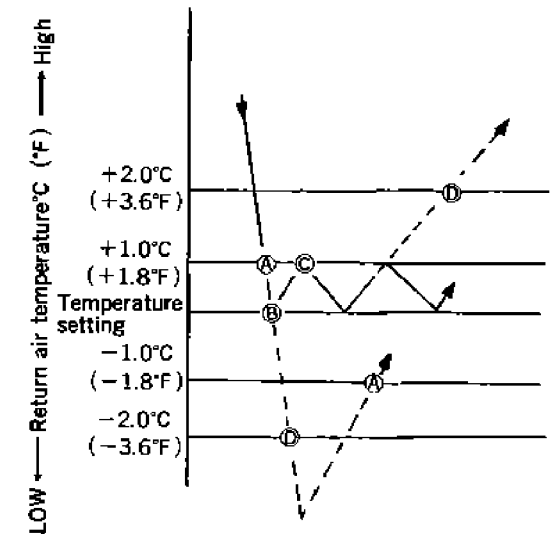

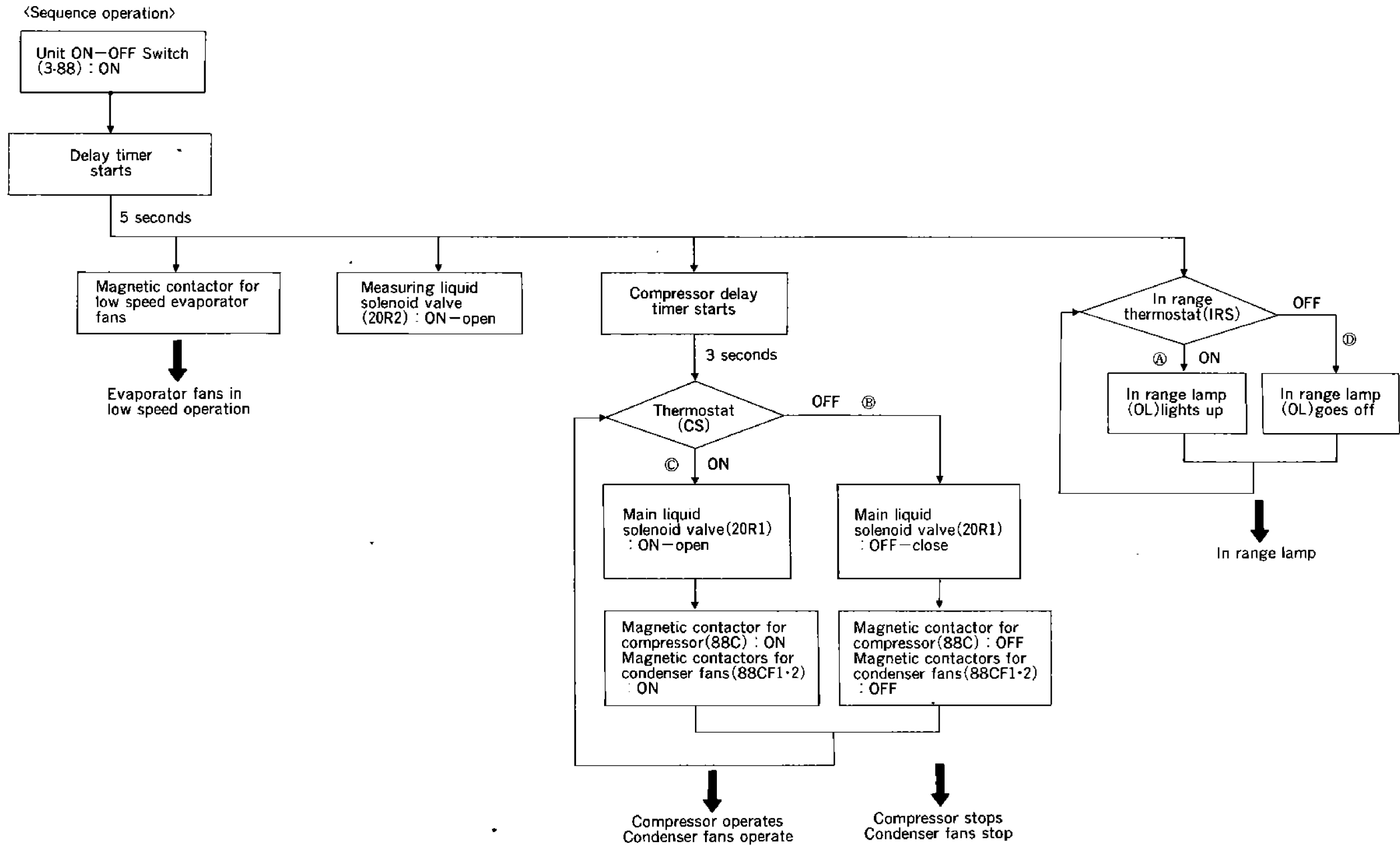

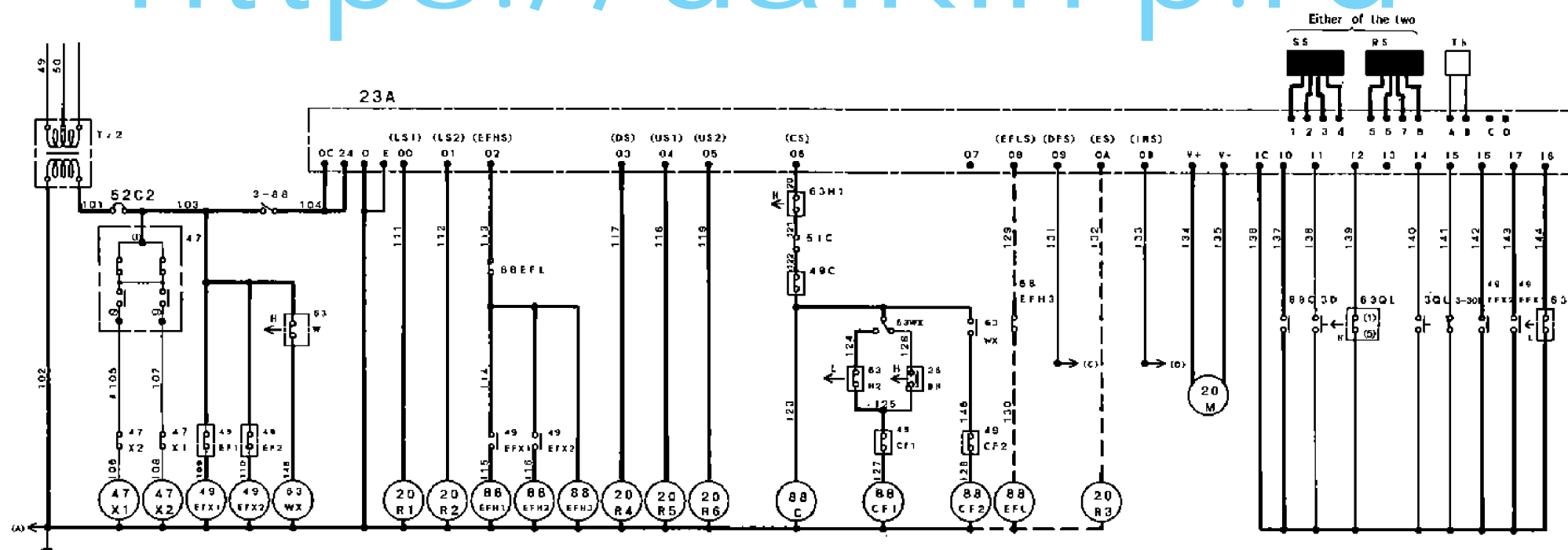

- (1) When temperature setting is over  $-2.9^{\circ}\text{C}$  ( $+26.8^{\circ}\text{F}$ ), chilled operation is performed, and when it is within  $-3.0\sim -10.0^{\circ}\text{C}$  ( $+26.6\sim +14^{\circ}\text{F}$ ), partial frozen operation is performed. 23A forms chilled or partial frozen operation circuit automatically.
- (2) Chilled or partial frozen operation is controlled, sensing supply air temperature or return air temperature of the evaporator respectively. Capacity is controlled by controlling hot gas bypass amount with modulating valve (20M) continuously and at the same time controlling the expansion valve with the 3 way equalizing valve (20R3) (when temperature setting is lower or equal to  $9.9^{\circ}\text{C}$  ( $49.8^{\circ}\text{F}$ )). In addition, the evaporator fan speed can be changed from high to low and vice versa by the electronic controller.

During chilled operation mode:

- Supply air temperature is higher than  $20^{\circ}\text{C}$  ( $68^{\circ}\text{F}$ ) ...  
Operation with low fan speed
- Supply air temperature is lower than  $15^{\circ}\text{C}$  ( $59^{\circ}\text{F}$ ) ...  
Operation with high fan speed

During partial frozen operation mode:

- Return air temperature is higher than  $20^{\circ}\text{C}$  ( $68^{\circ}\text{F}$ ) ...  
Operation with low fan speed
- Return air temperature is lower than  $15^{\circ}\text{C}$  ( $59^{\circ}\text{F}$ ) ...  
Operation with high fan speed

If inside temperature reaches to the above temperature during pull down, fan speed is changed automatically from low to high.

When the fan speed is changed from high to low and vice versa, it is delayed in 10 seconds to prevent back electromotive force from occurring.

- (a) The same operation procedure as that of frozen operation is performed until controlled air temperature becomes setting temperature  $+1^{\circ}\text{C}$  ( $+1.8^{\circ}\text{F}$ ) from pull-down expect that the evaporator fan speed is changed. (A point)
- (b) When controlled air temperature becomes setting temperature  $+1^{\circ}\text{C}$  ( $+1.8^{\circ}\text{F}$ ), IRS is turned on (pilot lamp for OL light up), and at the same time voltage is impressed to 20M, which opens 20M, allowing the hot gas to flow to the evaporator side. (B point). However, when power is supplied or setting temperature is changed, or return air temperature is higher than setting temperature by  $5^{\circ}\text{C}$  ( $41^{\circ}\text{F}$ ), 20M may sometimes remain closed.
- (c) When the hot gas starts flowing, controlled air temperature rises temporarily, which turns off IRS. After repeating such procedure several times, operation becomes stable (C point).
- (d) It requires a certain time (this differs more or less with setting temperature and ambient temperature) before stabilizing operation (opening degree of 20M; i. e. hot gas bypass amount becomes stable). Since controlled air temperature reaches to setting temperature during such time, operation becomes stable gradually by changing opening degree of the valve (amount of hot gas). (C point)

(3) In addition to the proportional control by hot-gas bypass, compressor unloading operation is performed during chilled and partial frozen operation.

Operation steps are available in three steps, 67%, 33% in addition to 100%, and are selected appropriately and automatically depending on heat load.

Basic operation steps are as shown right. During sensing time, however, operation steps may sometimes differ with those shown in the following table.

Compressor unloading operation		Pull-down period (Inside temp. > Temperature setting +0.5°C (+0.9°F) or higher)	During capacity-control operation (Temperature setting = 0.5°C (+0.9°F) ≥ Inside temperature ≥ Temperature setting -1.5°C (-2.7°F)	During heat-up (Inside temperature < Temperature setting -1.5°C (-2.7°F))
33%	20R5 ON 20R6 ON	×	○ or ○	×
67%	20R5 ON 20R6 OFF	×	○ or ○	×
100%	20R5 OFF 20R6 OFF	○	○	○

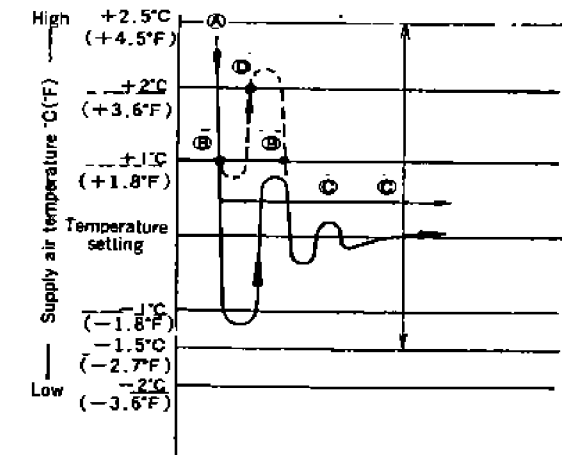

Unloading operation is not performed during frozen operation or defrosting, but full-load operation is performed.

33

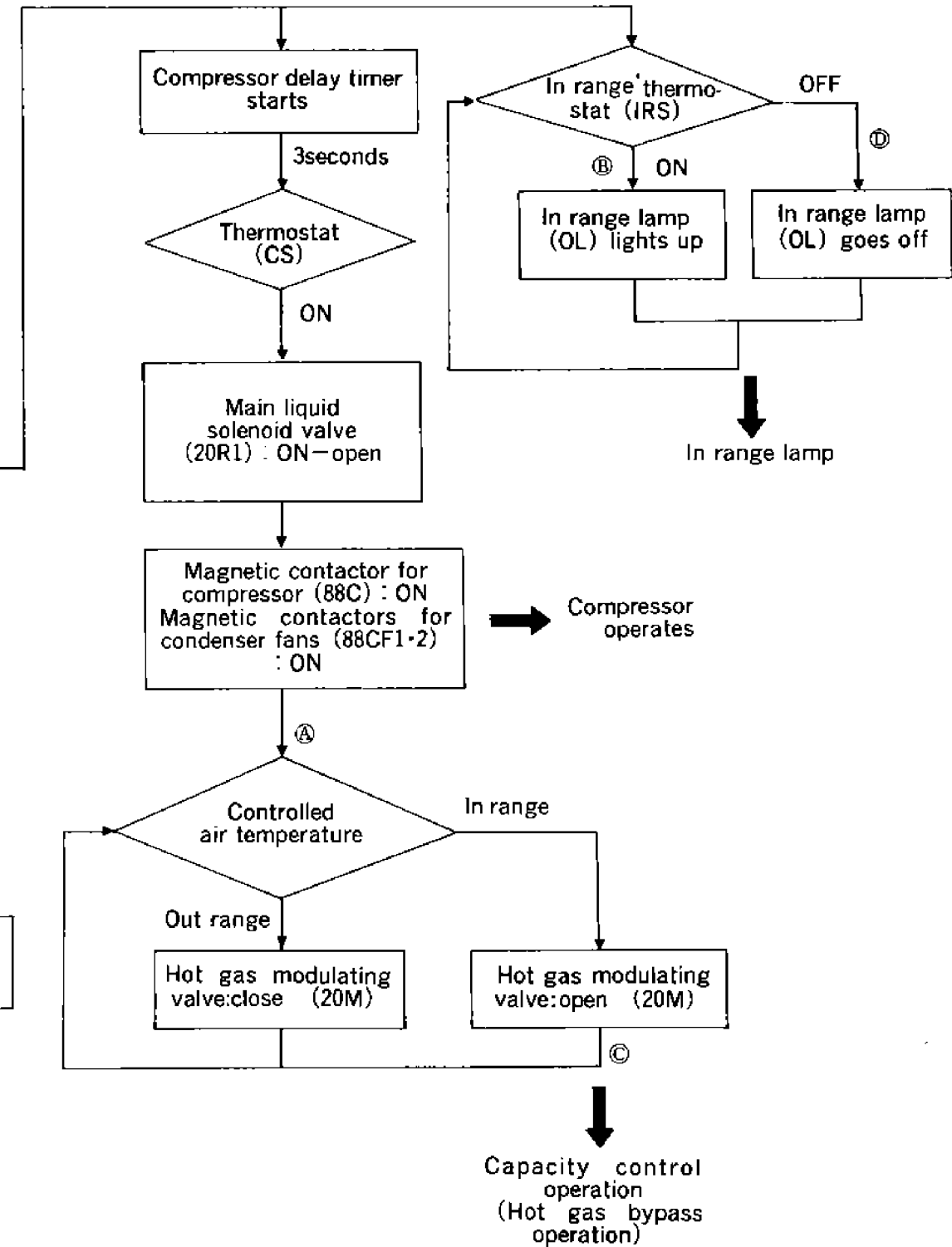
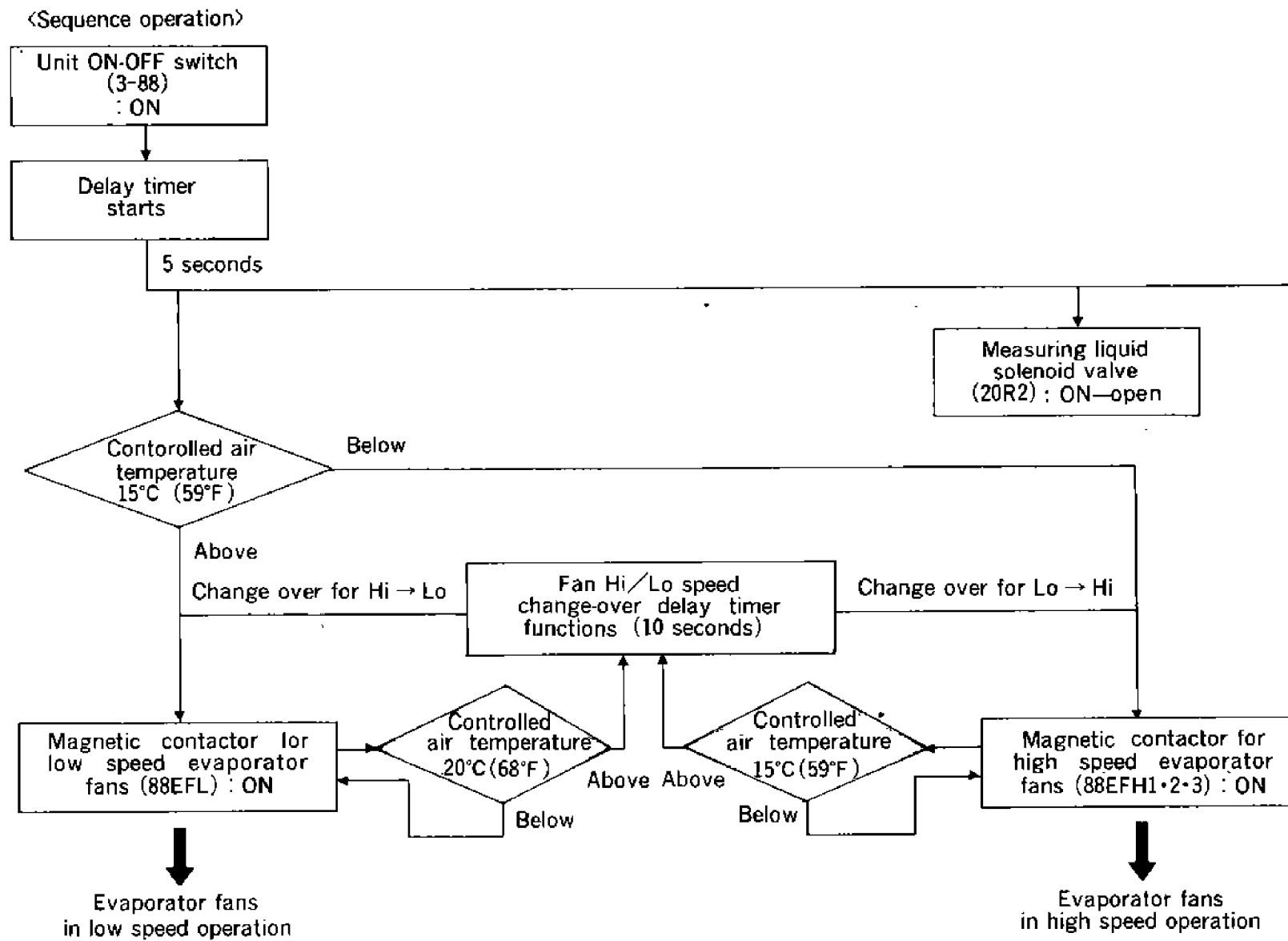

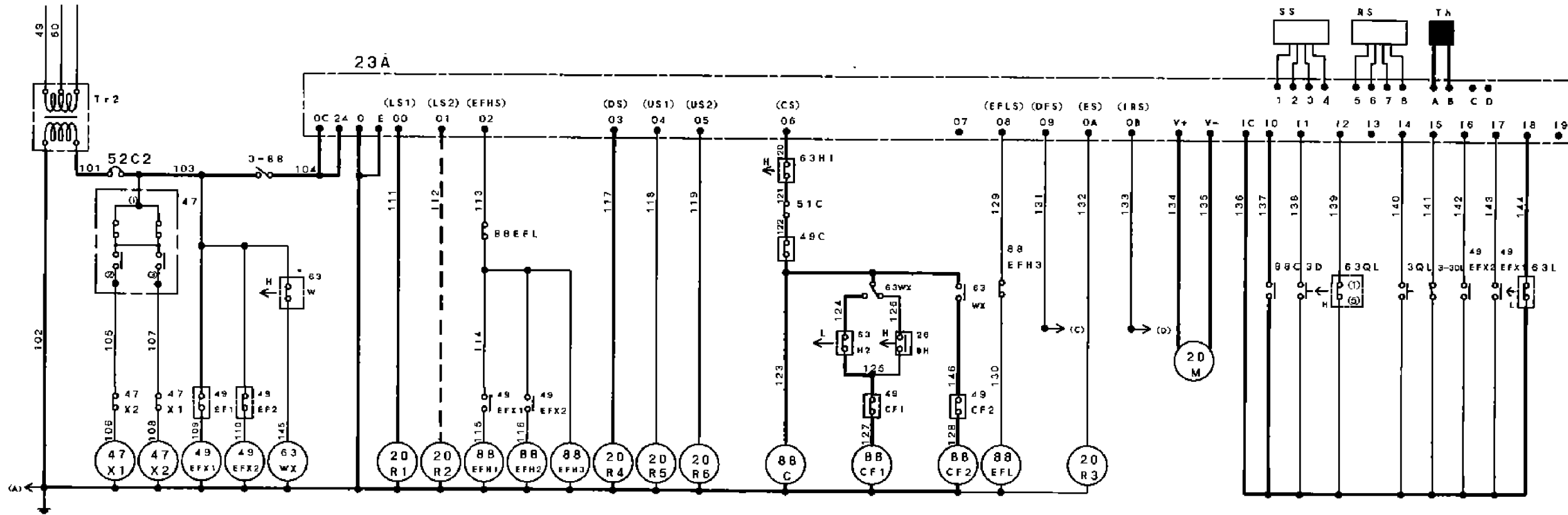

34

The hot-gas defrost system is adopted in the units; i.e. the high temperature and high pressure refrigerant (hot gas) from the compressor is sent to the evaporator and drain pan for defrosting. Since the evaporator is heated directly by the hot refrigerant in the evaporator, defrosting can be performed effectively.

(1) Defrosting starts

The dual timer method and manual switch method are adopted to start defrosting.

(a) Dual timer method

○ Short-cycle defrosting

During the time when controlled air temperature drops to in range temperature from pull down operation, defrosting starts every 4 hours by the short timer of the electronic controller (23A).

○ Long cycle defrosting

When controlled air temperature becomes within in range temperature (in range lamp lights up), defrosting starts every 12 hours by the long timer of the electronic controller (23A).

(b) Manual switch method

When the manual defrost switch (3D) is set to "MANUAL", defrosting starts.

(2) Defrost operation

The devices and components operate as shown below during defrost operation

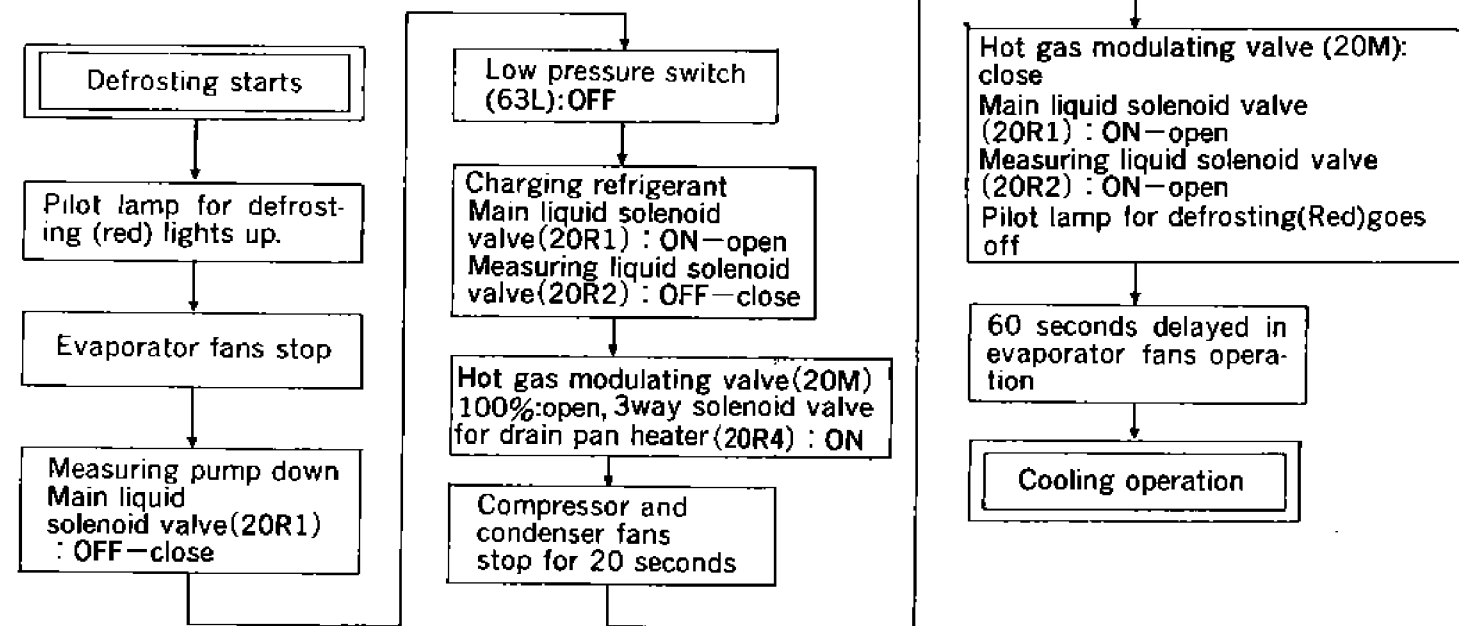

**Notes:** When suction pipe temperature is above 20°C(68°F) defrost-initiation command may sometimes not be received.

<Sequence operation>

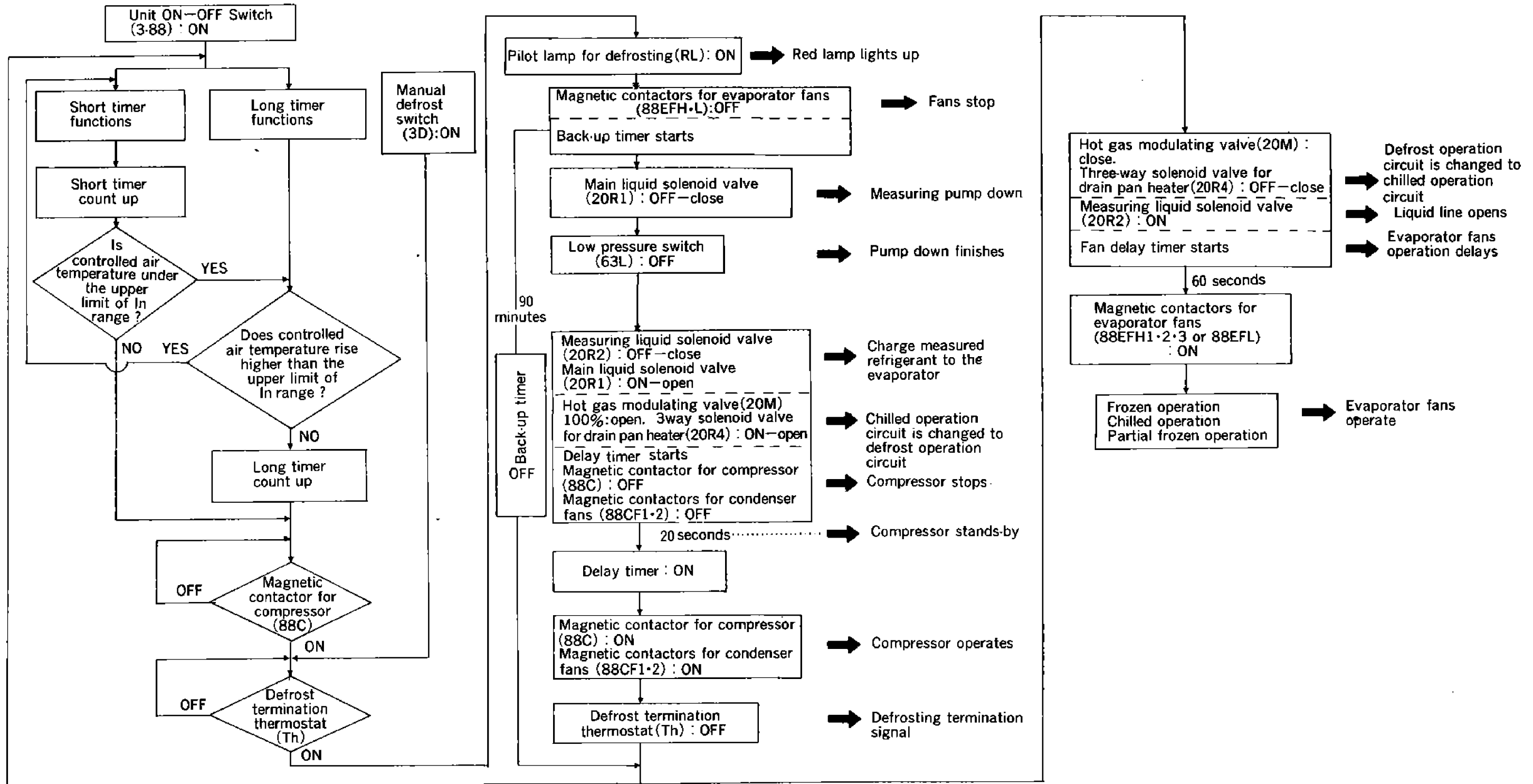



2.8 Heat-up operation

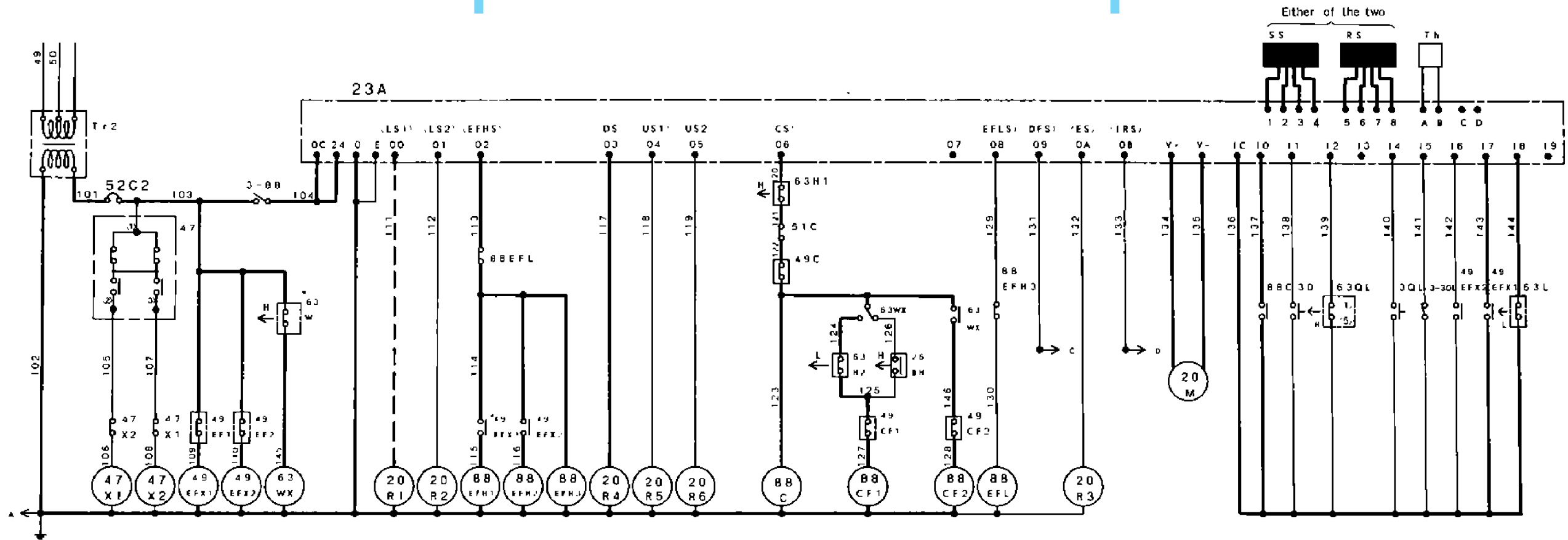

36

The hot gas heat-up system is adopted in the units; i. e. the high temperature and high pressure refrigerant (hot gas) from the compressor is sent to the evaporator to heat inside air.

- (1) Starting of heat-up  
Heat-up is performed only when the controller is set to "chilled mode" and partial frozen mode : (setting temperature above  $-10^{\circ}\text{C}$  [ $+14^{\circ}\text{F}$ ]). Heat-up begins automatically by the signal from the electronic controller (23A) when the operation switch (3-88) is turned on.
- (2) Heat-up operation  
The devices and components operate as described on the right during heat-up operation
- (3) Unloading operation is not performed during heat-up operation.

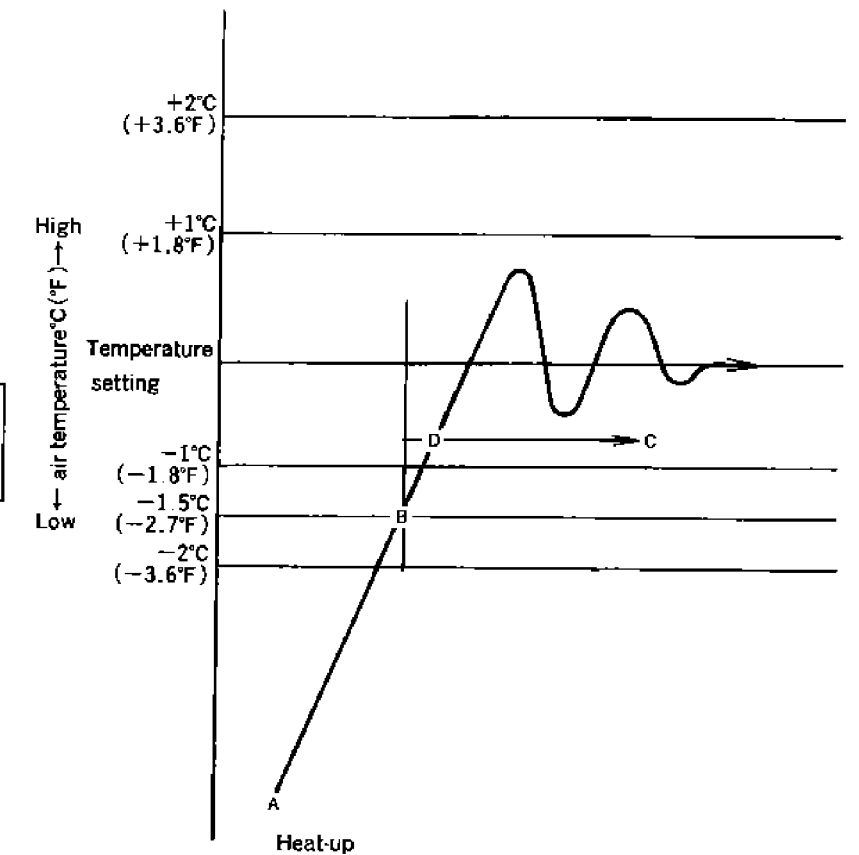
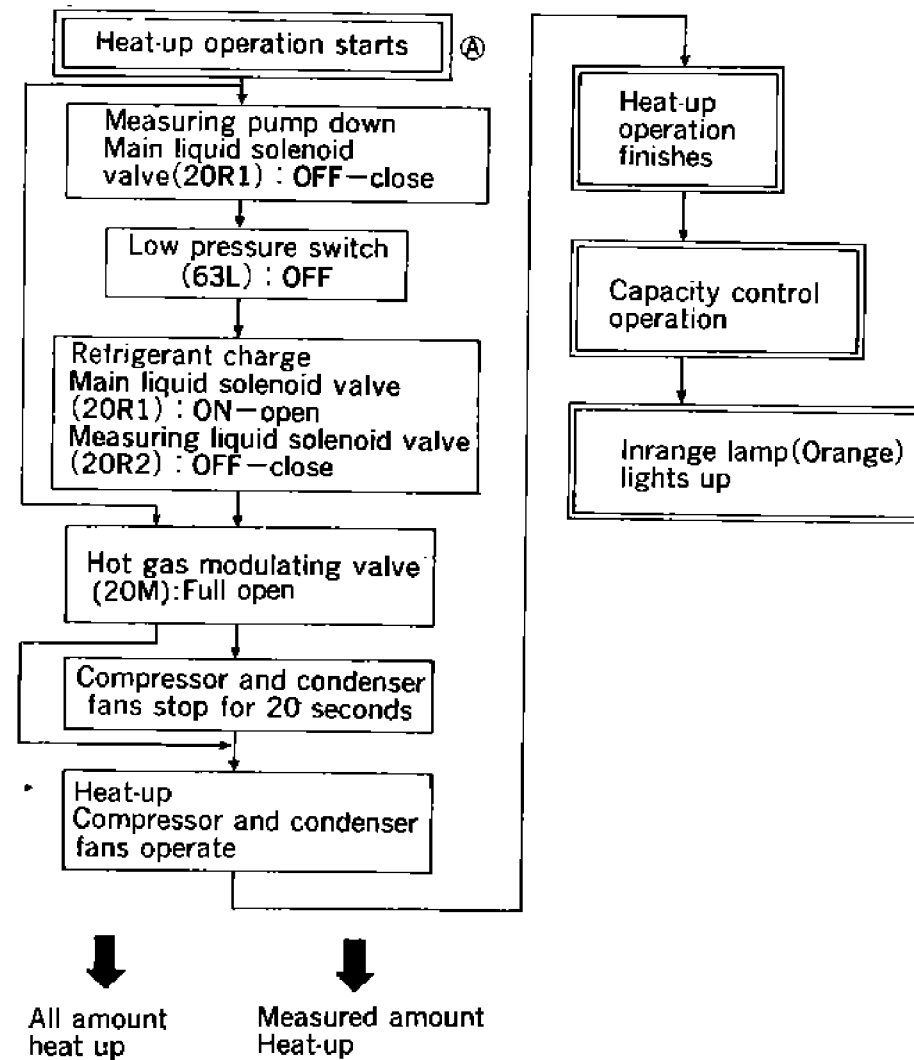

<Sequence operation>

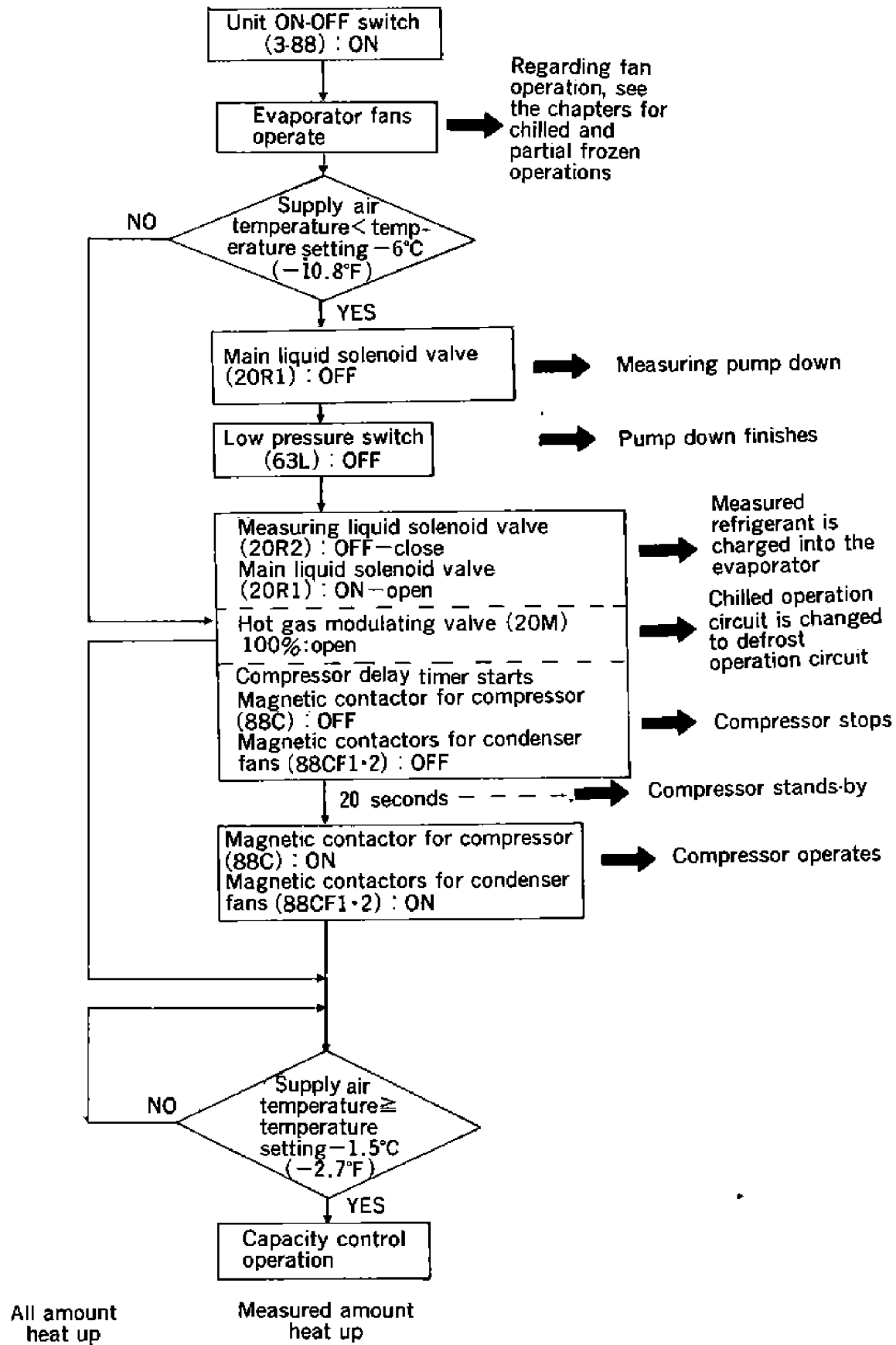

## 2.9 Refrigerant flow at each operation mode

### ●Frozen operation

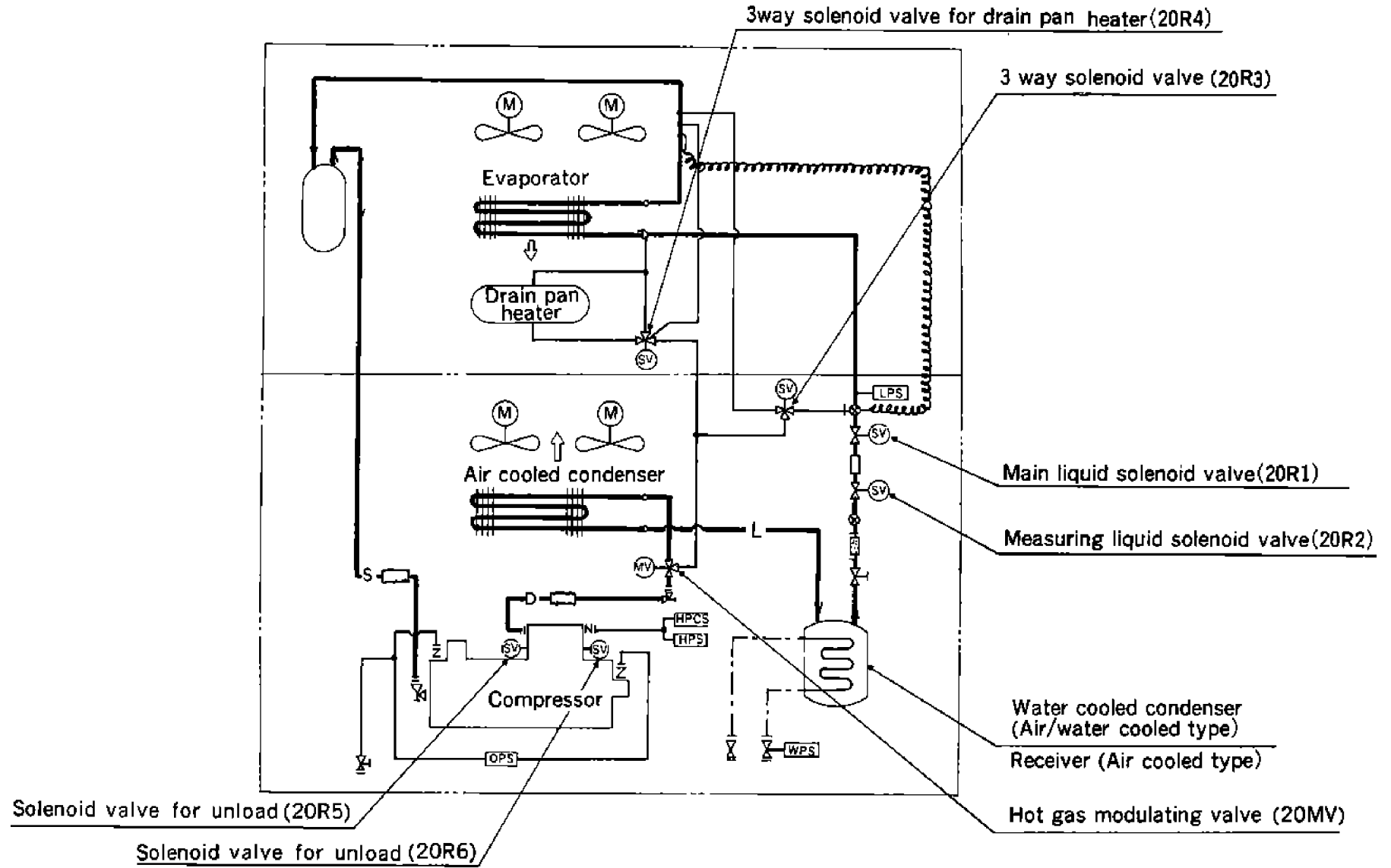

### ●Chilled • Partial frozen operation

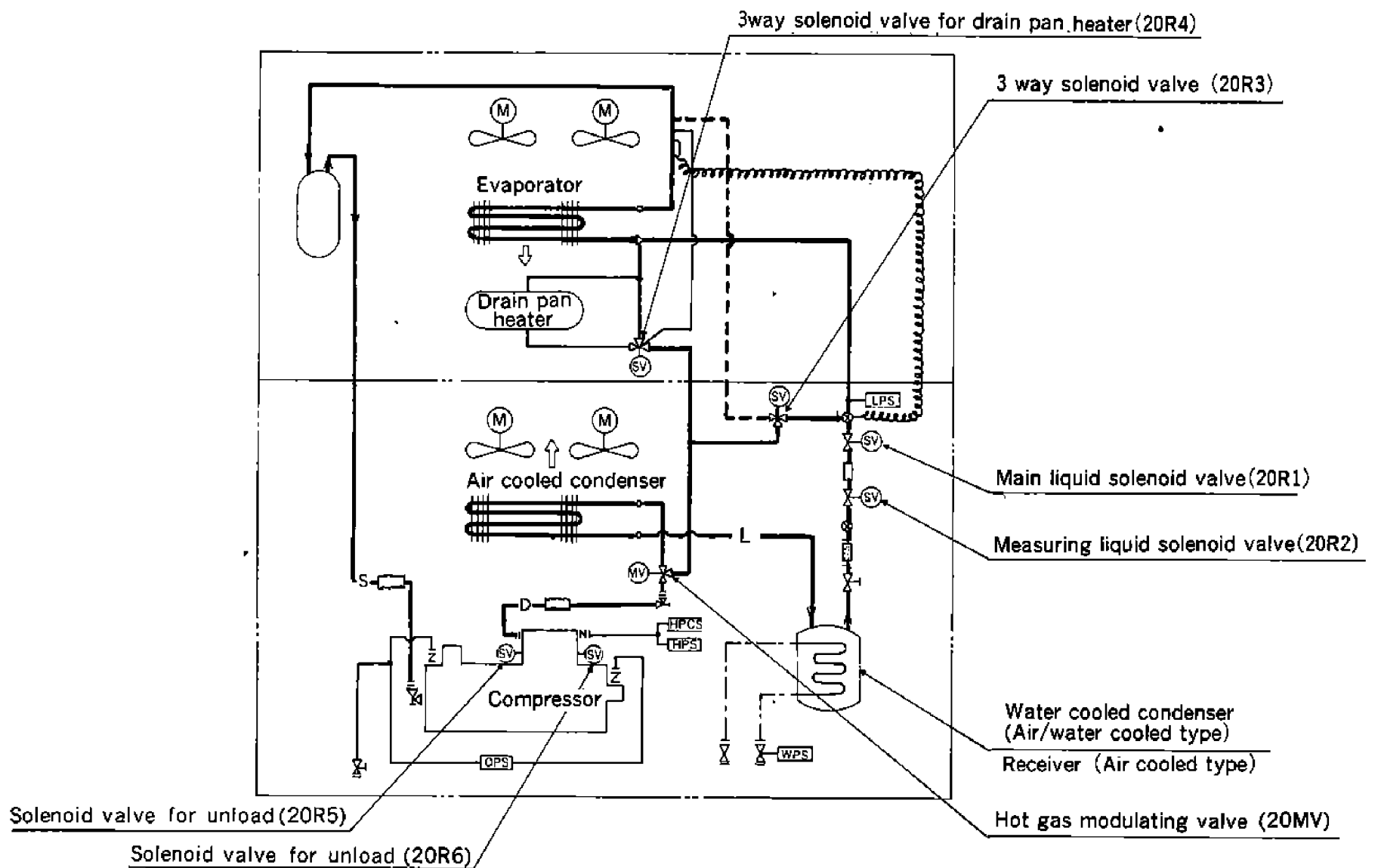

● Defrost operation

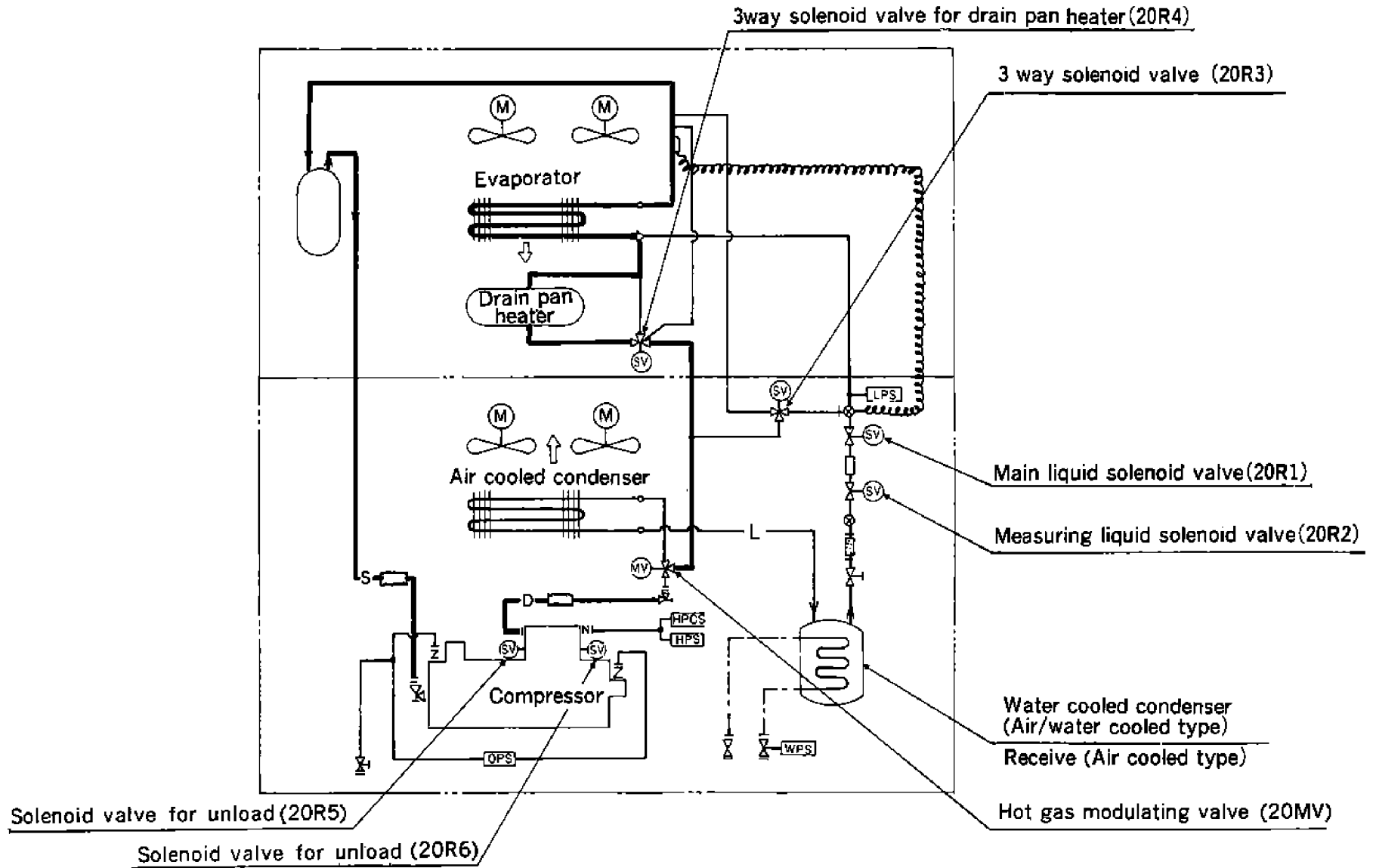

● Heat-up operation

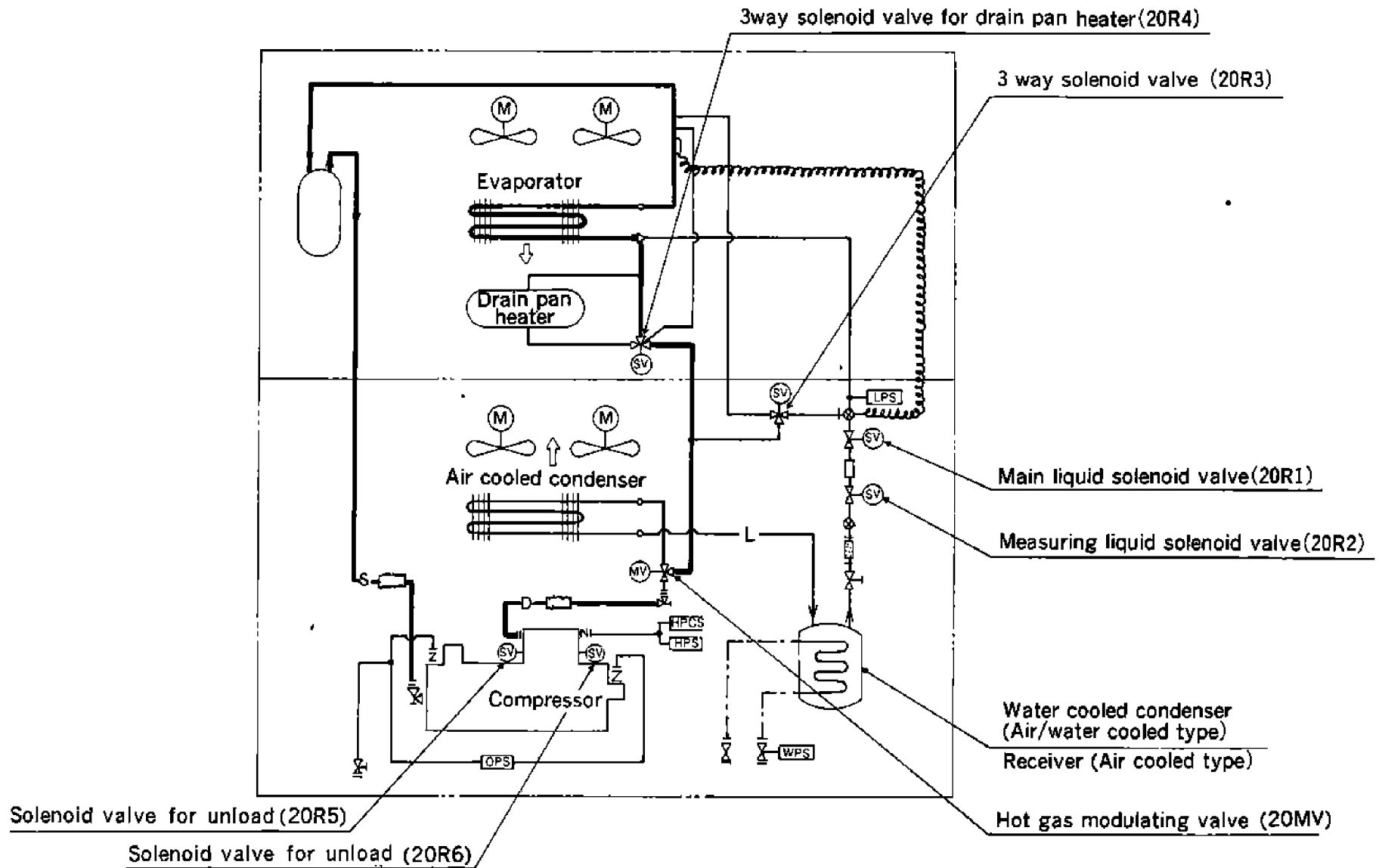

### 2.10 Pilot lamps and monitoring circuit

(1) Three lamps which indicate operating mode are mounted on the front panel of the control box.

- Red : indicates defrost mode (RL)
- Green : indicates that the compressor is running (GL)
- Orange : indicates that inside temperature is with in range (Within  $\pm 2^{\circ}\text{C}$  ( $\pm 3.6^{\circ}\text{F}$ ) of the preset temperature) (OL)

Receptacle for monitoring is fitted and its connections is shown at below.

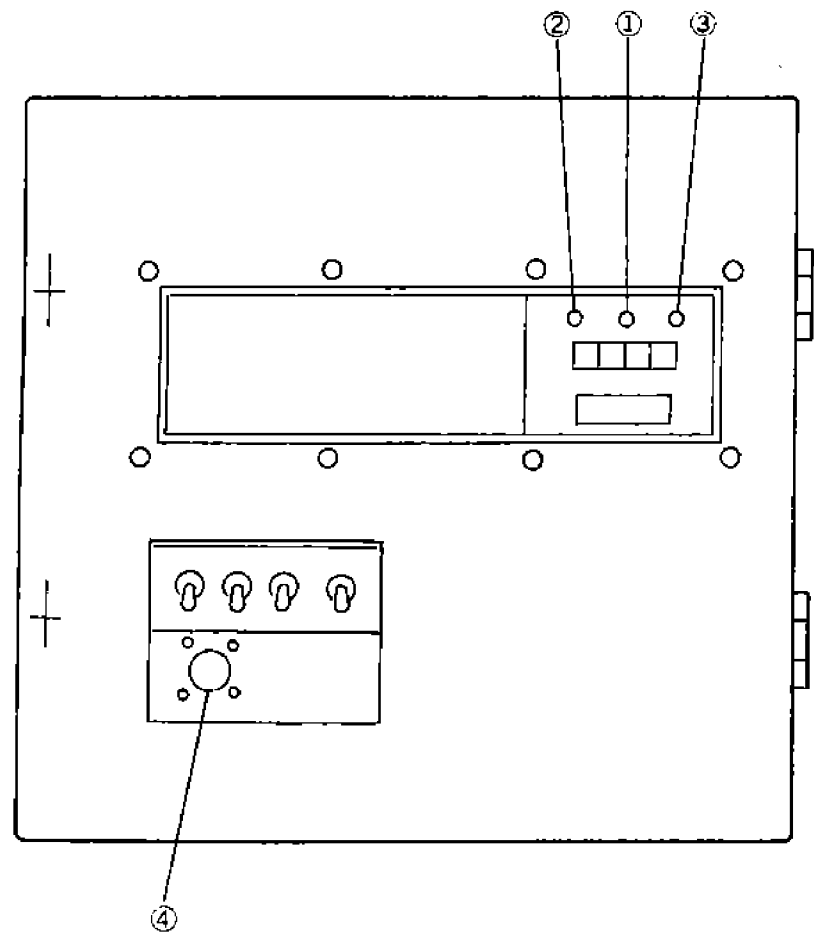
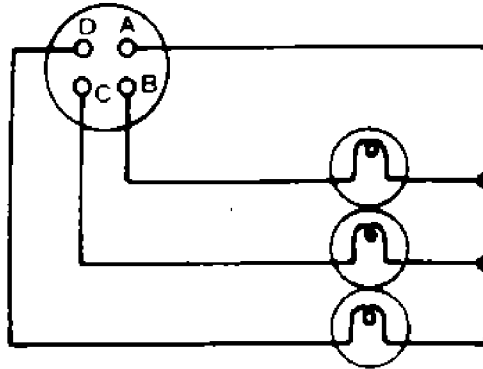

- ① Red
- ② Green
- ③ Orange
- ④ Monitoring receptacle for pilot lamp

- A : Earth
- B : Compressor (Green)
- C : Defrost (Red)
- D : Inrange (Orange)

(2) How to judge operation state by pilot lamps and function of the components.

Names of parts	Temperature setting of chilled mode Above $-2.9^{\circ}\text{C}$ ( $+26.8^{\circ}\text{F}$ )			Temperature setting of partial frozen mode $-3 \sim -10^{\circ}\text{C}$ ( $+26.6 \sim +14^{\circ}\text{F}$ )		Temperature setting of frozen mode Below $-10.1^{\circ}\text{C}$ ( $+13.8^{\circ}\text{F}$ )		Defrost Operation	Water cooled operation (Air/water cooled type)		
	Pull down	In range	Heat-up	Pull down	In range	Pull down	In range				
Pilot lamps	Defrost-Red		×	×	×	×	×	×	○	Water cooled condition is the same as air cooled except ○ Water pressure switch(63W)-Open ○ Condenser fan motor(MF2) De-energized ○ According to conditions, one of two condenser fan motors rotates even though water cooled operation	
	Comp. ON-Green		○	○	○	○	○	○ or ×	○		
	In range-Orange		×	○	×	×	○	×	○		
Magnetic switches	Compressor, condenser fan motor(88C)		○	○	○	○	○	○ or ×	○		
	Evaporator fan motor in low speed(88EFL)	Controlled air temperature Above $20^{\circ}\text{C}$ ( $68^{\circ}\text{F}$ )	○	○	×	○	×	○	×		
	Evaporator fan motor in high speed(88EFH)	Controlled air temperature Below $15^{\circ}\text{C}$ ( $59^{\circ}\text{F}$ )	○	○	○	○	×	×	×		
Solenoid valves	20R1		○	○	○ or ×	○	○	○ or ×	○		
	20R2		○	○	×	○	○	○	×		
	20R3	Temperature setting in Above $10^{\circ}\text{C}$ ( $50^{\circ}\text{F}$ )	×	×	×	○	○	×	×		×
		Temperature setting in Below $9.9^{\circ}\text{C}$ ( $49.8^{\circ}\text{F}$ )	○	○	○	○	○	×	×		×
	20R4		×	×	×	×	×	×	×		○
20M		×	○	○	×	○	×	×	○		
Compressor · MC			○	○	○	○	○	○ or ×	○		

Note ○ : Energized or ON × : De-energized or OFF

### 3. Trouble and countermeasures

If the unit does not work properly, inspect it in accordance with "Trouble and countermeasures" to find causes of trouble and provide appropriate countermeasures.

#### Trouble and countermeasures

State	Phenomena	Functioning places	Cause of trouble	Countermeasures
I. Unit does not operate.	A : Evaporator fans, condenser fans and compressor do not operate.	a. No trouble with unit	Electric interruption.	Trace causes of trouble.
			Power plug is not connected to power source receptacle.	Connect power plug to power source receptacle.
		b. Circuit breaker (main circuit) functions	It functions with large current due to short circuit.	Trace causes of trouble
		c. Circuit breaker (control circuit) functions	It functions with large current due to short circuit	Trace causes of trouble
		d. Oil pressure protection switch is functioning.	It is left as it has functioned.	Repair trouble and set reset switch to on.
	e. Controller malfunctions.	Sensor is damaged or other reasons.	Replace controller.	
	B : Evaporator fans operate. Condenser fans and compressor do not operate.	a. No trouble with unit	Controller functions to stop the unit.	—
			Setting of set-point selector is high	Adjust setting appropriately.
	C : Compressor only operates, but evaporator and condenser fans do not operate	Phase sequence controller does not function.	Open phase power supply circuit.	Trace a cause of trouble.
			Phase sequence controller is faulty.	Replace faulty phase sequence controller.
II. Unit can operate but stops soon.	A : Condenser fans and compressor stop, keeping evaporator fans in operation.	a. Oil pressure protection switch is functioning.	Oil pressure will not rise. Oil is short or oil pump is out of order.	Additional oil charge, or repair oil pump.
		b. No trouble with unit	Controller functions and stops unit.	—
	B : Condenser fans and compressor operate on and off. Evaporator fans continue operating.	a. High pressure switch functions.	Refrigerant is over-charged.	Discharge refrigerant.
			Air is intermixed in refrigeration system.	Purge air
			Cooling air volume is short during air cooled operation.	—
			● Condenser is clogged or air passages are blocked.	Clean condenser or remove obstacles
			● Fan blades are damaged.	Repair faulty fan blades or replace them.
			● Fan motor does not rotate.	Check electric wiring.
			Fan motor protective thermostat functions.	Trace causes of trouble.
			Cooling water is insufficient during water cooled operation.	—
	● Condenser is clogged with scale.	—		
	b. Over-current relay and compressor protective thermostat function.	Current is excessively large due to over-load operation. Open phase power supply circuit.	Trace causes of trouble.	

State	Phenomena	Functioning places	Cause of trouble	Countermeasures
II. Unit can operate but stops soon.	C : Condenser fan and compressor operate. Evaporator fan operates on and off.	a. No trouble with unit.	One minute stopping of fan after defrosting.	—
		b. Protective thermostat is activated.	Coil temperature rise due to overcurrent to fan motor.	
III. Inside temp. is low than temperature setting	Compressor does not stop. (In frozen operation)	a. Controller does not function.	Sensor is disconnected	Replace sensor.
		b. Sensor is installed incorrectly.	—	Reattach sensor.
IV. Inside temperature does not drop	Inside temperature does not reach to preset temperature. (Fans and compressor operate.)	a. Solenoid valve does not open.	Solenoid valve is clogged with dust.	Clean solenoid valve or remove obstacles.
		b. Suction pressure is low.	Charged refrigerant volume is short.	Additionally charge refrigerant, find leaking points or repair them.
			Dryer is clogged.	Replace dryer.
			Choked with water.	Replace dryer.
			Gas leaks from feeler tube of expansion valve.	Replace expansion valve.
Loosening of screws for connection of sensor.	Additional tightening of screws.			
V. Water cooled operation is not performed (Air/water cooled type)	Fans continue running although water couplings are connected.	Water pressure switch does not function.	Cooling water becomes insufficient. (Piping system is clogged or leaks.)	Trace causes of trouble
			Water leaks to switch	Repair leaking point.

● **Trouble and countermeasures for defrosting and heating-up operation.**

Read the sequence operation of each operation mode again. If operation does not accord with the sequence operation, take the necessary countermeasures in accordance with the following table.

The red and green pilot lamps light up during defrosting, and the green pilot lamp lights up during heating-up operation.

Phenomena	Functioning places	Causes of trouble	Countermeasures
Compressor stops soon after starting defrosting (heating-up).	No trouble with unit.	Unit stops for 20 seconds by timer.	—
Compressor operates on and off.	High pressure switch function.	Measuring liquid solenoid valve (20R2) is not closed.	Clean solenoid valve or remove obstacles.
Compressor continues to evacuate for 90 minutes.	Main liquid solenoid valve (20R1) is not opened.	Low pressure switch is faulty.	Replace faulty low pressure switch.
		Wrong wiring for measuring liquid solenoid valve (20R2) and main liquid solenoid valve (20R1).	Check wiring.
It takes 90 minutes to defrost although frost collected is small.	No trouble with unit.	It takes time to defrost because of low ambient temp.	—
	Defrost termination thermistor does not open.	Defrost termination thermistor is faulty.	Replace defrost thermistor.
Cooling operation continues for 13 hours or more and defrosting will not start.	Controller does not function.	Controller is faulty.	Replace faulty controller.
Defrosting and freezing operation repeat every 4 hours.	No trouble with unit.	Inside temperature is out of in range temperature.	—



### 4. PTI (Pre Trip Inspection)

To keep the unit in good operating condition, check adjust or repair the unit when necessary. The following is the checking items of PTI (an example of container refrigeration unit checklist).

Container refrigeration unit inspection card										DAIKIN INDUSTRIES, LTD.		
Ship's name			Unit Model			Date of Inspection						
Container No.			Unit No.			Place of Inspection						
Loaded or empty			Loaded cargo			Compressor No.			Customer's staff			
						Service staff						
No	Result			Check point	Check method	Reference value						
	DECOS	WKM	RMC									
check before operation	1				External appearance and installation of unit (doors, equipment mount, damaged points)	Visual						
	2				Cleaning interior and exterior of unit	Visual						
	3				Checking smudge of unit (air cooled condenser, evaporator)	Visual						
	4				Checking penetration between inside and outside of unit	Visual						
	5				Checking leakage of gas and oil on refrigerant circuit (mainly at joints)	Gas defector Visual						
	6				Checking external appearance of power cable and plug	Visual						
	7				Cleaning drain hose	Visual			Shall be free from clogging			
	8				Mounted condition of electric heaters	Visual			Make sure that leads are not in contact with heaters			
	9				Cleaning defrost air hose and checking that there is no trap on it	Visual			Shall be free from clogging			
	10				Checking appearance of firestat	Visual			Shall have no damaged part			
	11				Checking appearance of over heat thermistor	Visual			Shall have no damaged part			
	12				Tightened condition of cable glands and monitoring receptacle	Retighten			Make sure that they are firmly tightened			
	13				Checking installation bolt of compressor, fan and fan motors	Retighten with tool			Make sure that they are firmly tightened			
	14				Clearance between fan and fan guide	Visual			Shall be kept suitable clearance			
	15				Sealing at control box, and P.S box, etc	Visual			Packing and sealing Shall have sufficient contact			
	16				Slackness of electric terminals and appliance installation	Visual, driver						
	17				Thermal injury of contactors, relays, and coils	Visual						
18				Insulation resistance	Compressor circuit <input type="checkbox"/> MΩ Electric heater circuit <input type="checkbox"/> MΩ Evaporator fan motor circuit <input type="checkbox"/> MΩ	DC 500V megger			2MΩ or more			
19				Checking operation of defrost initiation air switch	Check with manometer			5HP 20mm H <sub>2</sub> O CUT IN 7 1/2HP 25mm H <sub>2</sub> O CUT IN				
Check during operation	20				Checking operation of oil pressure switch	Confirm normal function during running			1.0 kg/cm <sup>2</sup> (110Sec. at 25°C) 0.5 kg/cm <sup>2</sup>			
	21				Checking noise and vibration of compressor, fans and fan motors	Touch and listen						
	22				Checking circulating refrigerant	Check liquid indicator			Make sure that it is filled			
	23				Checking water ingress in refrigerant	Check liquid indicator			Green · sporan/Deep blue · Alco			
	24				Checking compressor oil level (operating condition)	Check at compressor oil level gauge			⊖ (Oil level 1/4 ~ 3/4)			
	25				Checking operation of controller and pilot lamps	Check with changing temperature setting and check pilot lamps						
	26				Checking accuracy of recorder (at inside temperature 0°C)	Measuring temperature with controller or thermometer						
	27				Confirming function of recorder and battery	Visual or check with battery checker						
	27				Checking manual defrosting operation	Manual defrost switch or test switch on controller						
	28				Electric heater Operation and current R <input type="checkbox"/> S <input type="checkbox"/> T <input type="checkbox"/>	Clamp meter						
	29				Checking function of defrost termination	Visual (lamp or controller)						
	30				Unit operation current R <input type="checkbox"/> S <input type="checkbox"/> T <input type="checkbox"/>	Clamp meter -18°C <input type="checkbox"/> V <input type="checkbox"/> Hz						
	31				Checking operation of dual pressure switch	H-CUT OUT <input type="checkbox"/> kg/cm <sup>2</sup>	Blind air inlet			20 kg/cm <sup>2</sup>		
						L-CUT OUT <input type="checkbox"/> mm Hgv	Accomplish pump down by use of the stop valve at the accumulator receiver or water cooled condenser		40 mm Hgv			
						L-CUT IN <input type="checkbox"/> kg/cm <sup>2</sup>			0.2 kg/cm <sup>2</sup>			
	32				Checking operation of water pressure switch	Checking switch over from water-cooled to air-cooled operation	Disconnect water coupling			Condenser fan motor shall operate		
						Checking switch over from air-cooled to water-cooled operation	Connect water coupling and supply water			Condenser fan motor shall stop		
	33				Checking voltage change over	Checking 200V class operation	Turn voltage selector lever upward (LKE TYPE) downward (LK TYPE)					
						Checking 400V class operation	Turn voltage selector lever downward (LKE TYPE) upward (LK TYPE)					
34					Inside temperature °C <input type="checkbox"/>	0°C	-18°C	Automatic operation at -18°C				
					Ambient temperature °C <input type="checkbox"/>			in one cycle				
					LP kg/cm <sup>2</sup> <input type="checkbox"/>			COMP, OFF <input type="checkbox"/> M				
					HP kg/cm <sup>2</sup> <input type="checkbox"/>			COMP, ON <input type="checkbox"/> M				
34					Operating time <input type="checkbox"/> Hr	Operation Starting <input type="checkbox"/> Hr	Automatic Operation <input type="checkbox"/> Hr					
					Immediately after operation	0°C <input type="checkbox"/> M	-18°C <input type="checkbox"/> M	Operation <input type="checkbox"/> M				
35				Checking automatic defrosting	Defrost time <input type="checkbox"/> M	Push the "DEFROST TEST" (DECOS ONLY)		defrost starts (out-range : 14sec. after taking in-range : 43sec.)				
36				Place new chart								
37				Close control box and PS. box, etc.								
38				Record details of service on history cards								



## 5. Major components and maintenance

### 5.1 Components related with refrigeration circuit

#### 5.1.1 Compressor

The compressor is of a semi-hermetic type with the built-in motor so that there are few places where leakage of refrigerant may occur. The reversible trochoid pump used produces the required oil pressure regardless of the direction of rotation of the built-in motor.

##### ① Replacement

Remove the compressor by the following procedure.

- 1) Remove the front and base plates and protective stay of the cable stowage.
- 2) Remove the discharge stop valve, suction stop valve gauge piping flare nut (compressor side) and cable.
- 3) Remove four bolts (two on each side) fastening the compressor and base.
- 4) Take out the compressor to the front of the unit.

##### ② Installing procedure

Install the compressor according to reverse procedure given above. When tightening the bolts, refer to the list for torque.

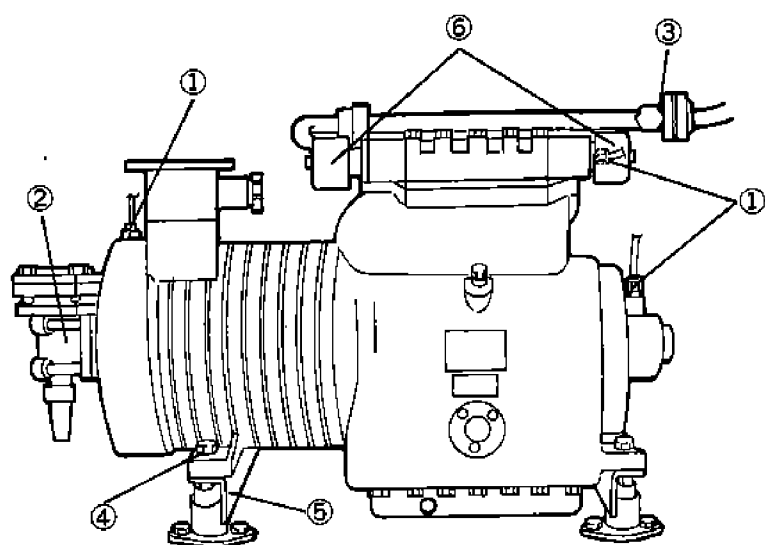

- ① Gauge piping flare nut
- ② Companion flange for compressor suction side
- ③ Stop valve at compressor discharge side
- ④ Bolt
- ⑤ Base
- ⑥ Unloading solenoid valve

#### 5.1.2 Air cooled condenser and evaporator

Of the "cross fin" coil type having special corrugated fins are compact and very efficient in producing uniform heat exchange efficiency.

##### Maintenance

Service the air cooled condenser after removing the front panel. Service the evaporator after removing the inside access panels.



Air cooled condenser

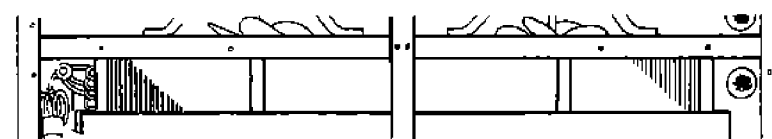

Evaporator

#### 5.1.3 Water cooled condenser (Air/water cooled type)

##### Receiver (Air cooled type)

The water cooled condenser is mounted in case of the air/water cooled type and the receiver is installed in case of the air cooled type. Since the condenser is of the shell and coil type, cooling water flows in the inner cooling tubing and the refrigerant flows in the condenser shell. The cooling tubing having special fins are used to make it light and compact.

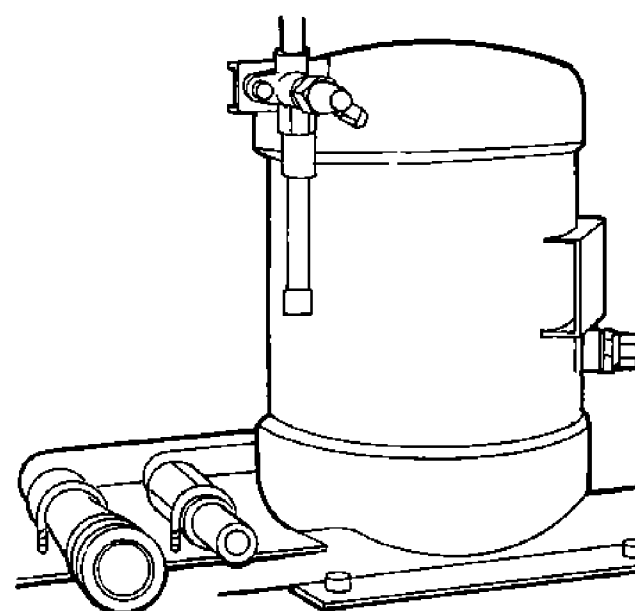

### Replacement procedure of the fusible safety plug

When pressure rises abnormally in the system, the fusible plug melts itself, so if the fusible plug is melted check possible causes thoroughly.

When fusible plug functions, the centre of the fusible plug alloy ② melts, from which the refrigerant jets out. When the flare nut is removed, ① is apt to come out by pressure and clogs the passage of the refrigerant outlet, which prevents the refrigerant from jetting out and also the air from entering. Thus, refrigerant loss is extremely minimized.

Insert a new ② with ③, and tighten the flare nut.

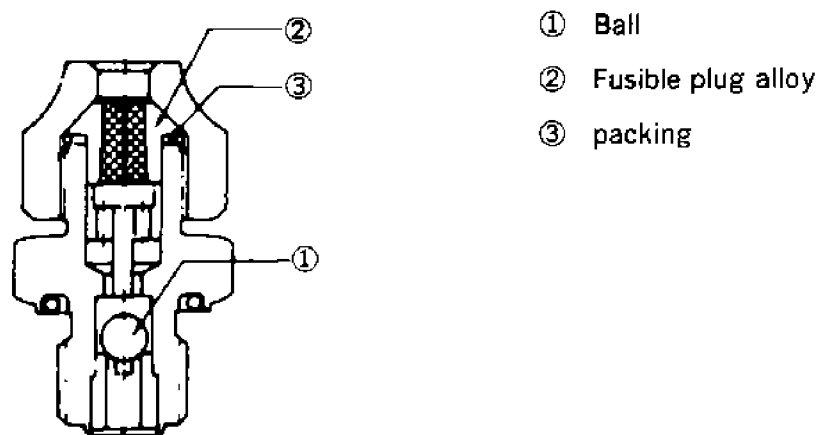

Construction of fusible safety plug

- ① Ball
- ② Fusible plug alloy
- ③ packing

### 5.1.4 Expansion valve

The externally equalized thermal expansion valve which is fitted before the evaporator and senses super-heat degree of leaving evaporator refrigerant and controls flow of the refrigerant automatically according to operating conditions. The expansion valve with MOP. (MAXIMUM OPERATING PRESSURE) is adopted to protect the compressor motor from overload.

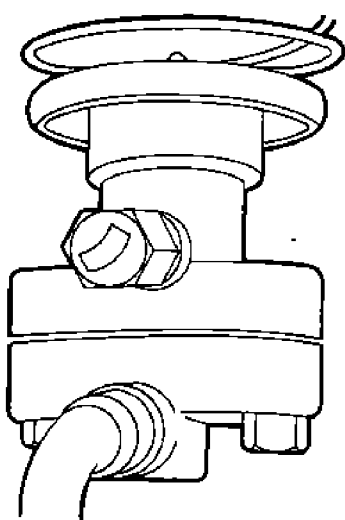

**"CAUTION"** Whenever adjusting and replacing the expansion valve, the unit should be stopped securely for safety sake.

#### ① Adjusting the expansion valve

There are two methods to adjust the expansion valve; i.e, one is the adjustment based on the suction operation standard and the other is that based on the frost conditions on the compressor.



#### a. Adjustment based on the suction operation pressure

- 1) Confirm that the predesigned volume of the refrigerant has been charged.
- 2) Attach a pressure gauge to each gauge port and operate the refrigeration unit, maintaining inside temperature at  $-18^{\circ}\text{C}(-0.4^{\circ}\text{F})$ . (refer to 'Maintenance').
- 3) When inside temperature comes to the preset temperature, compare the suction pressure reading with the standard pressure. (refer to 'Standard operation pressure curve')
- 4) If suction pressure reading differs with the standard pressure, adjust the expansion valve as stated below.
- 5) After loosening the clamp screw, turn the adjusting screw.
- 6) Note that pressure will not change after a certain lapse of time.

#### b. The adjustment based on frost stated on the compressor.

- 1) Refer to the caution for adjustment of expansion valve as above. At this time, inside temperature should be maintained to  $-18^{\circ}\text{C}(-0.4^{\circ}\text{F})$ .
- 2) Regulate the adjusting screw as stated below based on frost state on the suction pipe and the stop valve of the compressor.
- 3) Whether or not the adjustment required is judged by frost state of the flange on the suction side of the suction valve.
- 4) However note that frost state differs with outdoor air conditions (temperature and humidity).

#### c. Adjusting points for expansion valve

- Suction pressure is higher than the standard pressure (Frost forms on the compressor side rather than the suction flange of the stop valve). Clockwise rotation of the adjusting screw decreases running pressure. 
- Suction pressure is lower than the standard pressure (Frost forms on the suction pipe rather than the suction flange of the stop valve). Counterclockwise rotation of the adjusting screw increases running pressure. 

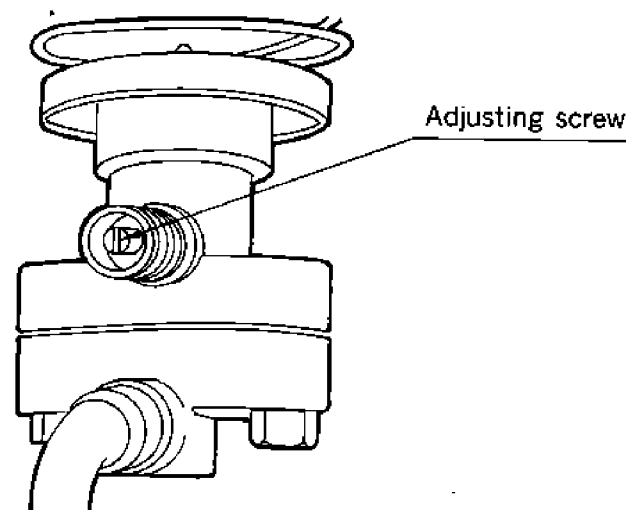

**d. Countermeasures after operation**

- 1) Remember the original setting of the expansion valve. If any change is found with the setting after adjustment of the expansion valve, return the adjusting screw to the original position, as trouble occurred caused by other reasons.
- 2) When the adjusting screw is returned to its original position, firstly turn it passing the original position and then return it to the original position.
- 3) After adjustment, be sure to tighten up the clamp screw and cap it to prevent the refrigerant from leaking.
- 4) After completion of the adjustment, operate the unit, keeping inside temperature at  $-18^{\circ}\text{C}(-0.4^{\circ}\text{F})$  and confirm that low pressure does not go down below standard operation pressure

**② Replacement**

Remove the access panel, the front panel of the air cooled condenser fan and fan guide which are located outdoors, before undertaking the work.

- 1) Remove the feeler tube, equalizing pipe flare, and fastening bolts. (To replace the cage alone, there is no need to remove the feeler tube.)
- 2) Remove the power assembly, cage, and packing.
- 3) Be sure to install a new packing when replacing it.

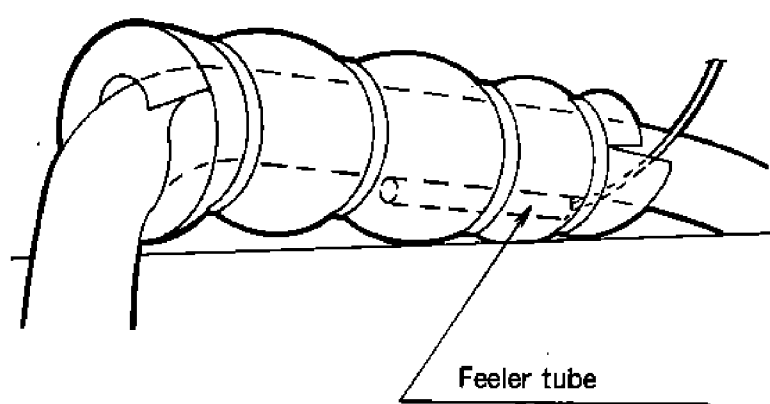

**5.1.5 Liquid/moisture indicator**

This indicator permits checking of flow of the refrigerant and moisture content in the refrigerant.

**① Moisture content**

- The indicator indicates moisture content by the color at the center of the window.

Check this indicator during the unit is operating.

Color	State
Deep blue	Dry
Orange	Wet (moisture contained)

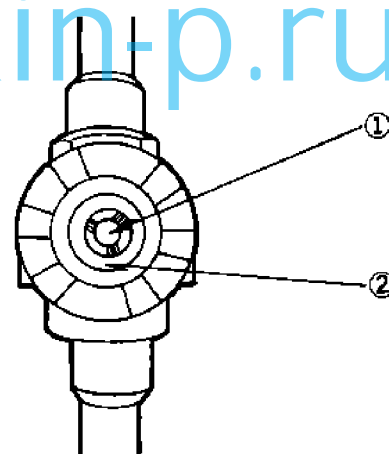

- ① Moisture indicator
- ② Corrugated glass

- Note:**
1. The indicator may appear orange if it has been exposed to gaseous refrigerant for a long time.
  2. The indicator is to be checked at being sealed with liquid refrigerant after operating for a few hours.
  3. Change of the indicator is influenced by the temperature of liquid refrigerant. The lower temperature cause the change of indicator to take the longer time.
  4. To shorten the time for change of indicator, raise up the temperature of liquid refrigerant.

**② Flow of the refrigerant**

- When the liquid refrigerant is sealed, corrugation on the sight glass disappears.
- Check

Operation	Indicator state
At start	Bubbles appear but liquid refrigerant is sealed in 30 minutes to an hour after starting.
During operation	Bubbles may appear more or less.

If bubbles develop continuously, the refrigerant is possibly running short.

**③ Replacement**

- 1) Put the system in "pump down" state.
- 2) Turn the sight glass counterclockwise, and remove it together with the O-ring.
- 3) Apply refrigeration oil to the new O-ring, and fasten the sight glass with torque of  $70 \pm 5$  kg-cm. (Do not apply excessive torque, or the O-ring will break.)

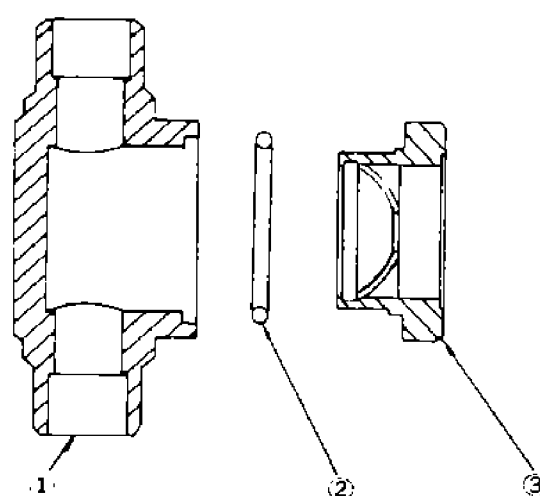

- ① Body
- ② O-ring
- ③ Sight glass

**5.1.6 Dryer**

This removes moisture and dust from the refrigerant while it is circulated. Replace the dryer if it does not remove moisture or is clogged.

When installing the new dryer, follow the directions given on the nameplate and do not make any mistake about the direction of the dryer.

**Replacement**

- 1) In "pump down" state (refer to "Maintenance"), close the compressor suction stop valve.
- 2) Then, loosen the flares (the flange bolts) at the both end of the dryer and replace the dryer quickly.
- 3) Be careful not to get air into the piping on the solenoid valve side while removing the dryer.
- 4) After reattachment of the dryer, open the stop valve a little to purge the air in the dryer from the flare (flange) on the solenoid valve side and then close it at once.
- 5) Loosen the flare (the flange bolt) on the other side, turn on the unit ON/OFF switch instantly and open the solenoid valve only to purge the air.
- 6) After completion of the work, open the stop valves to its original state and then inspect the system for gas leakage. Confirm no gas leakage is found.

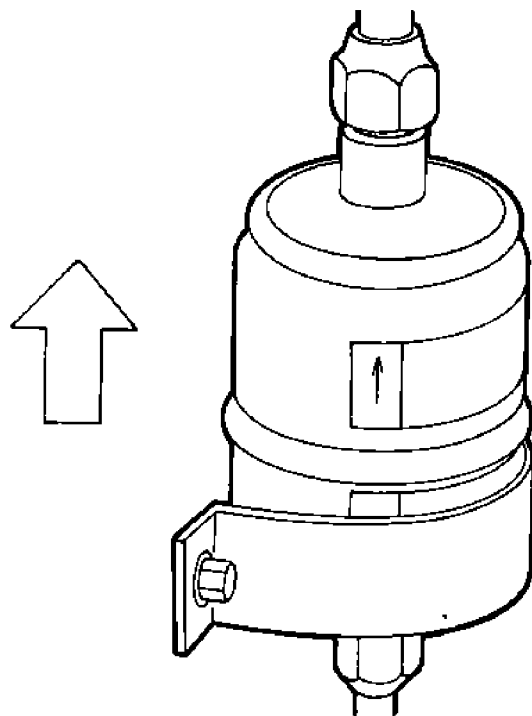

**5.1.7 Solenoid valves**

① **Solenoid valves in the liquid line (20R1, 2)**

20R1, 2 are opened or closed by the signal of the controller.

When 20R1, 2 are closed, the refrigerant flow is blocked.

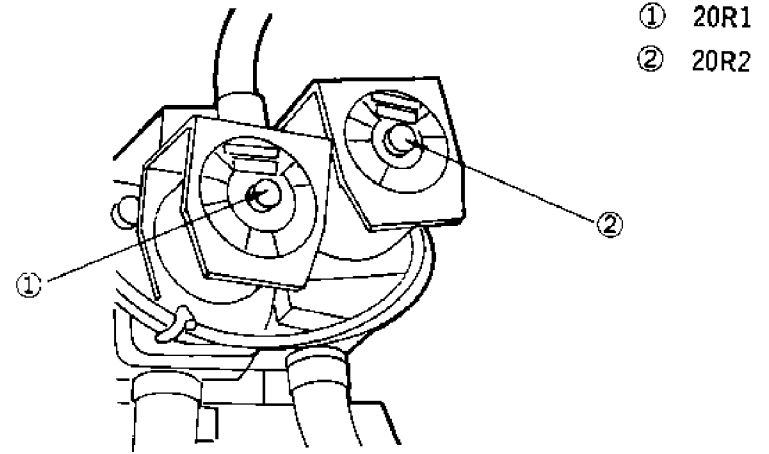

**Disassembly**

- 1) The structure of the solenoid valve is shown at right. (For disassembly, checking, and reassembly, refer to this diagram.)
- 2) When brazing a pipe to the valve, cool the valve body with a wet cloth. (It is not required to disassemble the valve. Remove the coil ass'y from the body.)
- 3) During reassembly, tighten the four bolts×4 with torque of 50–60 kg-cm.

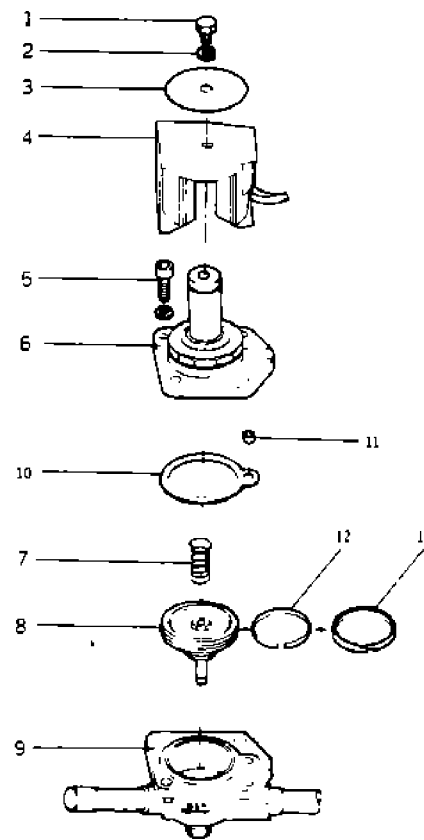

No.	Parts name
①	Set bolt (M5)
②	Spring lock washer (M5)
③	Name plate
④	Coil ass'y
⑤	Set bolt
⑥	Cover ass'y
⑦	Spring
⑧	Piston
⑨	Valve body
⑩	Packing
⑪	Sleeve
⑫	Inner ring
⑬	Piston ring

② **Three-way solenoid valve for drain pan heater (20R4)**

- Model: DHV804DXF
- Power supply: AC 24V, 50/60Hz

The three-way solenoid valve is provided to change the discharge gas flow to the evaporator.

During chilled or partial frozen operation, the discharge gas flow to the evaporator directly and during defrosting, it flows to the evaporator through the drain pan heater.

a. Piping connection

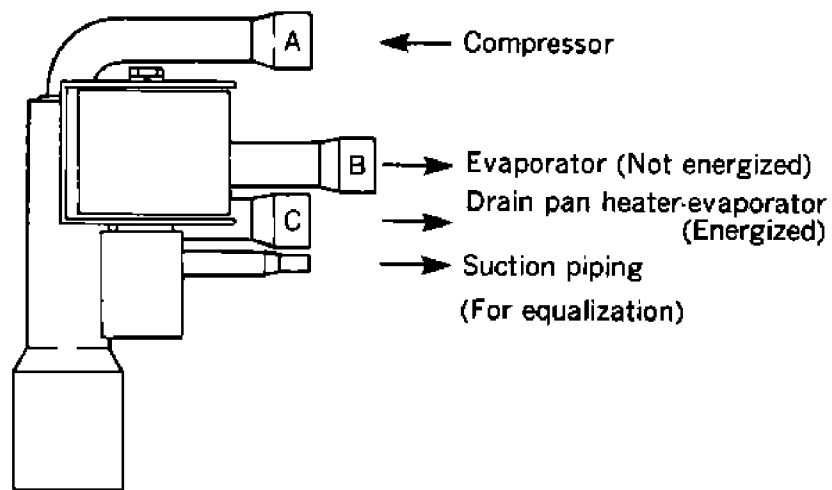

(2) Replacement of valve body

Before brazing the valve body, remove the coil and braze it while cooling it sufficiently (under 120°C [248°F] )with water-moistened cloth.

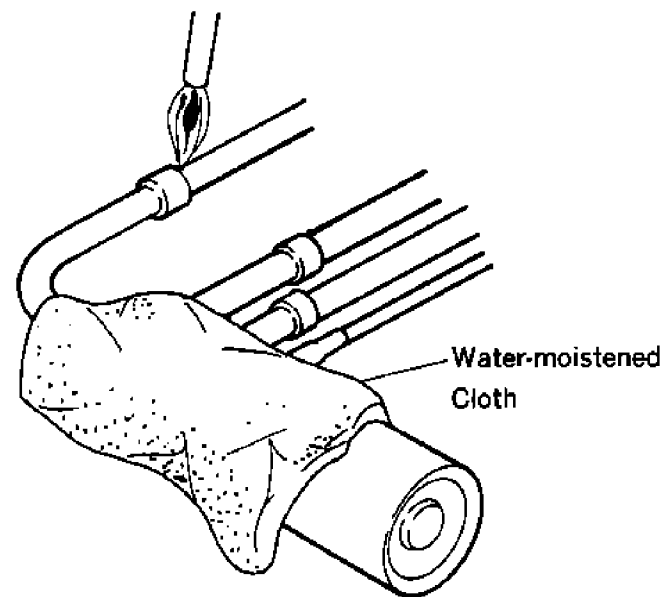

b. Replacing method

(1) Replacement of coil

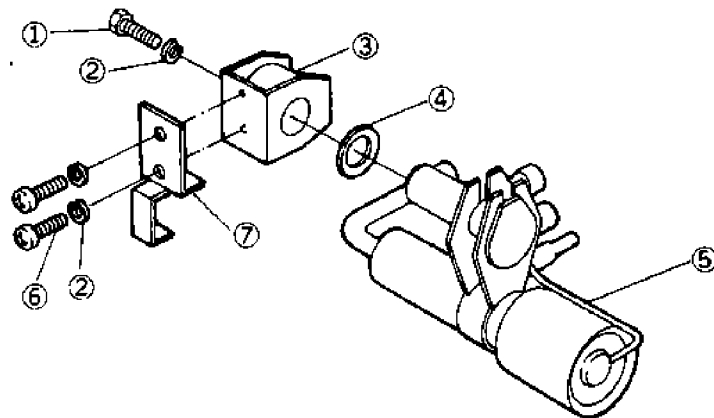

No.	Parts name
①	Set bolt (M4)
②	Spring lock washer (M4)
③	Coil
④	Washer
⑤	Valve body
⑥	Set screw (M4)
⑦	Bracket

**5.2 Components related with the air system**

**5.2.1 Fans and motors**

① Specifications

		Evaporator	Condenser
Fan	Type	Propeller fan	
	Numbers of blades	6 pcs.	
	Blade diameter	φ300	φ260
Motor	Type	3 phase squirrel-cage induction motor	
	Motor output (Pole numbers)	420/700W(2P) 60/90W(4P)	200/330W(4P)
	Bearing	Ball bearing, 6203 Non-contacting type Rubber seal	

② Installation procedure

a. Evaporator fan and motor

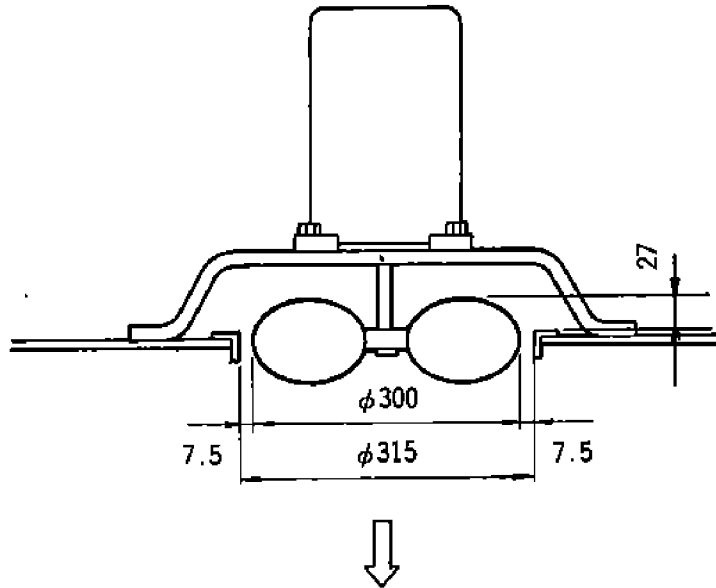

b. Condenser fan and motor

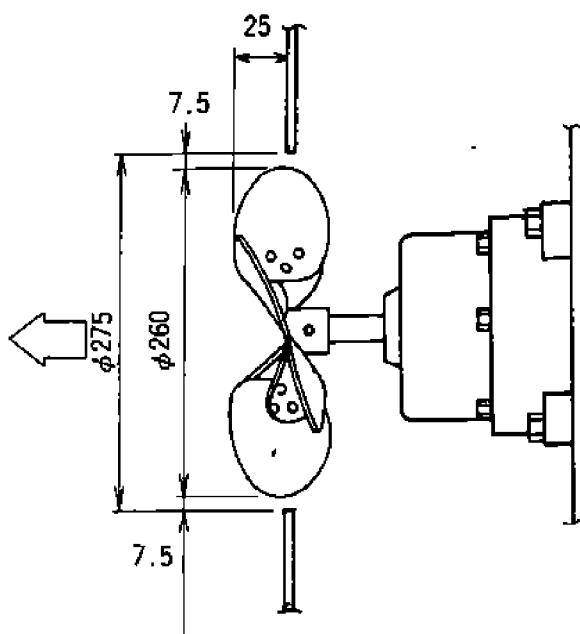

③ Replacing method for evaporator fan

Before removing the evaporator fan, loosen the bolts on the fan motor and remove the motor.

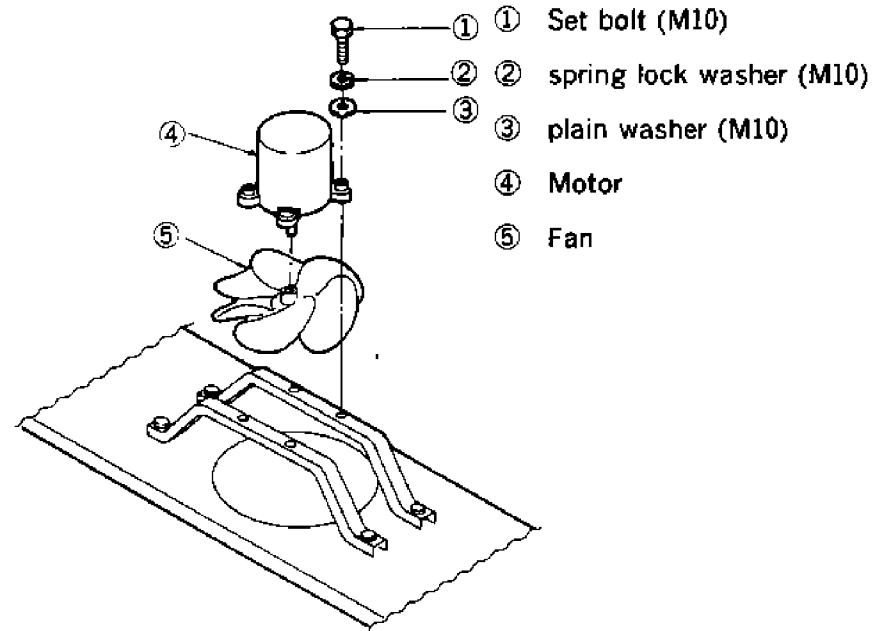

**5.2.2 Ventilator**

**Handling method**

1) In case ventilation is not needed:

Set the handle to "CLOSE".

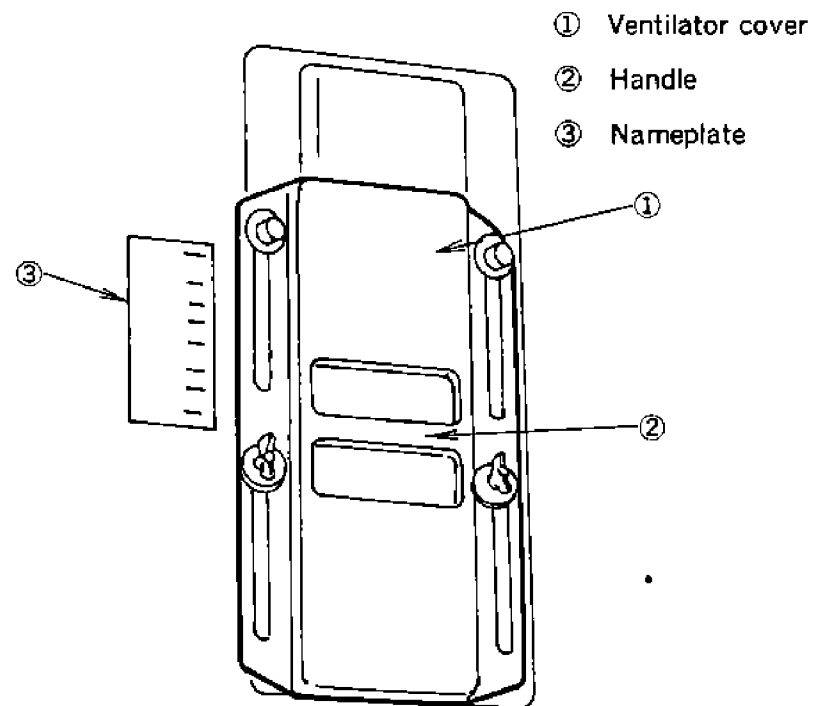

2) In case ventilation is needed:

Set the handle to "FULL OPEN".

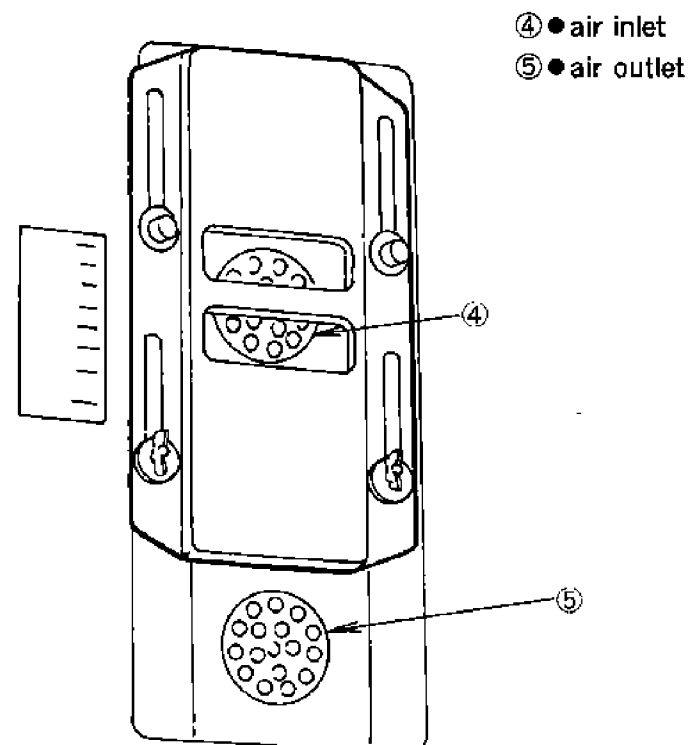



### 5.3 Functional electric parts

#### 5.3.1 High pressure switch (63H1)

This switch causes compressor to stop, as the operation pressure of the unit has risen abnormally. Thus HPS is adapted to stop the compressor if the high pressure has gone up above its set value due to failure of condenser fan, obstructive passage to cooling water, etc.

#### 5.3.2 Low pressure switch (63L)

When low pressure is lower than the predesigned value due to measured pump-down during defrosting or heat-up operation, this switch switches over the solenoid valve, detecting termination of measuring

#### 5.3.3 High pressure control switch (63H2)

If the ambient temperature is low during air cooled operation, one out of two condenser fans are turned off so that the high pressure should not fall. (As for more details, refer to "high pressure control")

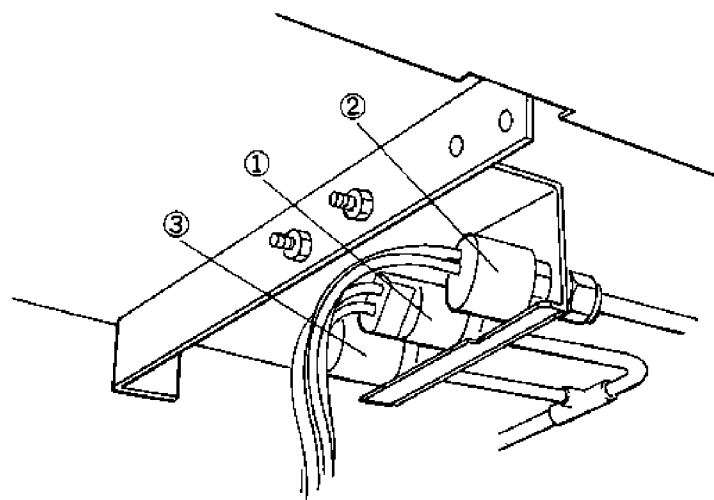

- ① High pressure switch (63H1)
- ② Low pressure switch (63L)
- ③ High pressure control switch (63H2)

#### 5.3.4 Water pressure switch (63W) (Air/water cooled type)

This switches over air and water cooled modes. If coolig water flows and water pressure rises above a preset water pressure at the inlet, the contact is turned off to stop the condenser fan motor and water cooled operation will start.

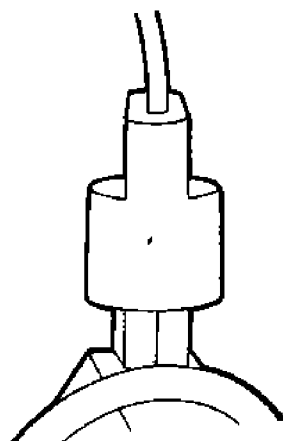

#### 5.3.5 Oil pressure protection switch(63QL)

Oil pressure (difference between oil pressure and low pressure) falls due to oil pump failure, clogging and oil foaming.

This stops the compressor automatically when oil pressure continuously remains low, because the compressor may be burnt because of oil shortage.

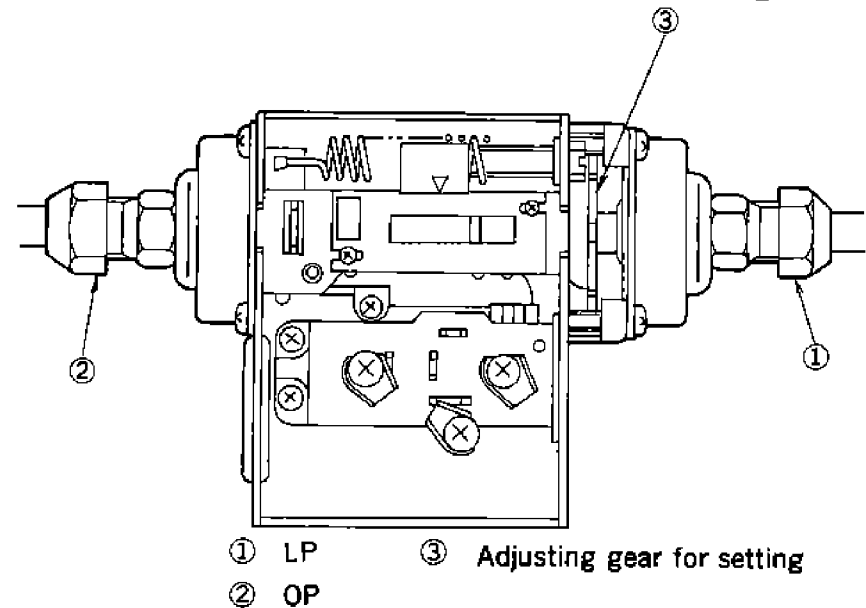

#### ① Operation

When the compressor is started, the oil pressure (differential pressure) rises, and the differential pressure contacts of the oil pressure protection switch (63QL) are opened. However, if the oil pressure fails to rise for over 110 seconds after starting the compressor, the contacts are closed and the timer operates to stop the compressor.



#### ② Reset

When the oil pressure protection switch (63QL) is activated, turn on the oil pressure reset switch (3-QL). The unit will operate automatically after a lapse of 2 minutes (If the reset switch is turned on within 2 minutes after activation of the oil pressure protection switch, the display for "E.o.P" is frickering.

#### ③ Adjustment method

Adjust the oil pressure protection switch.by turning the adjusting gear as described below.

#### Adjusting points for oil pressure protection switch

- When rotate the adjusting screw clockwise, functional pressure (differential) becomes low and differential pressure contact is turned off with low pressure difference. 
- When rotate the adjusting screw counterclockwise, functional pressure (differential) becomes high and differential pressure contact is turned off with high pressure difference. 

**Note:** The following turning directions are viewed from the low pressure connection side.

### 5.3.6 Recorder (SKM-2924A)

#### ① Specifications

- Model SKM-2924A
- Feeler tube Gas sealed
- Recording method Pressure sensing type
- Recording temperature range  $-29.9 \sim +25^{\circ}\text{C} (-22 \sim +77^{\circ}\text{F})$
- Recording paper Dia. 203 Disk type pressure sensible paper (Graduation  $1/1^{\circ}\text{C}$ ) (Corresponding to PSD-217C (REV. A) made by PARTLOW Co.)
- Driving method for recording paper Timer (Quartz motor + reducing gears) a turn/31 days  
Quartz motor driving source: Goods corresponding to Dry battery (DC 1.5V)  
JIS C 8501.....SUM2  
IEC .....R14  
Life is approx. 1 year (Remaining voltage indicator)

#### ② Inspection of recorded temperature

##### Recording pen on chilling

Operate the unit in chilling mode at  $0^{\circ}\text{C}$  ( $32^{\circ}\text{F}$ ) setting and confirm with the digital temperature display of the controller that the supply air temperature has stabilized at  $0^{\circ}\text{C}$  ( $32^{\circ}\text{F}$ ). Then rotate the digital temp. indication switch to return air and calibrate the recording pen according to the return air temperature on digital display.

#### ③ Adjustments

- 1) Make adjustments subsequent to the inspection in item.
- 2) Turn the temperature setting screw (A) to adjust the temperature. Loosen the lock screw (B) and turn the setting screw (A) clockwise to temporarily raise the temperature setting by approximately  $5^{\circ}\text{C}$  ( $9^{\circ}\text{F}$ ). Then turn the setting screw (A) counterclockwise to lower the temperature setting of the pen until the temperature is adjusted to the digital temperature. Tighten the lock screw (B) after the adjustment.

- Note:**
- 1 One turn of the setting screw (A) changes the temperature setting by approx.  $5^{\circ}\text{C}$  ( $9^{\circ}\text{F}$ ).
  - 2 Be careful that the temperature setting may be altered by tightening the lock screw (B).

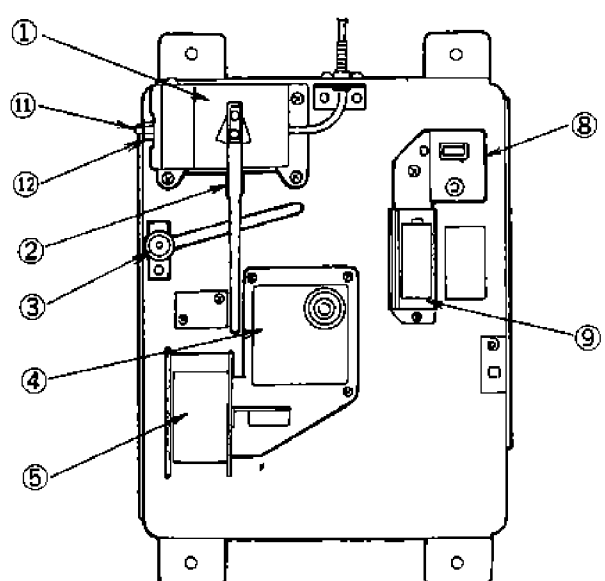
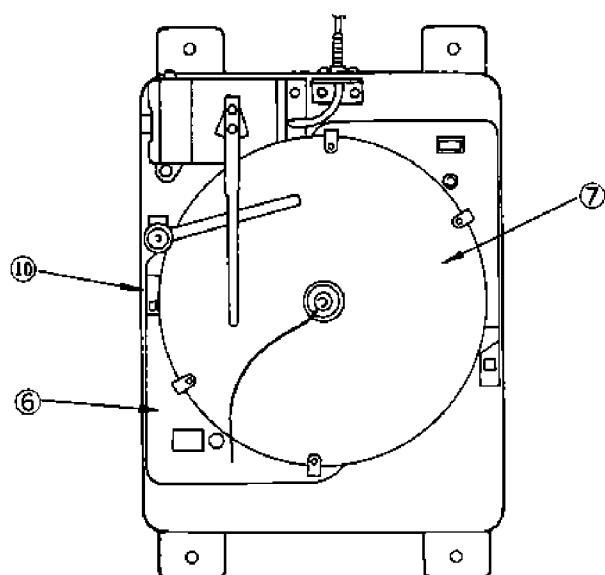

- |                   |                         |
|-------------------|-------------------------|
| ① Element         | ⑦ Recording paper       |
| ② Pen             | ⑧ Remaining V indicator |
| ③ Pen lifting arm | ⑨ Battery               |
| ④ Reducer         | ⑩ Present time plate    |
| ⑤ Quartz motor    | ⑪ Adjusting screw       |
| ⑥ Recording board | ⑫ Lock screw            |

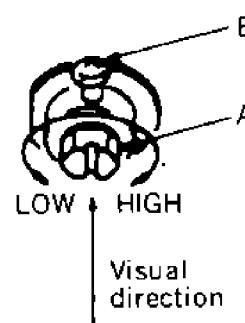

- 3) Generally a temperature recorder should be adjusted at  $0^{\circ}\text{C}$  ( $32^{\circ}\text{F}$ ), but the following method is available when the setting temperature is known.

- Chilled mode (Setting temperature : above  $-2.9^{\circ}\text{C}$  [ $+26.8^{\circ}\text{F}$ ])..... "Adjust at  $0^{\circ}\text{C}$  ( $32^{\circ}\text{F}$ )."
- Frozen mode (Setting temperature : below  $-3.0^{\circ}\text{C}$  [ $+26.6^{\circ}\text{F}$ ])..... "Adjust at  $-18^{\circ}\text{C}$  ( $-0.4^{\circ}\text{F}$ )."

#### 4) Inspection and adjusting method

- adjust a temperature recorder when the container inside temperature becomes decreasing. Temperature recorder's pen shows the temperature correctly when it is decreasing. Don't adjust it when the temperature becomes increasing.

It is caused from its hysteresis that a pen sometimes shows the temperature lower from  $1^{\circ}\text{C}$  ( $1.8^{\circ}\text{F}$ ) to  $3^{\circ}\text{C}$  ( $5.4^{\circ}\text{F}$ ) when the temperature is increasing.

- It is a normal phenomena that the recording curves are a little influenced by the fluctuations of the ambient temperature. (Note : Basically the temperature recorder is designed for  $25^{\circ}\text{C}$  [ $77^{\circ}\text{F}$ ] ambient, and  $10^{\circ}\text{C}$  ( $18^{\circ}\text{F}$ ) fluctuations of the ambient temperature cause the error of  $\pm 0.2^{\circ}\text{C}$ . [ $\pm 0.4^{\circ}\text{F}$ ])



- A temperature recorder adjusted at 0°C (32°F) sometimes shows the following curves at -18°C (-0.4°F) inside. It is a normal and allowable range.  
If the range exceeds the above, readjust it at 0°C (32°F) (or -18°C [-0.4°F]).
- Don't move the pen by hand, because it will cause an increase of error.
- When the pen is held by the pen lifter the pen may move unsmoothly, but it is no problem.

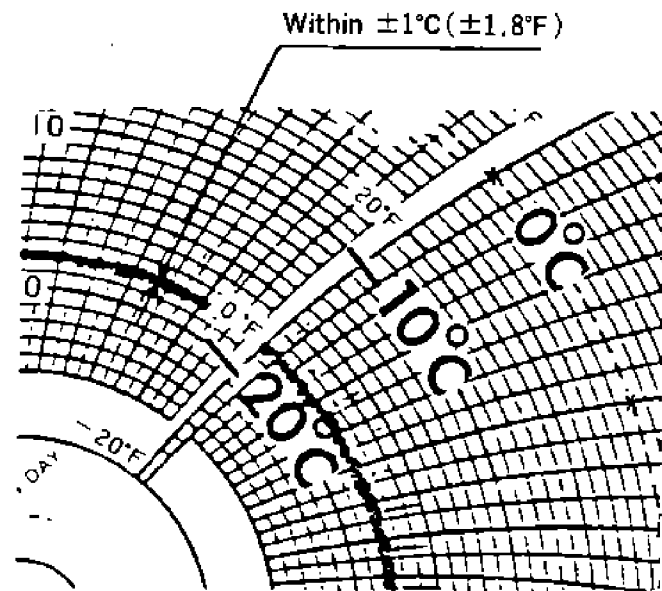

④ Replacement of parts

a. Battery

1) Replacement interval

- When the indicator is out side the blue zone after checking the residual voltage of the battery. (When the indicator is above the dotted lines, i.e., within the white zone shown in the right figure, the battery has approximately one-month life.)

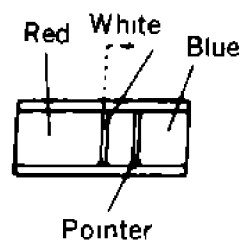

Residual voltage indicator

2) Replacement method

- Remove the recording panel and insert the new battery making certain that the battery polarity is correct. Use SUM-2 of JIS C8501 or IEC R14 battery or the equivalent (DC1.5V dry cell).
- After replacement, confirm that the pointer of the residual voltage indicator is within the blue zone and that the quartz motor functions properly.

b. Residual voltage indicator battery

1) Replacement interval

- In case oscillation of the needle is unstable when the push switch is pressed down for confirmation of remaining voltage.
- In case the remaining voltage indicator needle is within the white zone or in the red zone, although a new battery is set in.

2) Replacement method

- Remove the recording panel by loosening the screw.  
Remove the residual voltage indicator battery from the body, and replace it with a new one.
- When replacing the battery make certain that the terminal wirings are connected red to red and black to black
- After replacement confirm that the pointer is within the blue zone and that the quartz motor functions properly.
- Battery is to be replaced every 12 months.

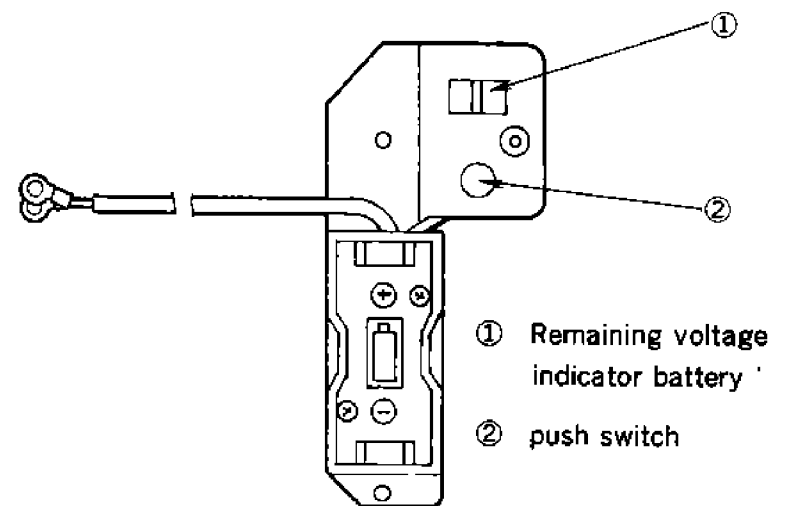

(DKM-AA003)

Residual voltage indicator battery

C. Timer (quartz motor speed reducing gear)

1) Replacement interval

- When the quartz motor does not function even though residual voltage battery is normal.
- When the timer delays over three hours a day.

2) Replacement method

- Remove the recording panel to remove the wiring. Loosen the screws (5 pcs) to remove the timer, and replace the timer with a new one.
- When replacing the timer, also replace the antivibration rubbers (5 pcs). The red wire is for (+) and the black wire for (-), therefore, connect the red terminal with red and the black with black. Tighten the anti-vibration rubbers with torque of 4 ~5kg-cm.
- Confirm that the quartz motor functions correctly after replacement.

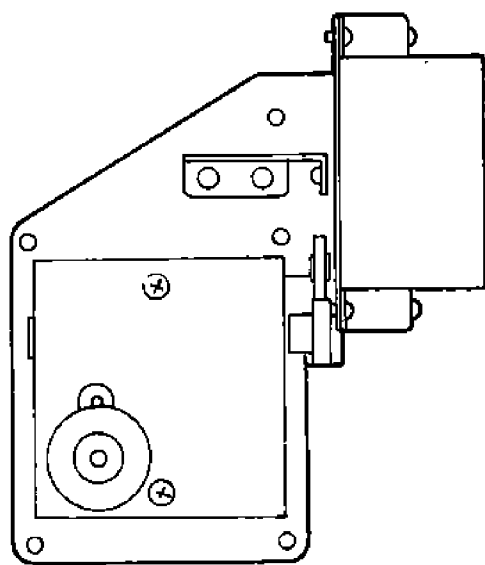

Timer (quartz motor speed reducer)

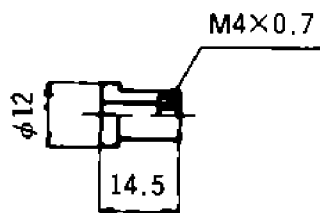

Accessory (anti-vibration rubber : 5 pcs)

d. Thermal feeler tube

1) Replacement interval

- After the pen has been adjusted and the controller has been operated within the temperature range of  $-18$  to  $+10^{\circ}\text{C}$  ( $-0.4$  to  $+50^{\circ}\text{F}$ ), with the inside temperature stabilized at the temperature setting: When the temperature indication under the above conditions deviates by more than  $2^{\circ}\text{C}$  ( $4^{\circ}\text{F}$ ) against the temperature setting. (When the temperature indication is substantially less than the temperature of the thermal feeler tube, gas leakage may be suspected.)

2) Replacement method

- Loosen the screw and remove the thermal feeler tube-element. Replace it with a new one.
- After replacement, inspect and adjust.

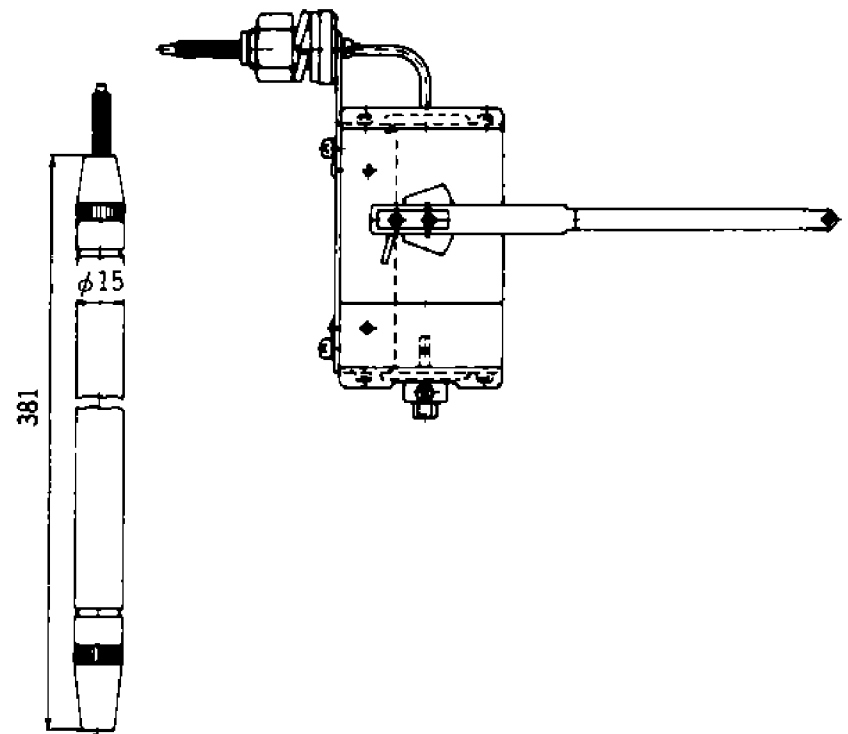

Feeler tube—element ...SKM-AA001

**5.3.7 Phase sequence controller (47)**

① **Specifications**

- Type: PR8601
- Power supply: 190~200V 50Hz  
200~220V 60Hz

The phase sequence controller opens or closes the magnetic contactor for changing-over of phases, detecting phases, R. S. T. in the power supply to prevent the fan motor from reverse turning.

The integrated microcomputer detects voltage of each phase and phase order and operates as tabulated below.

State of power supply		Relay RY1	Relay RY2	Between terminals 1-2	Between terminals 1-3
De-energized period		OFF	OFF	No continuity	No continuity
Energized period	Proper phase	ON	OFF	Continuity	No continuity
	Wrong phase	OFF	ON	No continuity	Continuity
	Single phasing before supplying power	OFF	OFF	No continuity	No continuity
	Single phasing during energization	State before single phasing is retained.			

**Note:** Single phasing can be judged only on the power supplying side, but not on the load side.

② **Checking method for operation**

Exchange the power sources and check that the microcomputer operates as tabulated above. If not, replace the phase sequence controller.

③ **Cautions for replacing the switch**

Correctly connect each terminal in accordance with the wiring diagram. If not the switch may be burnt, or the microcomputer becomes erratic.

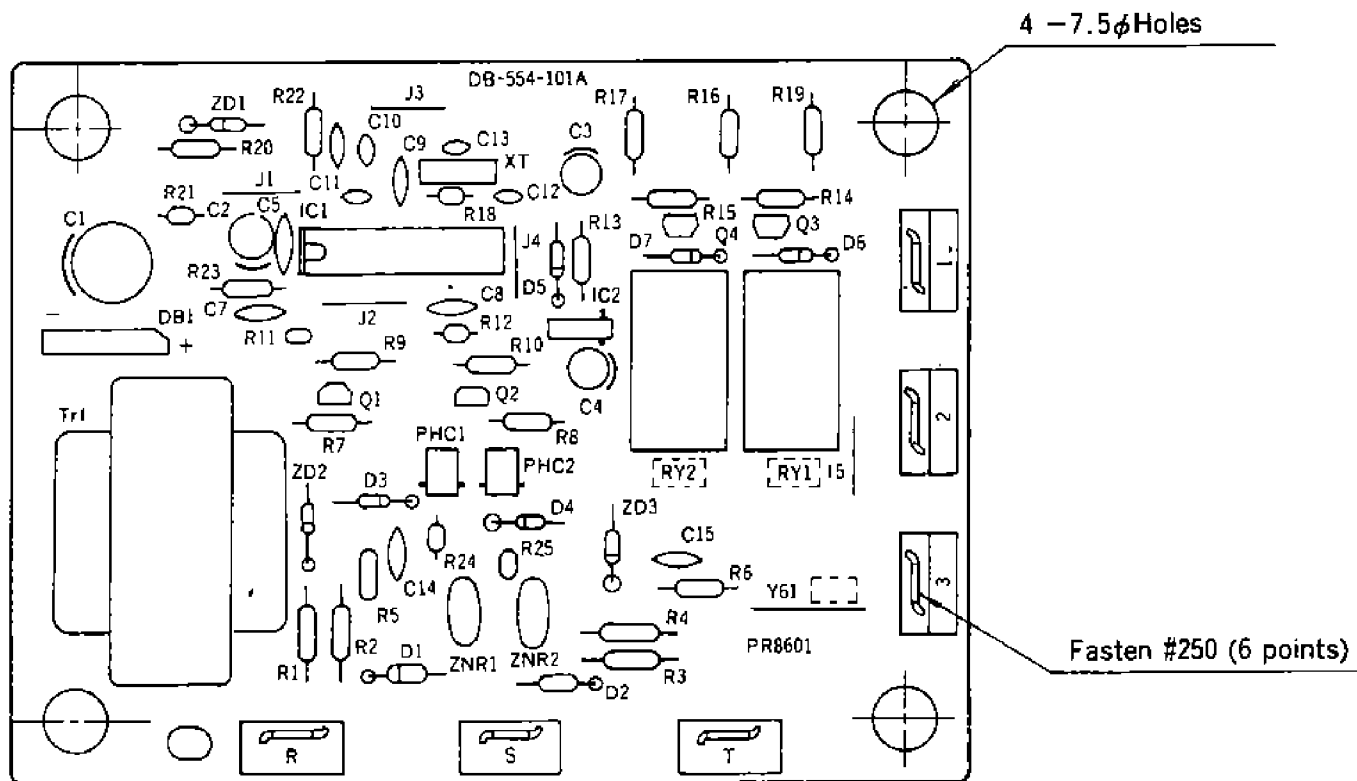

## 5.3.8 Electronic Controller (23A)

### DECOS(Daikin Electronic Container Operation System)

#### ① Specifications

- Power supply: AC24V, 50/60Hz
- Temperature setting range:  $-25.0^{\circ}\text{C} \sim +25^{\circ}\text{C}$  ( $-13^{\circ}\text{F} \sim +77^{\circ}\text{F}$ )

#### ● Sensors:

- S.S: For control of supply air temperature
  - R.S: For control of return air temperature
  - TH: Thermistor sensing element for termination of defrosting.
- Platinized resistance bulb  $0^{\circ}\text{C}$   
100 $\Omega$ 3 wire type

#### ● Electronic timers

- Defrosting timer
  - Short (out of In range) — 4hours
  - Long (in In range) — 12hours
  - Compressor stopping — 20seconds
  - Back-up — 90minutes
  - In range mask — 90minutes
- Delay timer
  - Selection of evaporator fan speeds
    - 10seconds
  - Cold starting — 60seconds
  - Compressor starting — 3seconds

#### ● Outputs

- Relays for ON/OFF
  - CS (For compressor)
  - EFHS (For high evaporator fan speed)
  - EFLS (For low evaporator fan speed)
  - LS1 (For solenoid valve)
  - LS2 (For solenoid valve)
  - ES (For solenoid valve)
  - DS (For solenoid valve)
  - IRS (For In range)
  - DFS (For defrost lamp)
  - US (For unloading solenoid valve)
- Phase control voltage due to PID operation

#### ● Displays

- Digital temperature displays
  - Supply
  - Return
  - Check

Selected with the indication selector switch on the display panel
- Light emitting diodes (LED)
  - Operation displays
    - Outputs of relays (Except US for unloading solenoid valve)
    - Operation mode/Sensor
    - Defrost test
    - Output relay check

#### ● Backup functions

- Control sensor backup function (Supply, return and termination of defrost)
- Defrost backup function
- Evaporator fan motor backup function
- Defrost termination thermostat backup function

#### ● Self-diagnosable and checking functions (Power economization of PTI)

- Relays
- Defrosting
- Sensors
  - Return, Supply, Defrost termination sensors
- Manual defrosting switch
- Oil pressure protection switch
- Reset switch for oil pressure protection switch

#### ● Others

- Oil pressure protection functions
- Cold start function
- In range masking function

② Explanation of operation and displays

1) Temperature setting

- Set the predesigned temperature in of SET POINT SELECTOR.

Range of setting: Variable temperature from  $-29.9$  to  $+29.9^{\circ}\text{C}$  ( $-21.8 \sim +85.8^{\circ}\text{F}$ )  
 In this case, however,  $\pm 25.1 \sim \pm 29.9^{\circ}\text{C}$  ( $-13.2 \sim -21.8^{\circ}\text{F}$  or  $+77.2 \sim 85.8^{\circ}\text{F}$ ) is considered as temperature setting of  $\pm 25.0^{\circ}\text{C}$  ( $-13^{\circ}\text{F}$  or  $+77^{\circ}\text{F}$ )

Notes:

1. Do not stop the switch forcibly.  
Operate the switch so that numerical character appears correctly in the display window.
2. The scale of  $10^{\circ}\text{C}$  moves only among 0, 1, and 2. Do not put unnecessary force on the switch.
3. Do not touch the set-point selector except when setting a desired temperature.
4. If temperature setting exceeds  $\pm 25^{\circ}\text{C}$  ( $-13^{\circ}\text{F}$  or  $+77^{\circ}\text{F}$ ), the check lamp blinks and "E.SP" (set point over-range) will be displayed when the indication selector switch is depressed to make the check lamp light up. In this case, inside temperature is controlled with temperature setting  $25^{\circ}\text{C}$  ( $77^{\circ}\text{F}$ ) or  $-25^{\circ}\text{C}$  ( $-13^{\circ}\text{F}$ ). When temperature setting is restored to  $-25^{\circ}\text{C} \sim +25^{\circ}\text{C}$  ( $-13^{\circ}\text{F} \sim +77^{\circ}\text{F}$ ), the display becomes normal.

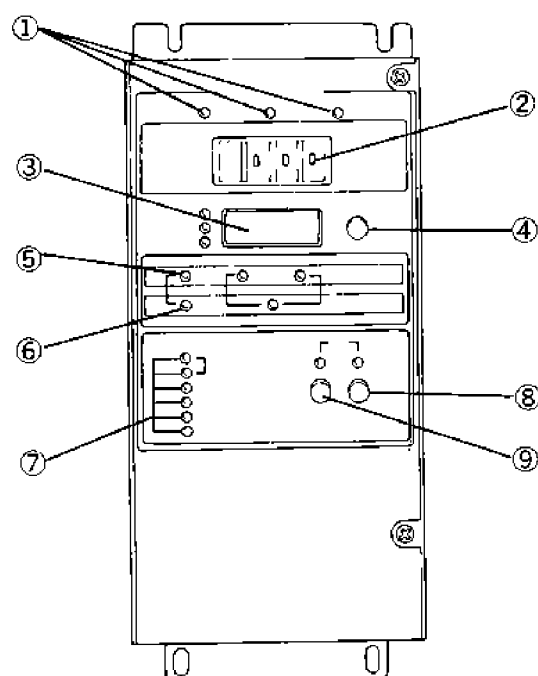

- |                                    |                             |
|------------------------------------|-----------------------------|
| ① Operation display                | ⑥ Control sensor display    |
| ② Set point selector               | ⑦ Output relay displays     |
| ③ Digital display                  | ⑧ Defrost timer test switch |
| ④ IND. selector push-button switch | ⑨ Output relay check switch |
| ⑤ Operation mode display           |                             |

2) Supply and return air temperature

- Depress the indication selector switch so that LED lamp for "SUPPLY" lights up, supply air temperature is displayed, and when the LED lamp for "RETURN" lights up, return air temperature is displayed.

**Note:** When the control sensor is abnormal, "E" is displayed. If the supply sensor (S.S.) is faulty, "E" is displayed together with the lamp for "SUPPLY". When the return sensor (R.S.) is faulty, "E" is also displayed together the lamp for "RETURN". In addition, if the lamp for "CHECK" blinks, depress the indication selector switch to make the lamp for "CHECK" light up, and "E01" or "E02" will be displayed.

3) Confirmation of operation modes

The control sensors of operation modes are switched over automatically depending on temperature setting.

- (a) Above  $-2.9^{\circ}\text{C}$  ( $+26.8^{\circ}\text{F}$ ) (Chilled mode)

- The pilot lamps for CHILLED MODE and SUPPLY SENSOR (Green) light up.

- (b)  $-3 \sim -10^{\circ}\text{C}$  ( $+26.6 \sim +14^{\circ}\text{F}$ ) (Partial frozen mode)

- The pilot lamps for PARTIAL FROZEN MODE and RETURN SENSOR (Orange) light up.

- (c) Below  $-10.1^{\circ}\text{C}$  ( $+13.8^{\circ}\text{F}$ ) (Frozen mode)

- The pilot lamps for FROZEN MODE and RETURN SENSOR (Orange) light up.

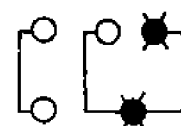
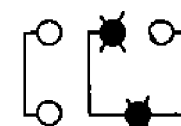
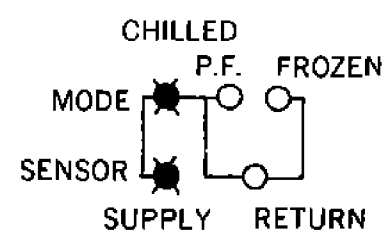

## 4) Function of displays

### (a) Displays for operation states

- COMP (Green).....Compressor in operation
- DEF (Red).....Under defrosting (DFS.ON)
- IN RANGE (Orange).....Suitable temperature (Inside temperature is within temperature setting  $\pm 2^{\circ}\text{C}$  ( $\pm 3.6^{\circ}\text{F}$ ). IRS. ON)

### (b) Displays for output relay operation (Red)

- EVAP.FAN HIGH  
LOW
- EQUALIZE SV
- LIQUID LINE SV1
- DEF.3 WAY SV
- LIQUID LINE SV2

### (c) Displays for alarms

- When the lamp for "CHECK" blinks, depress the indication selector switch to make the lamp for "CHECK" light up, and the followings are displayed in the display window.

PRIORITY NO.	ALARM MESSAGE	MALFUNCTIONS	ACTION
1.	o or A	CPU PCB	●
2.	E.oP	INSUFFICIENT OIL PRESS	●
3.	E.O1	SUPPLY AIR SENSOR	○
4.	E.O2	RETURN AIR SENSOR	○
5.	E.F1	EVAPORATOR FAN MOTOR (MF1-1)	○
6.	F.F2	EVAPORATOR FAN MOTOR (MF1-2)	○
7.	E.O3	DEFROST TERMINATION SENSOR	○
8.	E.Pd	LPS OR SY LEAK FOR PUMP DOWN	○
9.	E.APS	AIR PRESSURE SWITCH (OPTION)	○
10.	E.HdS	MANUAL DEFROST SWITCH	○
11.	E.CLS	OPS RESET SWITCH	○
12.	E.oPS	OPS	○
13.	E.SP	SET POINT SWITCH	●
14.	E.SP <sub>o</sub>	OVER-RANGE OF SET POINT TEMP.	○
15.	E.Ad	ANALOG PCB	●
16.	E.PId	DISPLAY PCB	●
17.	good	NORMAL	

●CHECK OR REPAIR ○IN BACK UP OPERATION

## ●Faulty control sensor (S•S, R•S)

	Normal	SUPPLY SENSOR Abnormal	RETURN SENSOR Abnormal	SUPPLY and RETURN SENSOR Abnormal
CHILLED MODE				
PARTIAL FROZEN MODE				
FROZEN MODE				

## 5) Defrost test

- When the button switch for "DEF. TEST" is depressed, the test lamp (red) lights up and the defrost timer starts counting.
  - Note:** Do not depress the button switch on and off.
- Initiation of defrost (After turning on the button switch)
  - Within In range (IRS.ON) ..Defrost begins after a lapse of 12 seconds (12hr/3600) (DEF lamp lights up)
  - Out of In range (IRS.OFF) ..Defrost begins after a lapse of 4 seconds (4hr/3600) (DEF.lamp lights up)
- The test lamp will go off after counting up of the timer.

### Notes:

1. When temperature of the thermistor for detecting termination of defrost is above  $20^{\circ}\text{C}$  ( $68^{\circ}\text{F}$ ), defrost will not begin even after counting up of the timer. At this time, the test lamp will go off after counting up of the timer.
2. When the test button switch is turned on, the normal timer (4 hours or 12 hours) is cleared up.



## 6) Relay check

Depress the relay check button switch on the controller, and the following operation patterns are performed forcedly for one minute. When the switch is depressed again within one minute, the operation pattern is changed to the next one and continues for one minute. After checking the final operation pattern (C or E), when the switch is depressed within one minute, the normal operation controlled by the thermostat is performed.

In addition, after operating for one minute in test mode, the normal operation controlled by the thermostat is automatically performed. During test operation, the relay check lamp lights up.

MODE	CHILLED PULL DOWN	CHILLED PID	HEAT UP	FROZEN PULL DOWN	FROZEN ON/OFF	
PATTERN	A	B	C	D	E	
SET POINT TEMP.	ABOVE $-10.0^{\circ}\text{C}(+14^{\circ}\text{F})$			BELOW $-10.1^{\circ}\text{C}(+14^{\circ}\text{F})$		
DISPLAY	SUPPLY	$25.0^{\circ}\text{C}$	$0.0^{\circ}\text{C}$	$-10.0^{\circ}\text{C}$	$25.0^{\circ}\text{C}$	$-10.0^{\circ}\text{C}$
	RETURN	$25.0^{\circ}\text{C}$	$0.0^{\circ}\text{C}$	$-10.0^{\circ}\text{C}$	$25.0^{\circ}\text{C}$	$-10.0^{\circ}\text{C}$
	CHECK	a	b	c	d	e
CS	○	○	○	○	×	
EFH	×	○	○	×	×	
EFL	○	×	×	○	○	
LS1	○	○	○	○	×	
LS2	○	○	○	○	○	
ES	○	○	×	×	×	
DS	×	×	×	×	×	
IRS	×	○	×	×	○	
DEF	×	×	×	×	×	
US1	×	○	○	×	×	
US2	×	×	○	×	×	
MV	CLOSED	MODULATED	CLOSED	CLOSED	CLOSED	
RELAY CHECK	LAMP ON					
○ : ON ENERGIZED						
× : OFF DE-ENERGIZED						

### Notes:

1. Check US1 and 2 20MV for their outputs by a tester at the terminal strip of the controller and that in the switch box.
2. Do not check the relays in the following conditions.
  - Under activation of oil pressure switch
  - Under defrosting
  - Under defrosting test

## ③ Function of defrosting

### 1) Initiation of defrosting

- Manual defrost switch (3D)
- Electronic timer
  - Out of In range (Temperature setting  $+2^{\circ}\text{C}$  ( $+3.6^{\circ}\text{F}$ ) or higher).....4 hours
  - Within In range (Temperature setting  $+1^{\circ}\text{C}$  ( $+1.8^{\circ}\text{F}$ ) or lower) .....12 hours

### 2) Termination of defrosting

- Temperature is sensed by the thermistor. (ON point  $+20^{\circ}\text{C}$  ( $+68^{\circ}\text{F}$ )) Defrosting is terminated at over  $35^{\circ}\text{C}$  ( $95^{\circ}\text{F}$ ) ON point  $+20^{\circ}\text{C}$  ( $+68^{\circ}\text{F}$ )

### 3) Back-up function for defrost termination thermistor

- Nearly normal defrosting can be performed when the thermistor is faulty.
- After a lapse of 90 minutes, defrosting will be terminated by the timer.

**Note:** When ambient temperature is below  $-10^{\circ}\text{C}$  ( $+14^{\circ}\text{F}$ ), defrosting is mainly terminated by the timer.

### 4) Function of cold start

- The evaporator fan stops while defrosting. In this regard, after termination of defrosting, if the evaporator fan is operated at once, heated air comes into the storage. In order to prevent hot air from entering, the evaporator fan is delayed in operation by 60 seconds.

### 5) Function of In range masking

- When inside temperature is within the in range . when defrosting begins, the in range lamp lights up forcedly for 90 minutes regardless of inside temperature after that.

### 6) Back-up function for defrosting

- If the contacts of the manual defrost switch (3D) or the air pressure switch (63DA) become faulty (continuously ON), the abnormal displays (E.HdS or E.RP'S) are shown, and at the same time any input is neglected after that. If the unit is restored to normal after termination of next defrosting, it will operate normally.

④ **Back-up function for sensors**

When the control sensors are disconnected or short-circuited, the following functions are performed automatically.

1) Chilled mode

a. Faulty supply sensor (S.S)

This sensor is automatically switched-over to the return sensor (R.S) and return air temperature is controlled higher than temperature setting of the supply sensor by +2°C(+3.6°F).

b. Faulty sensors both for supply and return air temperatures

Forcedly stop the compressor.

2) Partial frozen mode

a. Faulty return sensor (R.S.)

This sensor is automatically switched over to the supply sensor (S.S.) and supply air temperature is controlled lower than temperature setting of the return sensor by -2°C (-3.6°F).

b. Faulty both supply and return sensors.

Forcedly stop the compressor.

3) Frozen mode

a. Faulty return sensor

Forcedly operate the compressor continuously.

⑤ **Back-up function for measuring refrigerant amount (Back-up for solenoid valve)**

During measuring refrigerant amount for defrosting or heat-up operation, if the low pressure switch (63L) will not be turned off within 2 minutes after turning off the solenoid valve (20R1), make "E.P.C" appear in the display window and operate the unit continuously regardless of the signal of the low pressure switch.

⑥ **Function of oil pressure switch**

1) When the contact of the oil pressure switch (63QL) is turned off 110 seconds later after operating the compressor, stop the unit and at the same time make

"E.o.P" appear in the display window together with the lamp for "CHECK".

2) When the reset switch (3QL) is turned on within 120

seconds, the display "E.o.P" blinks, and the unit will operate automatically after a lapse of 120 seconds.

When it is reset after 120 seconds, the unit starts operating at once.

⑦ **Back-up function for fan motor**

1) When the protective devices for the evaporator fan motors are activated, "E-F1" or "E-F2" is displayed together with the lamp for "CHECK".

2) When the protective devices for two evaporator fan motors are activated, stop the unit with the abnormal display.

3) When the protective device for one of the evaporator fans is activated during low-fan speed operation, the other fan motor speed is changed to high to back-up the other fan operation.



<Function pattern>

Outputs	Operation modes	Sensors	-10	-8	-6	-4	-2	Temperature setting °C	2	4	6	8	10	
LSICS	Chilled	Normal (S.S)	← OFF				ON →							
		Abnormal (R.S)	← OFF				ON →							
	Partial frozen	Normal (R.S)	← OFF				ON →							
		Abnormal (S.S)	← OFF				ON →							
	Frozen	Normal (R.S)	← OFF						ON →					
		Abnormal (S.S)	← ON →											
LS2	Chilled, Partial frozen, Frozen	Normal   Control Abnormal   sensor	← ON →											
IRS	Chilled	Normal (S.S)	← OFF				ON				← OFF			
		Abnormal (R.S)	← OFF				ON				← OFF			
	Partial frozen, Frozen	Normal (R.S)	← OFF				ON				← OFF			
		Abnormal (R.S)	← OFF				ON				← OFF			
DSDFS	All operation modes	On during defrosting ON												
EFL	Chilled, Partial frozen (In case of frozen mode, EFL ON)	Normal   Control Abnormal   sensor												
MV (In case of frozen mode, fully closed)	Chilled	Normal (S.S)	Fully closed				Fully open				Fully closed			
		Abnormal (R.S)	Fully closed				Fully open				Fully closed			
	Partial frozen	Normal (R.S)	Fully closed				Fully open				Fully closed			
		Abnormal (S.S)	Fully closed				Fully open				Fully closed			
Selection of operation modes														
ES														
Defrost termination thermistor														

⑧ Printed circuit boards

1) Functions of printed circuit boards

a. CPU printed circuit board (PB0)

- The CPU printed circuit board is composed of CPU, ROM, RAM, display controller, interval timer, input and output controllers.
- All input and output signals are processed

b. Analog printed circuit board (PB1)

- The analog printed circuit board is composed of amplification circuit, faulty element detecting circuit and A/D current converting circuit.
- Temperature input signals from all sensors which are amplified by the amplification circuit are taken as analog signals and converted to digital signals by the A/D current converting printed circuit and transferred to the CPU printed circuit board.
- The values which are set by the digital switch are transferred to the CPU printed circuit board.

c. Power supply and input/output printed circuit board (PB2)

- The power supply and input/output printed circuit board is composed of buffer circuit, phase control circuit and amplification circuit.
- External contact input signal is received by the buffer circuit and is transferred to the CPU printed circuit board.
- Output signal from the CPU printed circuit board is received by the buffer circuit and is transferred to the relay printed circuit board.
- Phase control signal is transferred to the analog printed circuit board and CPU printed circuit board and is amplified in electric force and is impressed to the propotional control valve (20M).
- The printed circuit board is composed of power supply circuit and constant voltage circuit, and supplies power to the electronic circuit.

d. Indication printed circuit board (PB3)

- The indication printed circuit board is composed of light emitting diodes, digital display circuits, diode matrix circuit, operation mode selector and various switches.
- Indication signal from the CPU printed circuit board is received and is displayed by the light emitting diodes and in digits.
- Signals of the switches on the printed circuit board are transferred to the CPU printed circuit board.

e. Relay filter printed circuit board (PB4)

- The output relay is driven by the output signal from the CPU printed circuit board.

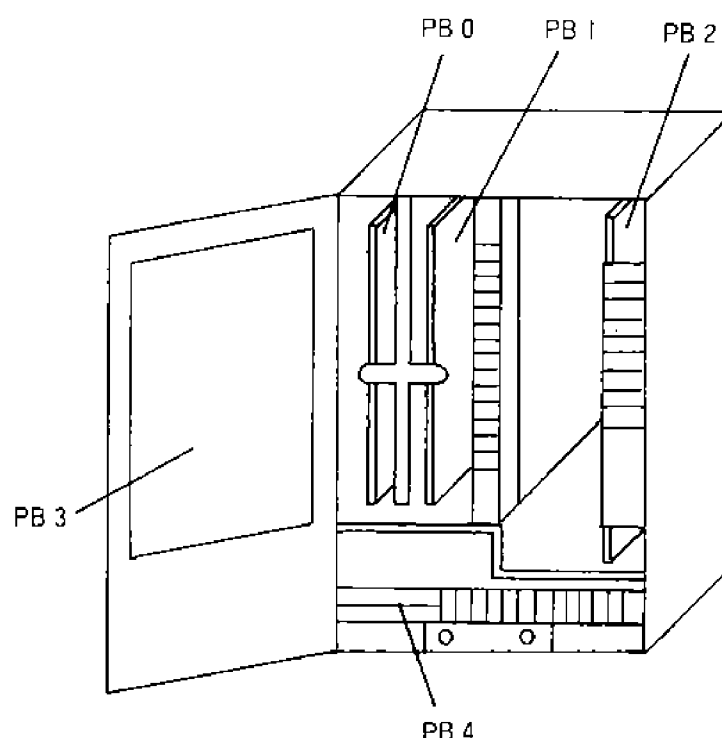

⑨ Operation procedure for emergency

- 1) When the unit cannot be operated due to trouble with the controller, repair it with a spare controller or a circuit board.
- 2) In case spare parts are not obtainable, operate the unit with the following wiring. In this case, however, only forced continuous frozen operation is possible. Temperature control and defrosting cannot be performed.
- 3) Alteration points for wiring

Work: Change wiring on the terminal strip of DECOS to change sequence

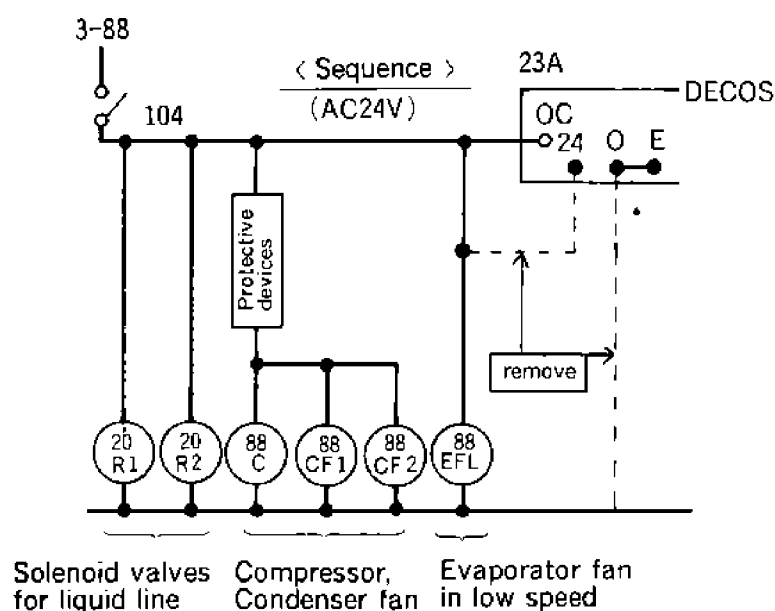

Terminal strip of relay printed circuit board in DECOS

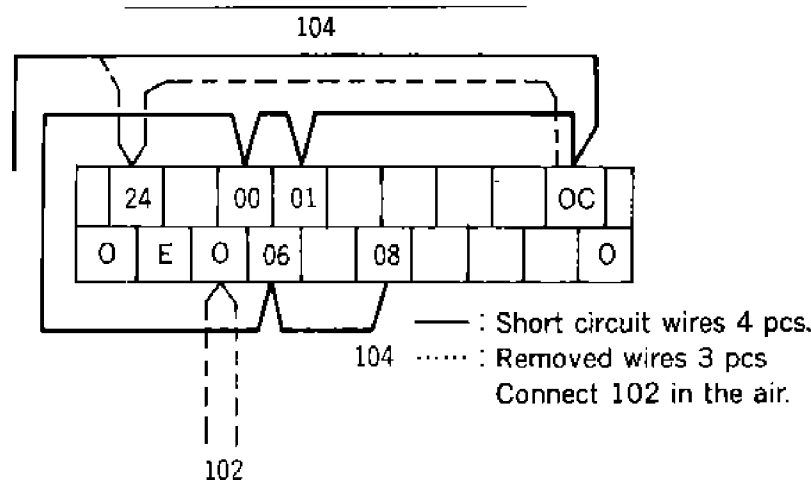

⑩ Sensor characteristics (temperature vs resistance characteristics)

Control sensor (platinum resistance thermometer element) S. S. R. S

Temperature VS resistance characteristics

Rating :  $100\Omega \pm 0.3\%(0^\circ\text{C})$

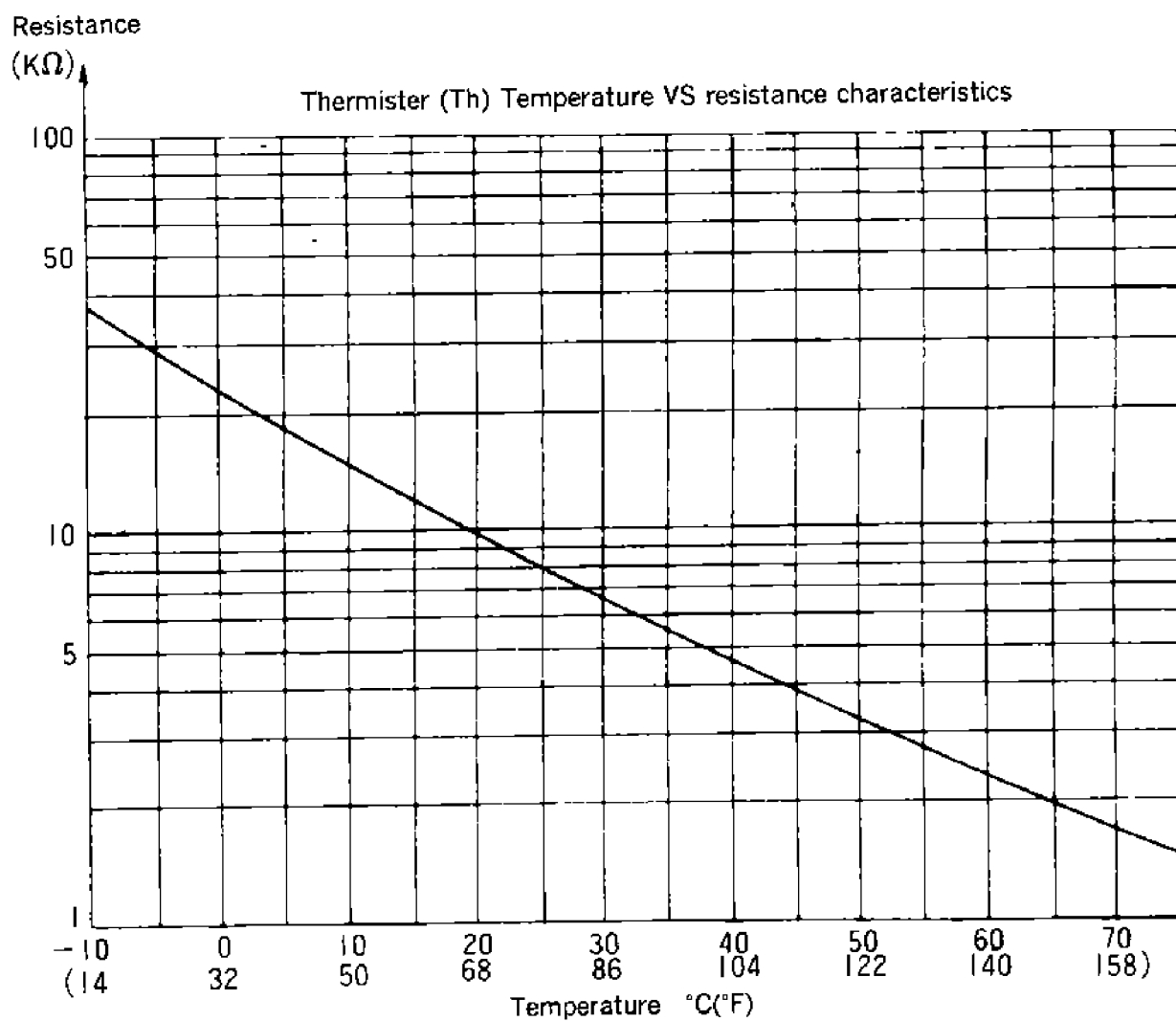
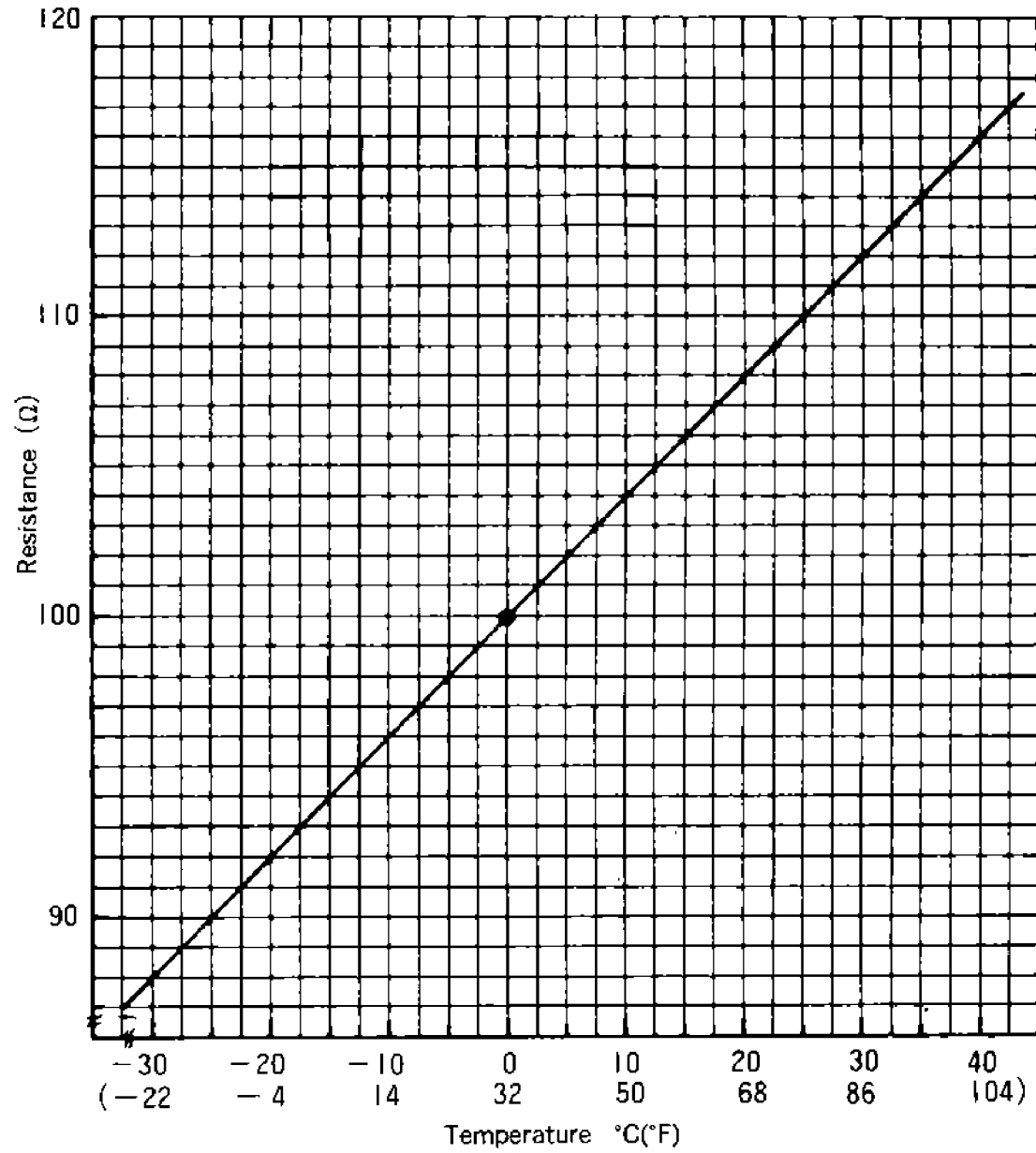



## 6. Maintenance

### 6.1 Handling method of the stop valves

#### (1) Place of the stop valve and its kind

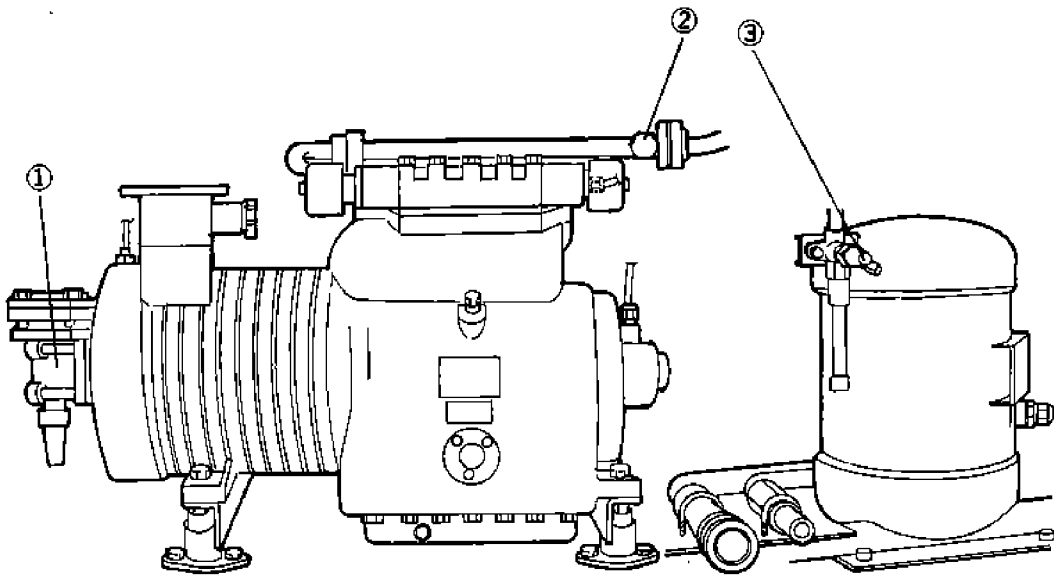

- ① Stop valve at compressor suction side
- ② Stop valve at compressor discharge side
- ③ Stop valve at water cooled condenser (or receiver) outlet side

#### (2) Structure of stop valve

##### 1 Stop valve at compressor suction side (VSH26HL)

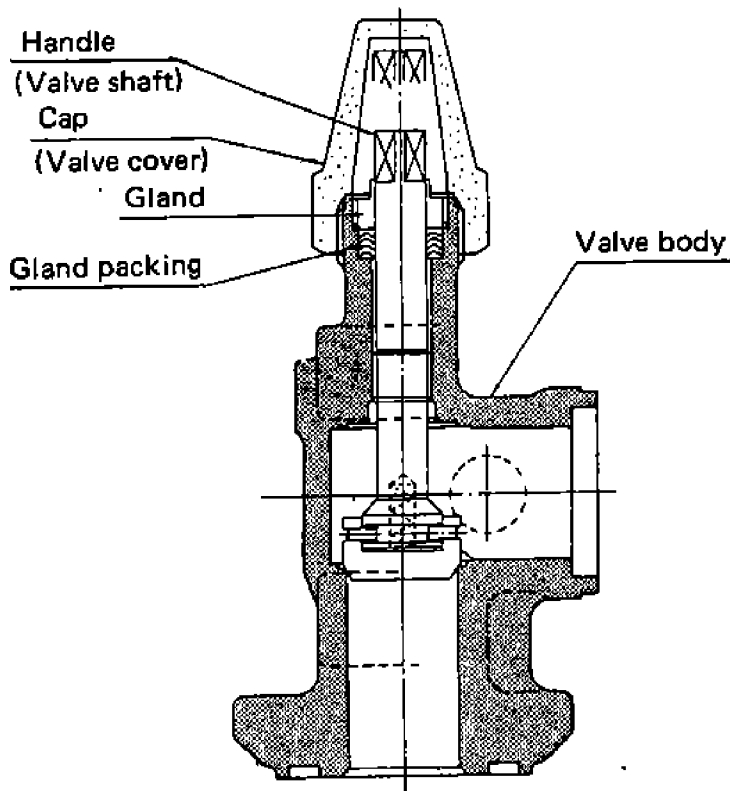

##### 2 Stop valve at compressor discharge side (VSV22CR-7S-7F)

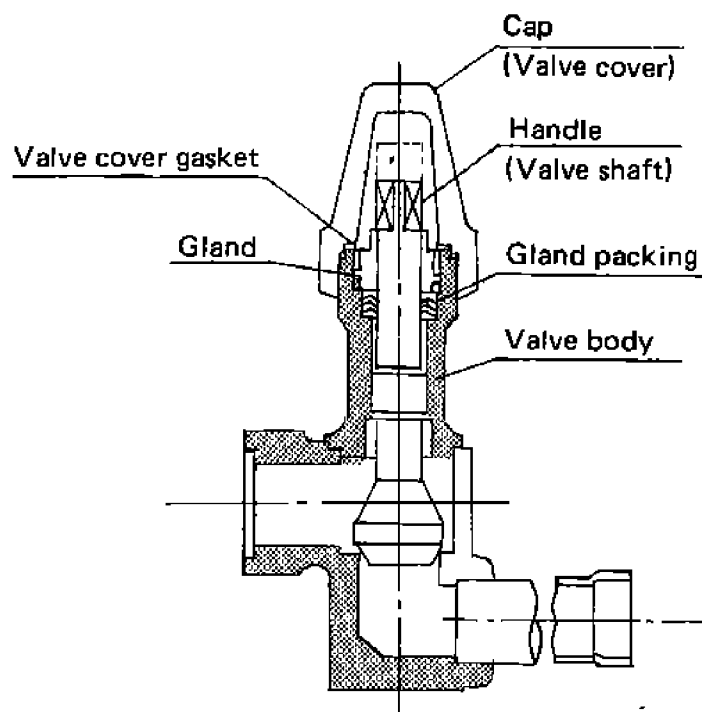

##### 3 Stop valve at water cooled condenser (or receiver) outlet side (VSV10CBP-4S-4SR)

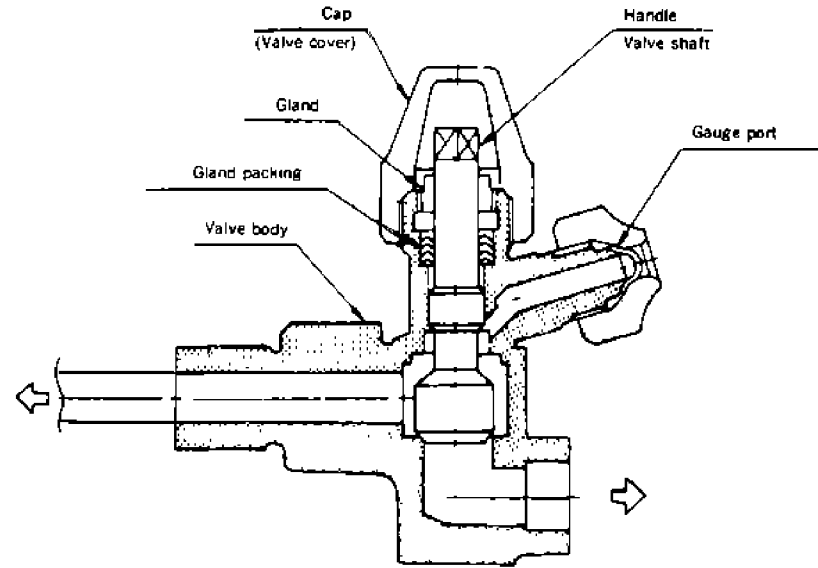

#### (3) Handling method

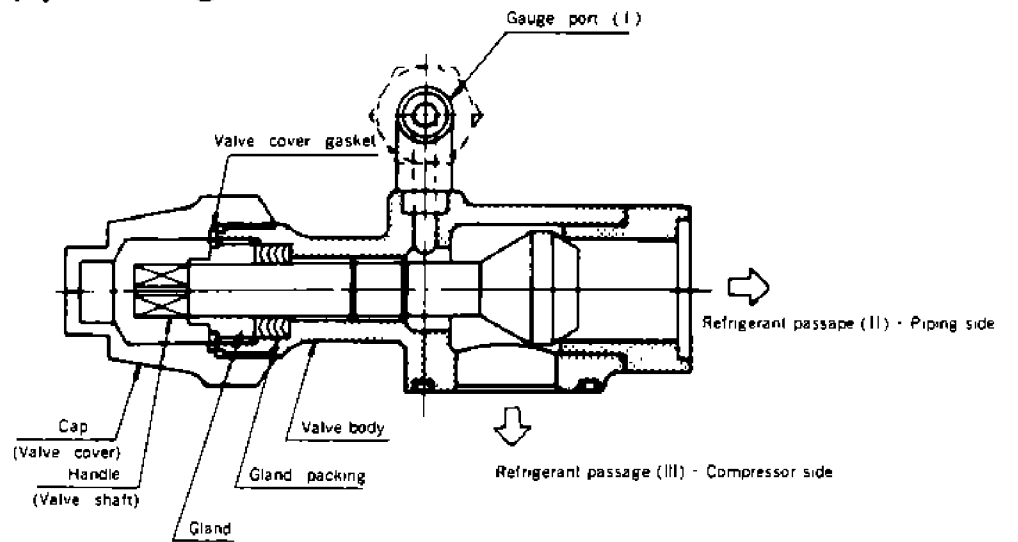

- 1) Remove the valve cap. At this time, be careful not to lose the gasket.
- 2) Loosen the gland in a way the refrigerant is not extracted.
- 3) Fully close the handle .....The refrigerant passage I is connected to III (Front seat)
- 4) Fully release the handle.....The refrigerant passage II is connected to III (Back seat)
- 5) Set the handle at the neutral position .....The refrigerant passage I is connected to II and III.
- 6) The refrigerant passage differs with the procedure mentioned in 3, 4, or 5. So select the best passage by necessity.
- 7) Operate the handle, tighten the gland and place the valve cap as it was after completion of the work. At this time, do not forget to attach the gasket.

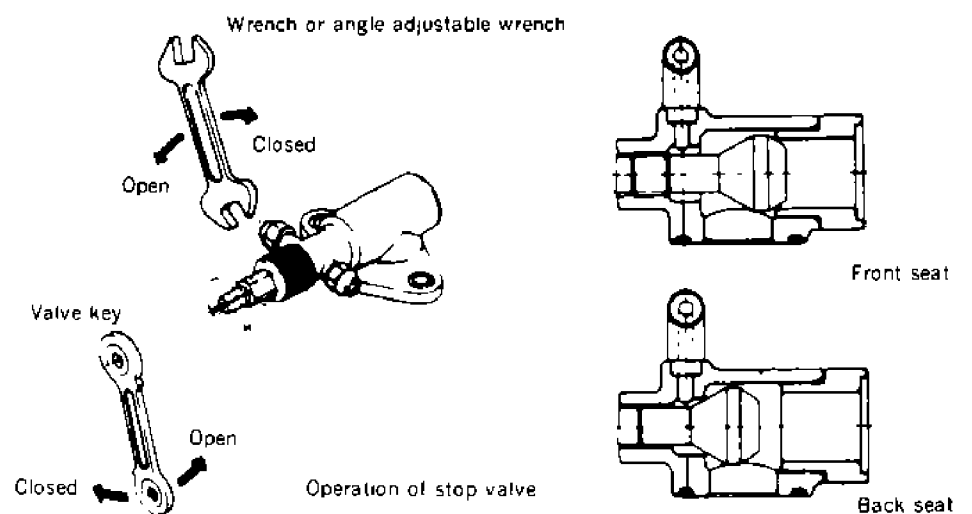

## 6.2 Attaching or removing points of pressure gauges

### (1) Attaching a general pressure gauge

- 1) After closing the stop valve for charging refrigerant fully and opening the stop valve on the outlet of the water cooled condenser (or receiver) fully (back seat), connect the gauge piping to the gauge port.
- 2) Loosen a little the flare nut on the pressure gauge side and turn the handle of the stop valve a little (Middle seat) and return it at once. Thus the air is purged.
- 3) After purging the air, accurately tighten up the flare nut on the pressure gauge side.
- 4) Turn the handle of the stop valve a little, and confirm that the needle of the gauge rises.
- 5) Be certain that the needle of the pressure gauge does not oscillate during the operation of the unit. If it oscillates, do not close the gauge port fully and open the handle of the stop valve a little.
- 6) In case the pressure gauge is attached to the low pressure side, if the low pressure is lower than the atmospheric pressure, the air is drawn in the piping during the air purging. So install the pressure gauge after confirming that low pressure is higher than the atmospheric pressure.
- 7) Operate the unit and confirm that unit is stopped without pump down.

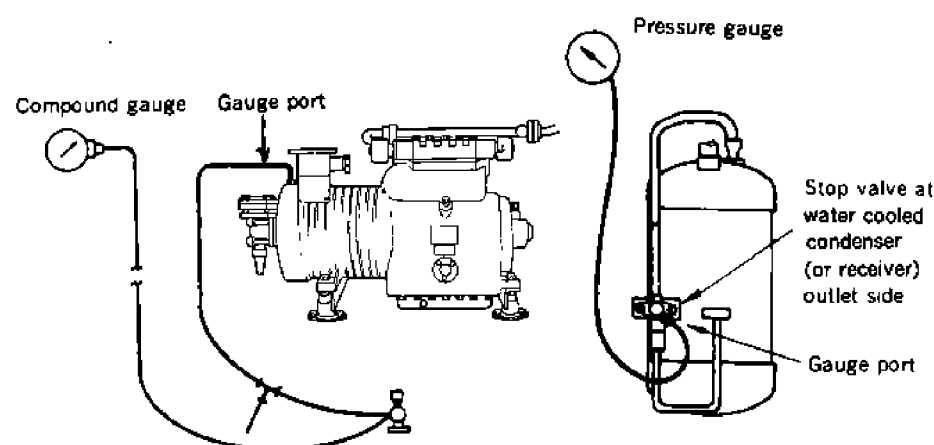

### (2) Attaching the gauge manifold

- 1) With regard to mounting points, note the same caution as that for general pressure gauges.
- 2) Open the cocks which are attached to the both sides of the gauge manifold when mounting. Loosen the blind cover of the centre hose, and close the gauge port for the stop valve for charging refrigerant and the water cooled condenser (or receiver) outlet valve.
- 3) Attach the flare nut of the hose of the manifold on the high pressure side tightly and on the low pressure side loosely.
- 4) Loosen the water cooled condenser (or receiver) outlet valve and vent the air from the hose on the low pressure side and the centre hose and then once again keep the stop valve in the back seat state. After that, tighten up the flare nut on the low pressure side.
- 5) After closing the cocks of the gauge manifold, keep the cock of the stop valve for charging refrigerant and water cooled condenser (or receiver) outlet valve at the neutral seat and measure pressure.

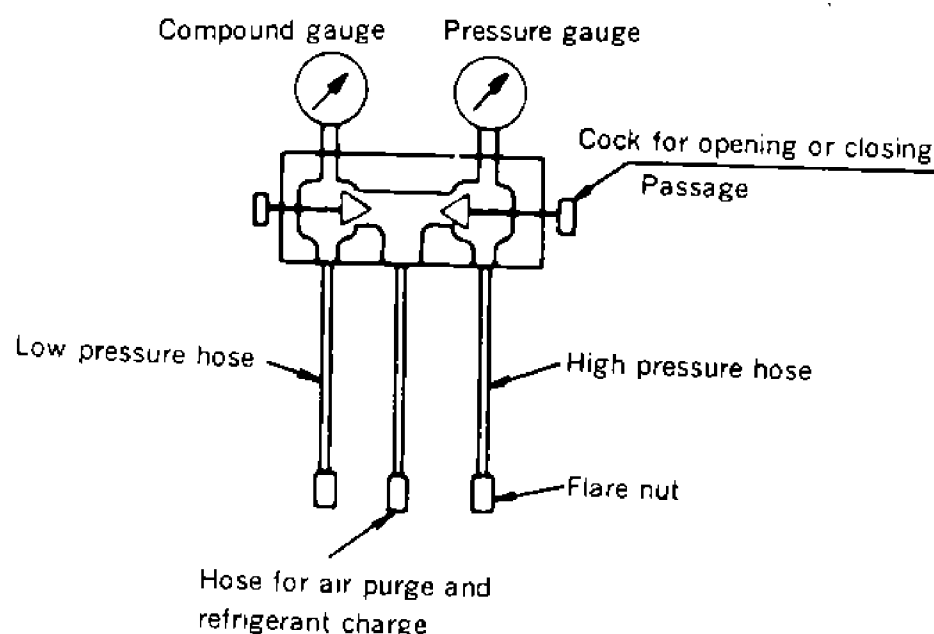

Structure of gauge manifold

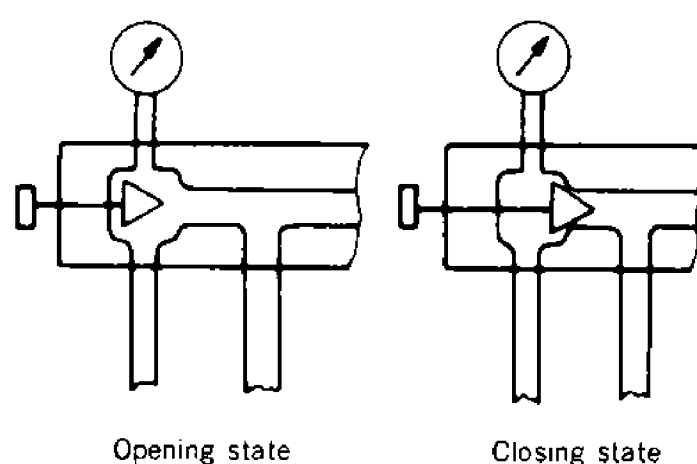

Opening and closing states of gauge manifold

### (3) Removing the pressure gauge and the gauge manifold, as stated below.

When the high pressure hose is removed, note that the liquid refrigerant in the hose may jet out, which is very dangerous.

- 1) Turn the handle of the stop valve, and close the gauge port.
- 2) Open the cock (in case of gauge manifolds) or the flare nuts (in case of general pressure gauges) a little to extract the refrigerant from the hose. At this time, do not open it suddenly so as not to joint out liquid refrigerant.
- 3) After extracting the refrigerant from the hose, remove the pipe connection for the gauge piping.
- 4) Place the blind cover on the gauge port of the stop valve, accurately tighten up the flare nut and confirm no refrigerant leaks.

**Note :** Since the blind cover is very small, be careful not to loose it.

### 6.3 Pump down

Pump down means that the refrigerant in the refrigeration circuit is liquidized and collected in the water cooled condenser (or receiver). This work is required to repair the refrigeration circuit for minimizing leaking volume of the refrigerant and risks due to pressure rising.

<Working procedure>

- 1) Install pressure gauges to the high pressure side the low pressure side.
- 2) Operate the refrigeration unit (either on water cooled or air cooled operation)
- 3) Close the water cooled condenser (or receiver) outlet valve.
- 4) Stop the operation when reading of the low pressure gauge becomes 0.1 kg/cm<sup>2</sup> and close the compressor discharge valve.
- 5) After a short while, read the low pressure gauge. If pressure rises, open the compressor discharge valve and repeat the same procedure.
- 6) Repeat the same procedure two or three times, and the refrigerant is collected in the water cooled condenser (or receiver).

### 6.4 Charging and purging the refrigerant, refrigeration oil

#### (1) Purging non-condensable gas

If non-condensable gas such as air exists in the refrigeration circuit, it is collected by the water cooled condenser (or receiver), which raise pressure in the water cooled condenser (or receiver) abnormally high and reduces heat transferring ratio of the condenser surface. If is, therefore, very important to extract non-condensable gas.

If discharge pressure is abnormally high (even though cooling water volume is increased, in case of water cooled operation) and will not return to the normal pressure, inspect if non-condensable gas such as air exists in the following method.

- Stop the compressor, close the water cooled condenser (or receiver) valve and wait until leaving and entering cooling air (or water) of the air (water) cooled condenser become equal. If there is any difference between saturated pressure corresponding to cooling air (water) and condensing pressure, non-condensable gas exists. In this case, purge non-condensable gas as stated below.
- 1) Accomplish pump down,
  - 2) Condense the refrigerant as much as possible, and then discharge it from the gauge port of the compressor discharge valve.
  - 3) Discharge the condensed refrigerant repeatedly reading the pressure gauge until condensing pressure becomes saturated pressure.

#### (2) Refrigerant purge

There are two methods of refrigerant purge ; i.e. one is for collecting the the refrigerant extracted in a cylinder and the other is for discharging it to the atomosphere.

- (a) Collecting the refrigerant in a cylinder
  - 1) Prepare an empty cylinder which has been dried by forming vacuum inside and weigh it.
  - 2) The cylinder is connected to the gauge port of the water cooled condenser (or receiver) by piping with the cylinder cock closed, and then loosen the flare nut on the cylinder side a little to vent the air from the piping.
  - 3) Operate the refrigeration unit to pump down the refrigerant.
  - 4) After completion of pump down, open the gauge port of the water cooled condenser (or receiver) and then open the cock of the cylinder to collect the liquid refrigerant into the cylinder.
  - 5) After collecting the refrigerant, close the gauge port and the cock and then remove the piping.
  - 6) Be certain that the refrigerant has been collected in the cylinder by weighing it.
  - 7) As for the refrigerant remaining in the refrigeration circuit, extract it to the atmosphere.

- (b) Extracting the refrigerant to the atomosphere

- 1) Open the gauge port of the stop valve for charging refrigerant to extract the gaseous refrigerant to the atmosphere.
- 2) Do not open the compressor discharge valve or the gauge port of the water cooled condenser (or receiver), otherwise the refrigerant oil and the liquid refrigerant are discharged, which may result in shortage of oil or getting chilblains.
- 3) Do not extract the refrigerant in a closed room and also confirm there is no fire around it. Although the refrigerant is non-toxic, there may be fear of suffocation. In addition, if the refrigerant contacts with fire, it yields phosgene gas (toxic gas).

#### (3) Vacuum drying and charging refrigerant and refrigeration oil

If all the refrigerant has leaked out and the air is intermixed in the refrigeration circuit, repair a cause of trouble and do vacuum drying. Then charge the predesigned volume of refrigerant. In case the refrigerant oil is replaced, do the same.

(Required tools)

1. Refrigerant cylinder (20 kg) for R12 (CC12F2) with mouth piece
2. Refrigeration oil (20 ℓ can) SUNISO 3GS-DI
3. φ6.4 CuT (with two flare nuts)
4. Pressure gauge (20 kg/cm<sup>2</sup>), compound gauge (10 kg/cm<sup>2</sup>×75 cmHg) } or gauge manifold
5. Weighing scale (Up to 50 kg)
6. Tools
7. Vacuum pump

- (a) In case the refrigerant is replenished without exchanging the refrigeration oil.
- 1) Connect the vacuum pump to the gauge ports of the stop valve for charging refrigerant and the compressor discharge valves, form vacuum down to 76 cmHg, hold the stop valve in the back seat state and then remove the vacuum pump, leaving the vacuum state in the refrigeration circuit. However, when air enters in the refrigeration circuit, form the vacuum in the circuit down to 76 cmHg and leave it for more than 2 hours (vacuum drying).

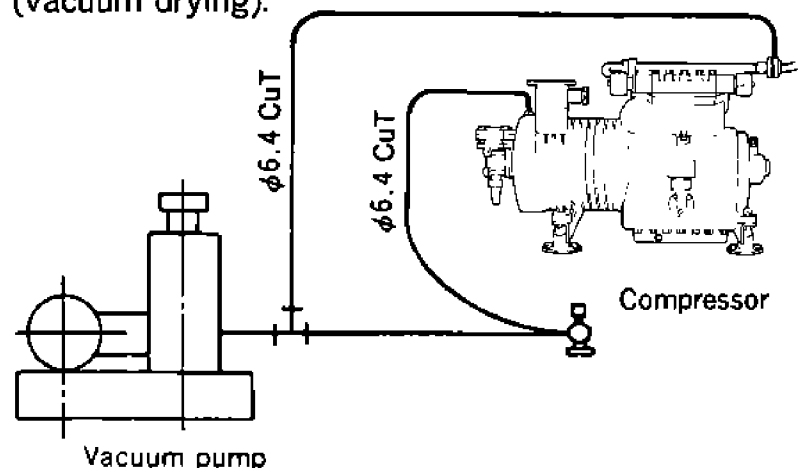

- 2) Place a refrigerant cylinder on the weighting scale, and record its weight.
- 3) In case the refrigerant is charged in the liquid state, do it as shown in the below figure (A). Prevent the liquid refrigerant collected in the water cooled condenser (or receiver) from flowing to the low pressure side. If the refrigerant is hardly charged, operate the compressor to charge it.

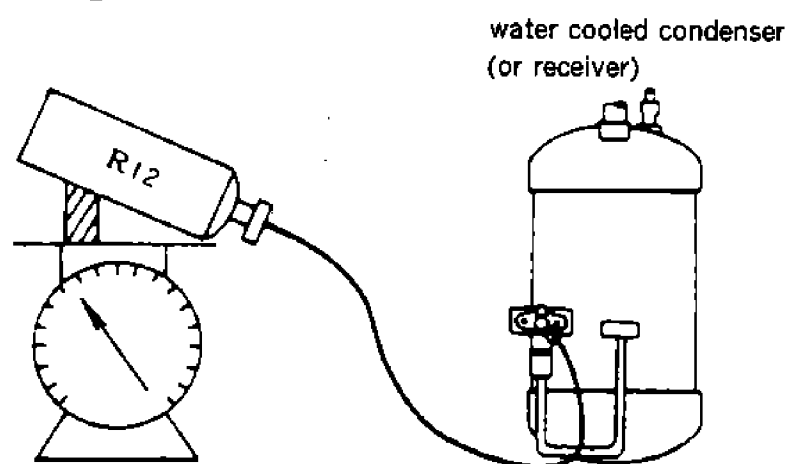

(A) Hold the stop valve in the front seat.

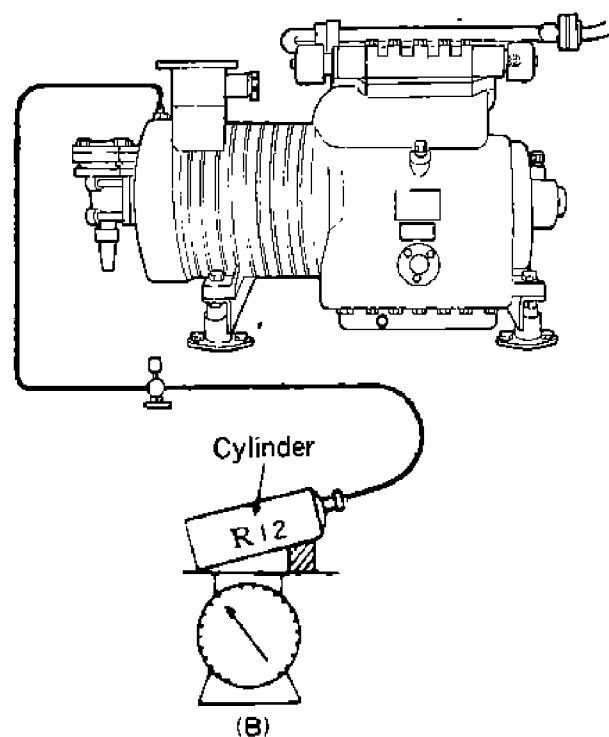

(B)

- 4) In case the refrigerant it charged in the gaseous state, do it as shown in above figure (B). If the refrigerant is hardly charged, operate the compressor to charge it.

- 5) Charge the predesigned volume of the refrigerant in the above stated methods either in 4 or 5.
- 6) After completion of refrigerant charge, hold the stop valve in the back seat state and confirm that if the predesigned volume of the refrigerant has been charged by operating the refrigeration unit.

- (b) Charging the refrigerant as well after replenishment of refrigerant oil

- 1) Extract the refrigerant oil.→Firstly discard all the gas so that pressure in the refrigerant circuit becomes 0. Then loosen the drain plug at the bottom of the compressor to extract all the oil. At this time, firstly open the oil charge plug and then the drain plug to prevent the oil from jetting out.

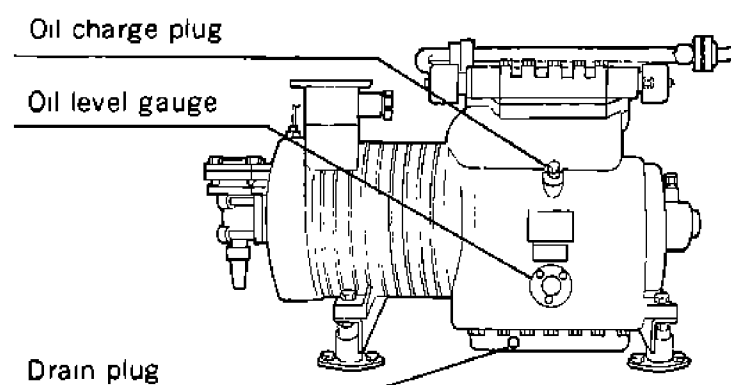

- 2) Tighten up the drain plug.
- 3) Charge the predesigned volume of the oil from the charge plug of the compressor.
- 4) Accomplish vacuum drying and refrigerant charge stated in (1).
- 5) Be sure to stop the compressor while this work is accomplished.
- 6) When the refrigeration oil is discarded, be sure to remove the oil level gauge for cleaning.
- 7) Recommendable refrigeration oil is SUNISO 3GS-DI. SUNISO 3GS—DI is superior to SUNISO 3GS in heat resistance.

Maker of SUNINO 3GS—DI is SUN OIL CO., LTD. (U.S. A.)

- 8) Do not mix two refrigeration oils.
  - 9) Do not use oil which is left opened to the atomosphere for a long time, as it may contain water. In case oil still remains in the oil can after charging, be sure to cap it.
- (c) In case only the refrigeration oil is exchanged.
- 1) Operate the refrigeration unit to pump down the refrigerant by use of the stop valve at the outlet of the water cooled condenser (or receiver) and stop it when low pressure becomes 0.1 kg/cm<sup>2</sup>.
  - 2) Tighten up the discharge valve of the compressor.
  - 3) Open the gauge port on the suction side to extract the refrigerant on the low pressure side.
  - 4) Charge the oil from the oil charge plug. At this time, form the vaccum gradually to hasten oil charge.
  - 5) Restore the stop valve to its original state.



### 6.5 Check points for high pressure switch

Check the high pressure switch for functioning after stopping the condenser fans so as to raise discharge pressure. Remove the lead wire on the strip in the switch box to stop the condenser fans. After finishing the test, provide rewiring accurately as it was.

Air/water cooled type

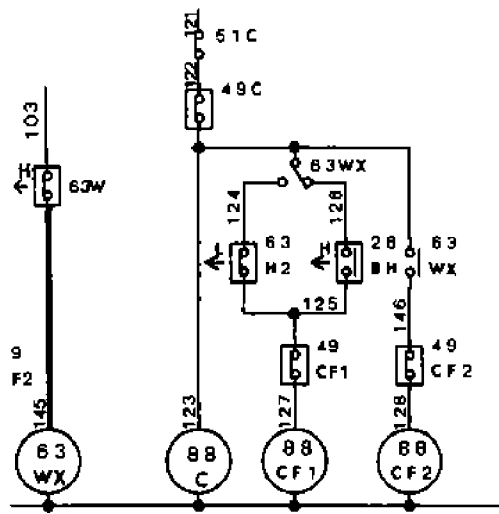

Air cooled type

